



**EPA Certified / Stationary Emergency**

OUTPUT POWER OPTIONS					Natural Gas 125°C STANDBY RATING		LP Vapor 125°C STANDBY RATING		sKVA
Make	Voltage	Alternator	Phase	Hertz	kW/kVA	Amps	kW/kVA	Amps	30% Voltage Dip
Marathon	600	572RSS4270	3	60	425/531	512	300/375	361	1040
	277/480	572RSL4027	3	60	425/531	640	300/375	452	1300
	120/208	572RSL4027	3	60	425/531	1476	300/375	1042	920
	120/240	572RSL4027	3	60	425/531	1280	300/375	903	920
	120/240	572RSL4027	1	60	283/283	1179	283/283	1179	470
Marathon	277/480	572RSL4029	3	60	430/538	647	300/375	452	1500
	120/208	572RSL4029	3	60	430/538	1494	300/375	1042	1050
	120/240	572RSL4029	3	60	430/538	1295	300/375	903	1050
	120/240	572RSL4029	1	60	308/308	1283	294/294	1225	480
Stamford	600	HCI534E17	3	60	425/531	512	300/375	361	1670
	277/480	HCI534E311	3	60	425/531	640	300/375	452	2060
	120/208	HCI534E311	3	60	425/531	1476	300/375	1042	1580
	120/240	HCI534E311	3	60	425/531	1280	300/375	903	1580
	120/240	HCI534E311	1	60	273/273	1138	250/250	1042	1060



**Engine Data**

Manufacturer	Doosan	
Model	21.9L HO	
Aspiration	Turbocharged, Air Cooled	
Arrangement	V-Type, 4-Cycle	
Firing Order	1-12-5-8-3-10-6-7-2-11-4-9	
Displacement: L (in. <sup>3</sup> )	21.9 (1338)	
Bore: mm (in.)	128 (5.04)	
Stroke: mm (in.)	142 (5.59)	
Compression Ratio	10.5:1	
BMEP: psi (kPa)	Natural Gas	213 (1468.6)
	LP Vapor	155 (1068.7)
Gross Horsepower: Natural Gas	649	
	LP Vapor	471
Rated RPM	1800	
Governor	Isochronous	
Speed Regulation	±0.5%	

**Engine Liquid Capacity**

Oil system: qt. (L)	38.5 (36.5)
Cooling System Capacity: gal (L)	50.1 (228)

**Engine Electrical**

Electric Volts: DC	24
Cold Cracking Amps	2200
Battery(s) Required	2

**Fuel System**

Fuel Type	Natural Gas, LP Vapor or Dual Fuel	
Fuel Supply Inlet:		
	Natural Gas	3" NPT
	LP Vapor	3" NPT
Fuel Supply Pressure: in. H <sub>2</sub> O (kPa)		
	Natural Gas	7-11 (1.74-2.74)
	LP Vapor	7-11 (1.74-2.74)

**Filters and Quantity**

Air Cleaner Quantity	1
Oil Filter(s) Quantity	1

**Air Requirements**

Air Filter(s) Type	Dry
Air Flow: CFM (m <sup>3</sup> /min)	40,000 (1133)
Max Air Intake Restriction: in. H <sub>2</sub> O (kPa)	
Clean	5.00 (1.24)
Dirty	15.00 (3.74)
Combustion Air: CFM (m <sup>3</sup> /min)	1027 (29)

**Exhaust System**

Gas Flow: CFM (m <sup>3</sup> /min)	3179 (90)
Max Exhaust Back Pressure: in. H <sub>2</sub> O (kPa)	40.9 (10.2)

**Sound Level**

Open Unit: dBA 3.2 ft (1M)	93.4
----------------------------	------

**Cooling System**

Heat Rejection per CAC: kW (BTUM)	56.7 (3227)
Heat Rejection to Coolant: kW (BTUM)	480 (27,342)
Coolant Flow: gal/min (L/min)	174 (660)

**Fuel Consumption Natural Gas - 130°C**

At 100% of Power Rating: CFH (m <sup>3</sup> /hr)	4,490 (127)
At 75% of Power Rating: CFH (m <sup>3</sup> /hr)	3,500 (99.0)
At 50% of Power Rating: CFH (m <sup>3</sup> /hr)	2,456 (69.54)

**Fuel Consumption LP Vapor - 130°C**

At 100% of Power Rating: CFH (m <sup>3</sup> /hr)	1,495 (42.3)
At 75% of Power Rating: CFH (m <sup>3</sup> /hr)	1,234 (36.0)
At 50% of Power Rating: CFH (m <sup>3</sup> /hr)	849 (24.0)

**GENERAL GUIDELINES FOR DERATION:** Altitude: Derate 0.5% per 100m (328 ft.) Elevation above 1000m (3279 ft.) Temperature: Derate 1.0% per 10°C (18°F) temperature above 25°C (77°F)

**RATINGS:** All three-phase units are rated at 0.8 power factor. All single-phase units are rated at 1.0 power factor.

**125° RATINGS:** 125° apply to installations served by a reliable utility source. The standby rating is applicable to varying loads for the duration of a power outage. There is no overload capability for this rating. Ratings are in accordance with ISO-3046/1, BS 5514, AS 2789, and DIN 6271.

**105° RATINGS:** 105° ratings apply to installations where utility power is unavailable or unreliable. At varying load the number of generator set operating hours is unlimited. A 10% overload capacity is available for one hour in twelve. Ratings are in accordance with ISO-8528/1, overload power in accordance with ISO-3046/1, BS5514, AS2789, and DIN 6271. For limited running time and base load ratings consult the factory. The generator set manufacturer reserves the right to change the design or specifications without notice and without any obligation or liability whatsoever.

## Alternator Data

Manufacturer	Marathon
Type	PMG
Insulation NEMA Rise/Temp	NEMA H/125°C
Hertz	60
Phase	3
RPM	1800
Leads	12
Amortisseur Windings	Full
CFM Cooling Required	1520
Voltage Regulator	DVR2000E+
Sensing	Three Phase
Voltage Regulation, No Load - Full Load	0.25%

## Features

- NEMA MG1-32, BS5000, and IEC 34-1 compliant; CE & CSA Certified and UL Listed
- Self-ventilated and drip proof construction
- Two-thirds pitch stator and skewed rotor
- Wet wound, epoxied field windings
- Designed to withstand overspeeds of up to 125%
- Digital voltage regulator
- Under frequency protection
- Under frequency indication light
- Less than one cycle response time
- Over excitation protection
- Over excitation indication light
- Easy access front-panel adjustments
- Over voltage protection shutdown
- Analog input for paralleling

## Alternator Data

Manufacturer	Stamford
Type	PMG
Insulation NEMA Rise/Temp	NEMA H/125°C
Hertz	60
Phase	3
RPM	1800
Leads	12
Amortisseur Windings	Full
CFM Cooling Required	2780
Voltage Regulator	MX341
Sensing	Single Phase
Voltage Regulation, No Load - Full Load	1.0%

## Features

- BS EN 60034, BS5000, VDE 0530, NEMA MG1-32, IEC34, CSA C22.2-100, and AS1359 complaint
- IP23 enclosure
- Dynamically balanced to exceed BS6861:Part 1 Grade 2.5 vibration standard
- Quality assurance to BS EN ISO 9001
- Self-ventilated and drip proof construction
- Two-thirds pitch stator and skewed rotor
- Heavy duty bearings
- Fully guarded
- Overexcitation protection
- Under frequency protection
- Analog input
- Overvoltage protection
- Paralleling compatible
- Single-phase sensing



## DGC2020 Digital Controller

- Integrated engine-genset control, protection, and metering
- Microprocessor allows for exact measurement, setpoint adjustment, and timing functions
- Front panel 3 position controls and indicators enable quick and simple operation
- Emergency stop push button and an Alarm Horn with silence button
- A wide temperature-range liquid crystal display (LCD) with backlighting
- SAE J1939 Engine ECU communications
- Remote RS-485 communications for Optional RDP-110 Remote Annunciator
- 4 programmable contact inputs and 10 contact outputs (2 ADC rated)
- Modbus Communications with RS-485, Battery Backup for Real Time Clock, UL recognized, CSA certified, CE approved, HALT (Highly Accelerated Life Tests) tested
- IP 54 Front Panel rating with integrated gasket and NFPA 110 Level 1 Compatible.
- Manual Override Keyswitch



## Analog Controller with Emergency Bypass Key Switch

- Automatic CANBUS Engine Control
- Oil Pressure, Water Temperature, Battery Voltage and RPM Gauges
- Automatic Gauge Zeroing on Shutdown
- AC Voltage, Frequency, Percent of Load, and Run-Time Metering
- 3-Position Auto-Off-Manual Control Switch
- LED Status Lights: Low Oil Pressure, High Temperature, Overcrank, Overspeed, & Engine Start



**Standard Features:**

**Warranty**

2 Year Standard
5 Year Comprehensive

- Heavy Duty Steel Base
- Vibration Isolators
- Oil Drain Valve with Extension
- Battery Rack & Cables
- High Ambient Unit Mounted Radiator
- Battery Charging Alternator
- Factory Powder Coating
- Factory Test
- Owner's Manual

**Controller Options**

DGC-2020HD Controller
Fiber Optic Ethernet (DGC-2020HD)
RS-232 Port & Generator Protection (DGC-2020)
Flush or Surface Mount Remote Annunciator
Remote Mount Break Glass E-Stop Switch

**Miscellaneous Options:**

- Battery Charger
- Coolant Drain Kit
- Block Heater
- Line Circuit Breaker
- Pad Type Battery Heater
- Battery Heater Blanket w/Thermostat
- Oil Pan Heater
- Generator Strip Heater

**Narrow Skid Base Open Unit**

**Options:**

- Radiator Duct Flange
- Flex Exhaust
- Critical Silencer
- Wide Skid Base

OVERALL SIZE: 140"L x 90"W x 95"H  
 Approximate Weight: 11,400 lbs.

*Note: Dimensions and weights reflect standard open unit with no options and are subject to change.*

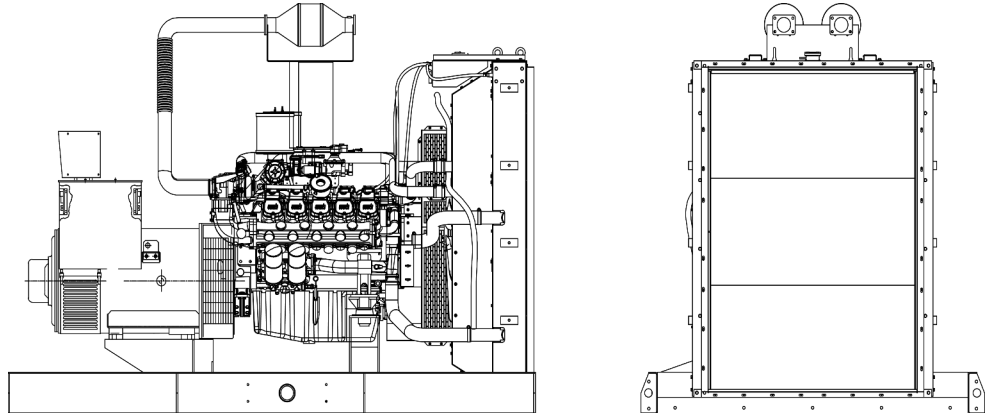

**Standard Enclosed Unit**

**Options:**

- Sound Attenuated Enclosure
- Load Center, Lights & GFI Receptacle

OVERALL SIZE: 186"L x 90"W x 106"H  
 Approximate Weight: 13,100 lbs.

*Note: Dimensions and weights reflect standard enclosed unit with no options and are subject to change.*

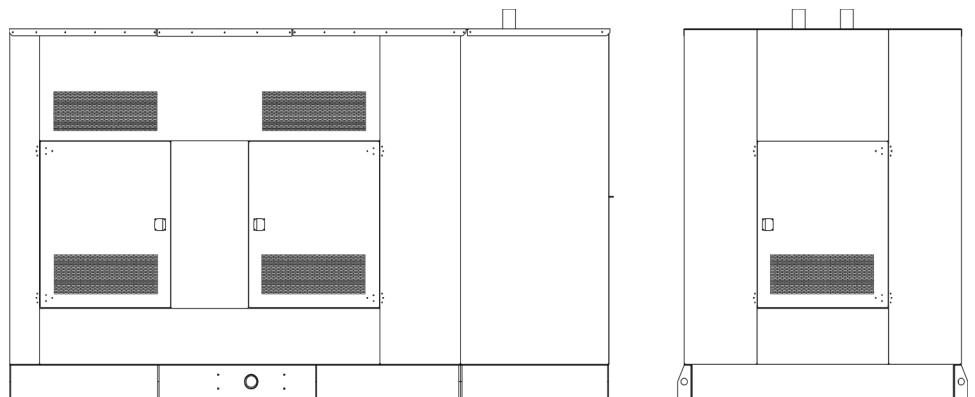

**Note: The above drawings are provided for reference only and should not be used for planning installation. Contact your local distributor for more information.**