

Features

PSI 8.8L Engine

The 8 cylinder, overhead valve engine meets EPA/CARB standby emission regulations.

Stamford Generator End

Industrial grade generator ends.

Adjustable Circuit Breaker

Adjustable trip point make field reconnects simple.

Battery Charger

Factory installed 3 stage, 2 Amp battery charger.

Block Heater

In-line Kim Hotstart, 120V, block heater with thermostat.

DSE 8610 MKII

Our digital controller is powerful and dynamic with a user-friendly interface and allows up thirty-two PSS150s operating in parallel.

Galvanealed Steel Weather Enclosure

Our weather enclosures provide sound reduction while our powder coat paint provides a durable, long lasting finish.

100% Load Tested

You won't find statistical sampling here. We load test every generator before it leaves our facility.

PACKAGED STANDBY SYSTEMS

250,000 Running Watts-LP

300,000 Running Watts-NG



Optional Accessories

Generator Strip Heater

Reduces condensation.

ASCO Automatic Transfer Switch

Safely restore power to critical circuits.

Vapor Fuel Strainer

Keep the fuel line free from debris that could cause damage to you generator.

Battery Charger Upgrade

Upgrade from the standard 2 Amp charger to a 5 Amp or 10 Amp with fail contact or 10 Amp NFPA compliant.

DSE8660

Allows advanced paralleling and load control options. Installed as a separate control module outside of the generator sets.

Battery Heater

Keeps battery warm for maximum power output at start-up.

NFPA 110 Level 1

Factory installed, includes remote annunciator, DSE 10 Amp battery charger, and low coolant alarm. This system will have the capability to start and accept load in 45 seconds.

WebNet

Control your generator from your smartphone or computer.

LP Liquid Withdrawal

Pulls liquid LP from tank and vaporizes on eng/gen set; allowing you to install smaller fuel lines and smaller fuel tanks.

| MODEL NUMBER | OUTPUT | LP GAS | | | NATURAL GAS | | |
|--------------|--------------|---------|-------|-----|-------------|-------|-------|
| | | VOLTS | WATTS | KVA | AMPS | WATTS | KVA |
| PSS300-4 | 120/208 3-PH | 250,000 | 312 | 868 | 300,000 | 375 | 1,041 |
| PSS300-17 | 120/240 3-PH | 250,000 | 312 | 750 | 300,000 | 375 | 900 |
| PSS300-18 | 277/480 3-PH | 250,000 | 312 | 375 | 300,000 | 375 | 451 |

Derating factors: **Temperature** - 3% for every 10°F above 77°F air inlet **Elevation** - 3% per 1,000 feet elevation above sea level.

GENERATOR

| | |
|-----------------------------------|-------------------------|
| 3 PHASE ⁽¹⁾ | 12 LEAD |
| VOLTAGE REGULATION | +/- 1% |
| VOLTAGE CONTROL | AS440 |
| TOTAL HARMONIC DISTORTION | < 5% |
| TEMPERATURE RISE | 125°/40° C |
| TYPE | 4 POLE ROTATING FIELD |
| BRUSHLESS | YES |
| GENERATOR SPEED | 1800 RPM |
| ROTOR | 2/3 PITCH |
| WINDINGS | 100% COPPER |
| STATOR WINDING | DOUBLE LAYER CONCENTRIC |
| EFFICIENCY PEAK | 92.5% |
| COUPLING | FLEXIBLE DISC |
| BEARINGS | (1) MAINTENANCE FREE |
| TELEPHONE INTERFERENCE | < 2% |
| INSULATION | CLASS H |
| GENERATOR WARRANTY ⁽²⁾ | 2 YR/2000 HRS |

NOTES: (1) 3-PH power factor 0.8 (2) For generator warranty information contact your local WINCO service center.

GENSET

| | |
|--|----------------|
| CIRCUIT BREAKER ⁽¹⁾ | ADJUSTABLE |
| MOTOR STARTING (GODE G) ⁽²⁾ | |
| NG | 150 HP |
| LP | 200 HP |
| CARB/EPA APPROVED | YES |
| CSA APPROVED | YES |
| UL2200 LISTED | YES |
| TOGGLE FUEL SELECTOR | STANDARD |
| WINCO WARRANTY ⁽³⁾ | 2 YRS/2000 HRS |

NOTES: (1) When voltage connection is changed, the Instant Trip switch must be changed. See generator manual for complete details. (2) Code G capacitor motor. (3) For generator warranty information contact your local WINCO service center.

ENGINE

| | |
|--------------------------------|--------------------------|
| BRAND | PSI |
| MODEL | 8.8 INDUSTRIAL |
| SPEED | 1800 RPM |
| DISPLACEMENT | 8.8L |
| CYLINDERS | 8 |
| LUBRICATION | FORCED W/ SPIN-ON FILTER |
| COOLING | LIQUID |
| BORE X STROKE | 4.35 X 4.50 |
| IGNITION | ELECTRIC |
| GOVERNOR | ELECTRONIC |
| EXHAUST | CRITICAL GRADE |
| EXHAUST OUTLET SIZE | 5" AT MUFFLER |
| RECOMMENDED OIL | SAE 10W-30 |
| OIL CAPACITY | 2.25 GALLONS |
| LOW OIL PROTECTION | STANDARD |
| HIGH COOLANT TEMP PROTECTION | STANDARD |
| ENGINE WARRANTY ⁽¹⁾ | 3 YRS/3500 HRS |

NOTES: (1) Contact your local PSI service center for engine warranty information.

FUEL - PER UNIT

| | |
|------------------|---|
| FUEL CONSUMPTION | |
| LP @ 100% LOAD | 713 FT ³ /HR - 1,832,410 BTU/HR |
| NG @ 100% LOAD | 1965 FT ³ /HR - 2,004,300 BTU/HR |
| INLET PRESSURE | 4-6 OZ / 7"-11" WATER COLUMN |
| FUEL INLET SIZE | 1.25" |

FUEL - WHOLE SYSTEM

| | |
|------------------|---|
| FUEL CONSUMPTION | |
| LP @ 100% LOAD | 1426FT ³ /HR - 3,664,820 BTU/HR |
| NG @ 100% LOAD | 3930 FT ³ /HR - 4,008,600 BTU/HR |

BATTERY - PER UNIT⁽¹⁾

| | |
|--------------------|---------------------|
| DC SYSTEM VOLTAGE | 12V |
| DC ALTERNATOR | ENGINE MOUNTED |
| BATTER RACK/ CABLE | INCLUDED |
| BATTERY CHARGER | 2A STAGE 3 INCLUDED |
| REQUIRED BATTERY | BCI 31 900 CCA |

NOTES: (1) Battery not included

DSE 8610 MKII CONTROL FEATURES

| ENGINE DISPLAY/PROTECTION | |
|---------------------------|----------|
| ENGINE RPM | YES |
| LOW OIL PRESSURE | YES |
| HIGH COOLANT TEMPERATURE | YES |
| LOW COOLANT LEVEL | OPTIONAL |
| OVERSPEED | YES |
| UNDERSPEED | YES |
| OVERCRANK | YES |
| CAN ECU SHUTDOWN | YES |
| GENSET DISPLAY/PROTECTION | |
| SYNCHRONIZATION CONTACTOR | YES |
| VOLTAGE (L-N) | YES |
| VOLTAGE (L-L) | YES |
| OVER VOLTAGE | YES |
| UNDER VOLTAGE | YES |
| OVER FREQUENCY | YES |
| UNDER FREQUENCY | YES |
| LOADING FREQUENCY | YES |
| OVER CURRENT | YES |
| SHORT CIRCUIT | YES |
| KW, KVA, KVARH DISPLAY | YES |
| KWH, KVAH, KVARH DISPLAY | YES |
| EARTH FAULT | OPTIONAL |
| OVERLOAD PROTECTION | YES |

DBA @ 7 METERS

| | |
|-----------|------|
| NO LOAD | 77.6 |
| FULL LOAD | 80.8 |

SHIPPING - PER UNIT

| | |
|--------------------------------|-----------------------|
| DIMENSIONS - ENCLOSED (LxWxH) | 132" x 52.75" x 72.2" |
| DIMENSIONS - OPEN SKID (LxWxH) | 117" x 52.75" x 72.1" |
| NET WEIGHT | 4,700 LBS |
| SHIP WEIGHT | 4,720 LBS |
| FREIGHT CLASS | 70 |

ADDITIONAL DISPLAYS/PROTECTIONS

| | |
|----------------------------|----------|
| EMERGENCY STOP | YES |
| BATTERY VOLTAGE | YES |
| BATTERY OVER/UNDER VOLTAGE | YES |
| BATTERY CHARGER FAILURE | OPTIONAL |
| MAINS DECOUPLING | YES |
| FAIL TO SYNC ALARM | YES |
| R.O.C.O.F. ALARM | YES |
| VECTOR SHIFT ALARM | YES |
| VOLTAGE ALARM | YES |
| FREQUENCY ALARM | YES |

COMMUNICATIONS

| | |
|---------------------------|----------|
| USB CONNECTABLE | YES |
| RS232/RS485 | YES |
| NFPA ANNUNCIATOR OPTIONAL | DSE 2548 |
| REMOTE DISPLAY PANEL | OPTIONAL |
| ETHERNET/MODEM | OPTIONAL |
| MSC LINK | YES |

ADDITIONAL FEATURES

| | |
|-------------------------------|--------------------|
| AUDIBLE ALARM | YES |
| ENGINE EXERCISER | USER ENABLED |
| MAINTENANCE INTERVAL TIMER | USER ENABLED |
| CONFIGURABLE INPUTS OPTIONAL | 12-32 W/4 DSE 2130 |
| CONFIGURABLE OUTPUTS OPTIONAL | 8-80 W/DSE 2157 |
| EVENT LOG | 250 |
| ALTERNATIVE CONFIGURATIONS | 3 |
| UL/CSA LISTED | YES |
| SYNCHRONIZE SET CAPABILITY | 32 |
| DEAD BUS SENSING | YES |
| HEATED DISPLAY | YES |

Contact your local WINCO dealer for more DSE8610 MKII information.

ENCLOSED

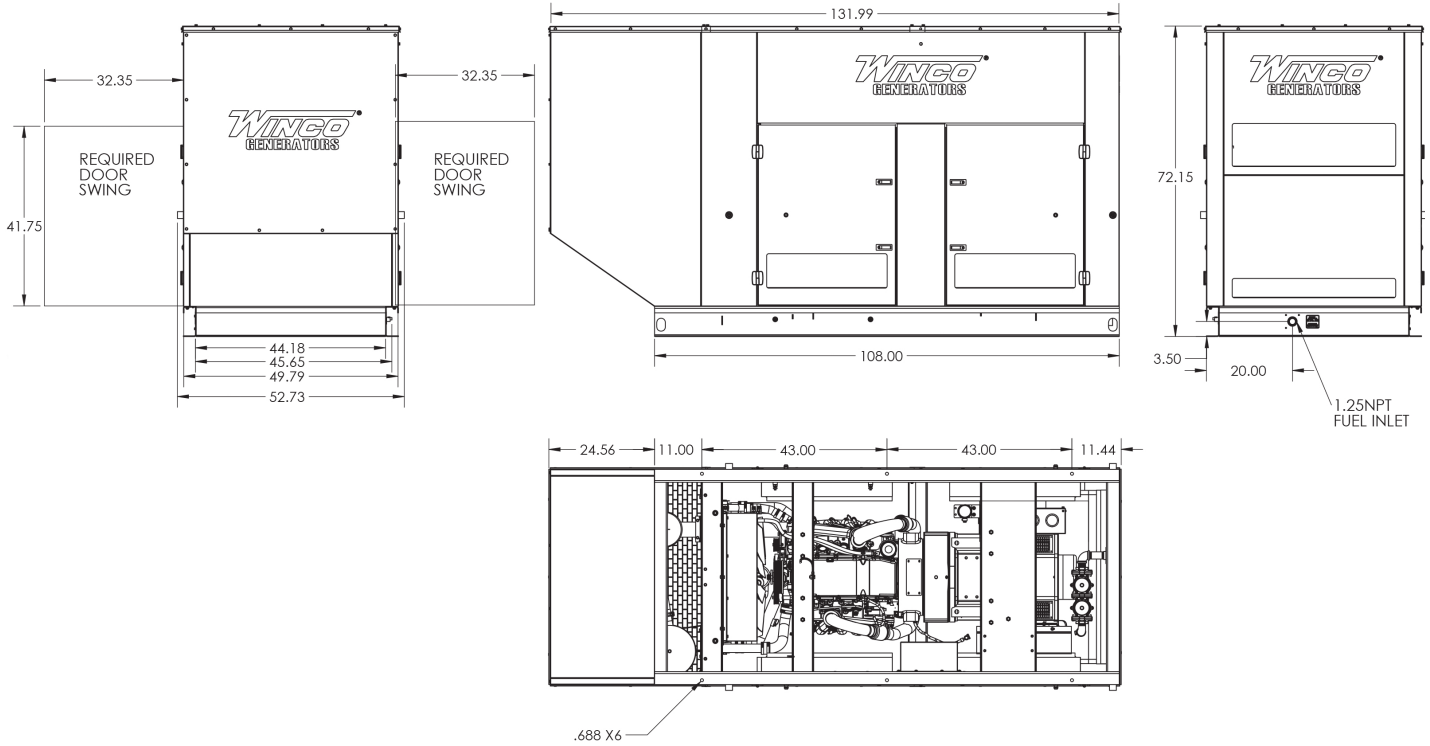

OPEN SKID

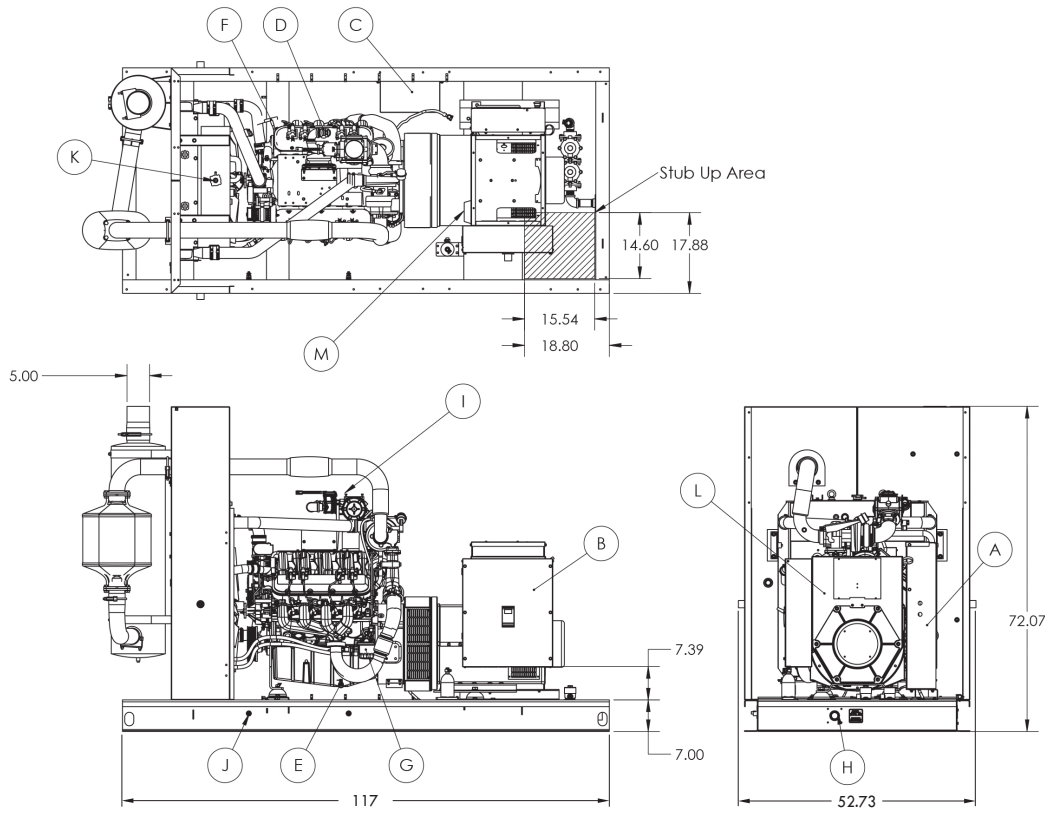

| KEY COMPONENTS | |
|----------------|--------------------------------|
| A | ENGINE CONTROL |
| B | MAIN LINE CIRCUIT BREAKER |
| C | GROUP 24 BATTERY(NOT INCLUDED) |
| D | OIL FILL |
| E | OIL DRAIN |
| F | OIL DIPSTICK |
| G | OIL FILTER |
| H | FUEL INLET |
| I | AIR FILTER |
| J | COOLANT DRAIN |
| K | COOLANT FILL |
| L | AVR |
| M | BATTERY CHARGER |

Specifications are subject to change without notice.