

TECHNICAL MANUAL

WT3000-iR-AG

Weighing Indicator

Portable. Connected. **Farm-Ready.**



WT3000-iR-AG Weighing Indicator — Technical Manual

Operation, configuration, calibration, communication and connection reference for the WeightechUSA WT3000-iR-AG weighing indicator.

- IP68
- 6-DIGIT LCD
- RS-232
- RS-485
- BLUETOOTH
- 8 × 350 Ω

Thank you for choosing WeightechUSA.

Beyond acquiring excellent-quality equipment, you can count on an agile, responsive support team to resolve any issue that arises while you use your new indicator.

Before using your WeightechUSA WT3000-iR-AG weighing indicator for the first time, read this manual carefully. You can find more information about this and the rest of the catalogue at weightechusa.com.

Published by WeightechUSA · WT3000-iR-AG Technical Manual · Technical manager: Eng. Alexandre Kremer. See *Weightech addresses* for office locations.

Contents

1	Technical characteristics
2	General recommendations
3	External appearance
4	Connections
5	Key functions
6	Operation
7	User settings
8	Transmission-format details
9	Calibration parameters
10	Detailed connections
11	Self-test screens
12	Error messages
13	Appendix
14	Weightech addresses

1 Technical characteristics

Characteristic	Unit	Value
Sensitivity	μV/d	0.3
Measuring range	mV/V	from -1 to +14
Zero-signal balancing range	mV/V	from -1 to +5
Units of measure		kg, g
Internal resolution		1 / 500,000
Non-linearity		0.01% FS
Max. number of load cells		8 × 350 Ω
Load-cell excitation voltage	VDC	5
Load-cell connection		6-wire
Power supply	VAC	External source, AC input 110 or 220 V 50/60 Hz, output 12 V/1 A / Internal rechargeable battery 6 V / 4.5 Ah
Maximum consumption	mA	150
Operating temperature range	°C	0 to +40
Display	mm	LCD, 6 digits, with backlight
Display digit height	mm	55
Display legends		Zero, Net, Battery level, Stability, Gross, Bluetooth communication active, Low, High and OK.
Communication interfaces		RS232 serial output and Bluetooth, or RS485
Protection rating		IP68

2 General recommendations

- ✓ The indicator must not be exposed directly to intense sunlight.
 - ✓ The indicator must be used on a flat, well-levelled surface.
 - ✓ The electrical mains supply must be earthed (grounded).
 - ✓ This equipment cannot be used in an area classified as having an explosion risk.
 - ✓ Do not clean the indicator with corrosive products.
 - ✓ Switch the indicator off when connecting it to other devices, including the load cell.
 - ✓ If the equipment is not used for prolonged periods, it is recommended that the battery installed inside the equipment be recharged every 3 months in order to prevent damage.
-

3 External appearance



WT3000-iR-AG in its rugged, sealed carrying case.

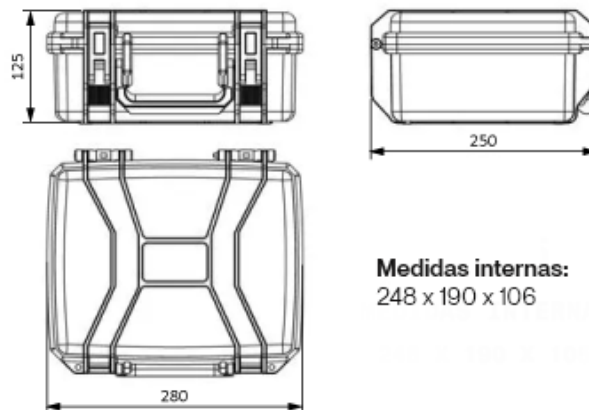

Case dimensions (mm). Internal dimensions: 248 × 190 × 106 mm.

4 Connections









Indicator connections — overview.





Connection and calibration-switch detail on the main board.

5 Key functions

Key	Function
	Turns the equipment on or off. <i>Note: to turn it off, press for approximately 2 seconds.</i>
	Key with the function specified in parameter FnC 12, used to activate the pre-tare or to start a new weighing.
	Switches the display between gross-weight and net-weight values. (◀ <i>Left</i>)
	Switches the weighing mode of the device. (▼ <i>Down</i>)
	Zeroes the scale when the empty platform does not read zero. (▲ <i>Up</i>)
	Deducts the tare value. (▶ <i>Right</i>)
	Accumulates the weight shown on the display and sends it for printing, according to the initial configuration.

6 Operation

 To turn the indicator on, press the  key. On power-up, the display runs the self-test, counting from “999999” down to “000000”. It then enters weighing mode.

To turn the indicator off, hold the  key pressed for about 2 seconds.

6.1 Charging the battery

To charge the battery, connect the indicator to the electrical mains, checking the indicator’s supply voltage value via the external power source (110 V or 220 V).

Current-consumption table according to the indicator configuration:

Configuration	Consumption
1 load cell	125 mA
1 load cell with display backlight on	159 mA
4 load cells	171 mA
4 load cells with display backlight on	194 mA
4 load cells and TCP/IP board	288 mA
4 load cells with display backlight on and TCP/IP board	314 mA

INFORMATION ABOUT 6 V 4.5 AH LEAD-ACID BATTERIES

Specification	Value
Nominal voltage	6 V
Nominal capacity	4.5 Ah
Dimensions (Length × Height × Width)	70 × 47 × 100 (mm)
Weight	0.81 kg
Maximum discharge current	67.5 A (5 s)
Internal resistance	Approx. 25 mΩ

Specification	Value
Operating temperature range	Discharge: 15 to 50 °C · Charge: 0 to 40 °C
Ideal operating temperature	25 ± 3 °C

The Lead-Acid batteries used in our weighing equipment have characteristics that make estimating their service life completely variable. The discharge duration, for example, is affected in several ways — by the current drawn by the load, the temperature at which the battery is operating, its nominal charge at the start of discharge, among others. This section aims to clarify some points so that it is possible to understand how to extend the service life and the time between battery replacements in our weighing equipment.

Float Charging Characteristics

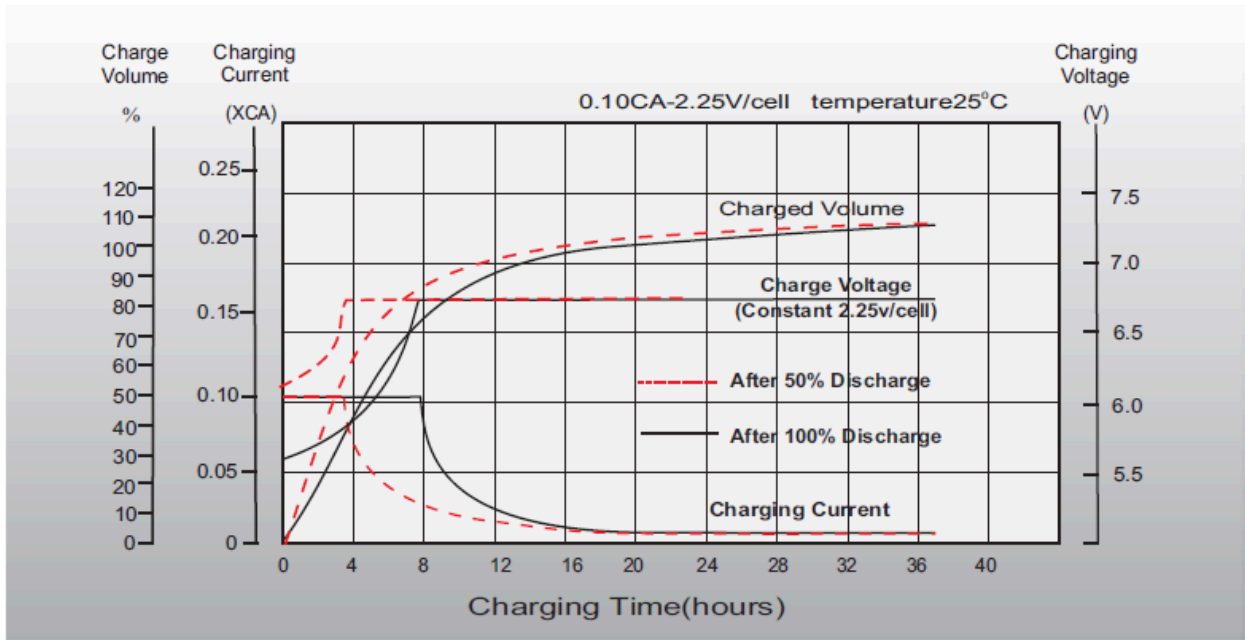

Battery charging characteristic: charge current behaviour versus the supplied charging voltage and versus charging time, for a fully-discharged battery and for one at 50% charge.

The chart above illustrates the battery-charge information and how the current draw behaves with respect to the charging supply voltage and also with respect to charging time. Note that the behaviours differ for the charging process depending on the discharge state the battery is in (fully discharged, or with 50% charge available in this chart).

In these cases it is always recommended to avoid the battery being completely discharged before arranging a new charge. For example, considering a charging time of 8 h: if the battery is 100% discharged, after this time it will reach only about 70% of its nominal capacity, whereas with a battery still at 50% charge, when charging begins we will reach about 90% of the nominal capacity within these same 8 hours.

The ideal battery charging time according to the chart, in order to reach 100% of its nominal capacity, is 24 uninterrupted hours.

Discharge Characteristics

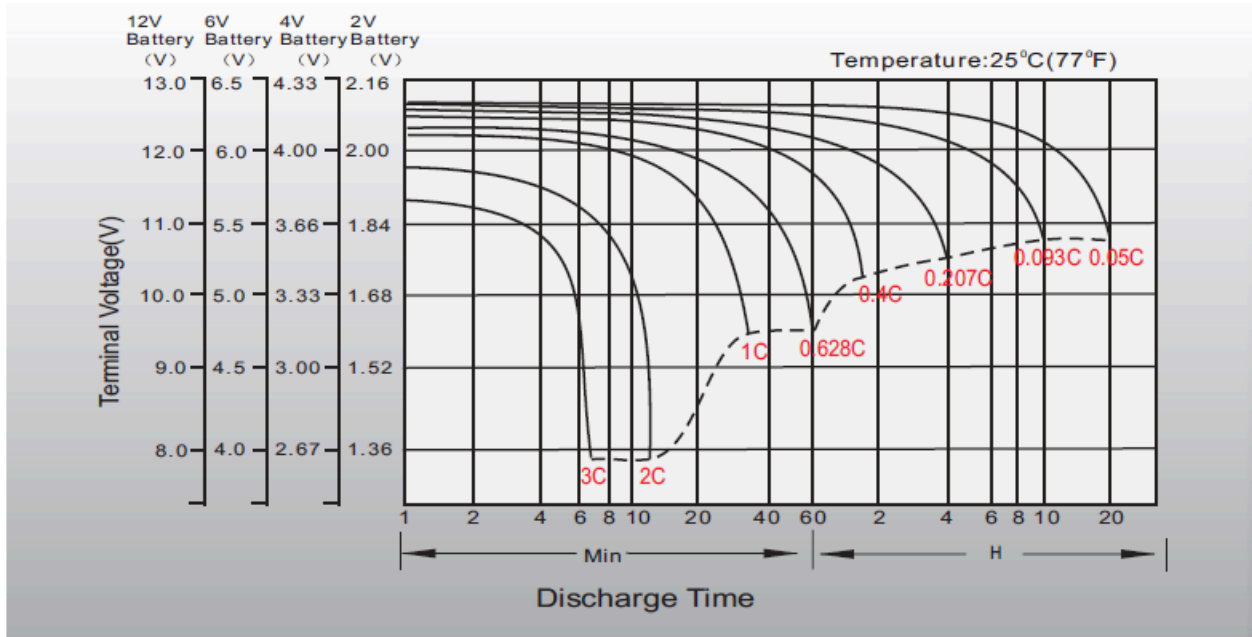

Battery discharge characteristic, always starting from maximum nominal charge, versus the consumption demanded by the supplied load.

The chart above illustrates the discharge-characteristic information of this type of battery, always starting from its maximum nominal charge, and the consumption demanded by the load that will be powered by it.

Note that with a draw of $0.05 \times C$ (C = nominal capacity = 4.5 Ah), i.e. 225 mAh, a new battery at 100% charge operating at 25 °C has its complete discharge estimated at around 20 hours. However, this applies to a battery in ideal conditions. Over its service life, batteries will deteriorate and lose their ideal capacity characteristics as a result of normal use. Therefore a new battery has the characteristics above, but over its time of use these characteristics undergo a reduction until we reach the point of replacing the battery with a new one, as it is no longer possible to obtain a satisfactory runtime performance, as will be addressed further on.

Cycle Life in Relation to Depth of Discharge

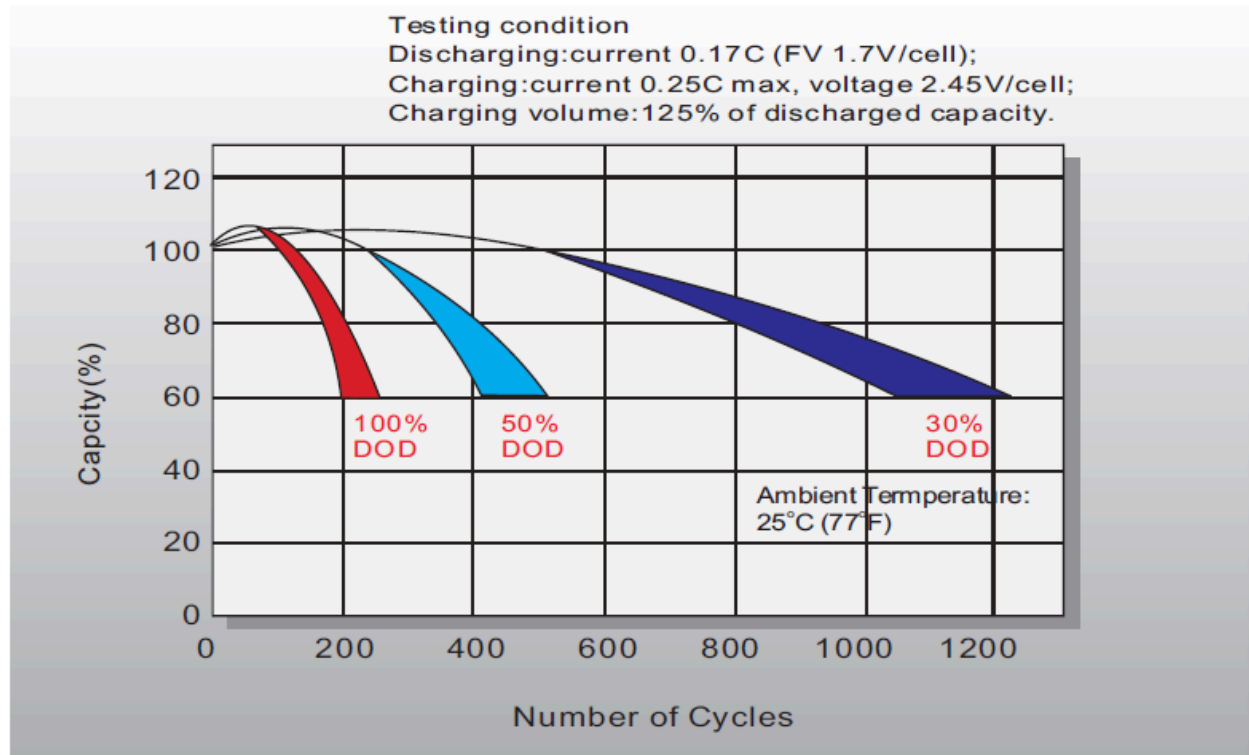

Battery life cycle: number of charge/discharge cycles to reach end-of-life, as a function of depth of discharge (100%, 50% and 30%).

Regarding the life cycle of a battery of this type, it is common to try to estimate a linear time in months or years; however, what actually dictates the service life is the number of charges and discharges the battery undergoes, as well as the way this process occurs.

The chart above illustrates this type of information, where understanding it can allow the user to organise their process to extend battery service life as much as possible through staggering of equipment, scheduling battery-charging routines, and verifying compliance with the times required to always let the equipment charge the battery close to its full nominal capacity.

The **red** curve in the chart indicates that if a complete discharge of 100% of the nominal capacity is always carried out and the battery is always recharged to 100%, this same charge/discharge process can be performed about 200 times before the battery loses about 40% of its nominal capacity through deterioration and needs to be replaced.

The **light-blue** curve indicates that if a partial discharge of 50% of the nominal capacity is always carried out and the battery is always recharged to 100%, this same charge/discharge process can be performed about 400 times before the battery loses about 40% of its nominal capacity through deterioration and needs to be replaced.

Finally, the **dark-blue** curve indicates that if a partial discharge of 30% of the nominal capacity is always carried out and the battery is always recharged to 100%, this same charge/discharge process can be performed about 1200 times before the battery loses about 40% of its nominal capacity through deterioration and needs to be replaced, since it will then never again be able to be charged beyond 60% of its original nominal capacity.

Therefore, the recommended good practices to extend battery service life as much as possible are:

- ✓ Avoid completely discharging the battery as much as possible.
- ✓ Always respect the charging time needed to reach at least 90% charge.
- ✓ Avoid use at high temperatures whenever possible.
- ✓ Promote the longest possible charging cycles without interruption.
- ✓ Always monitor the battery's service life closely and preventively to anticipate replacement situations.

6.2 Electrical supply

Wiring diagram of the external-source connector (female):

Pin	Function
1	+12 V
2	GND

6.3 Display

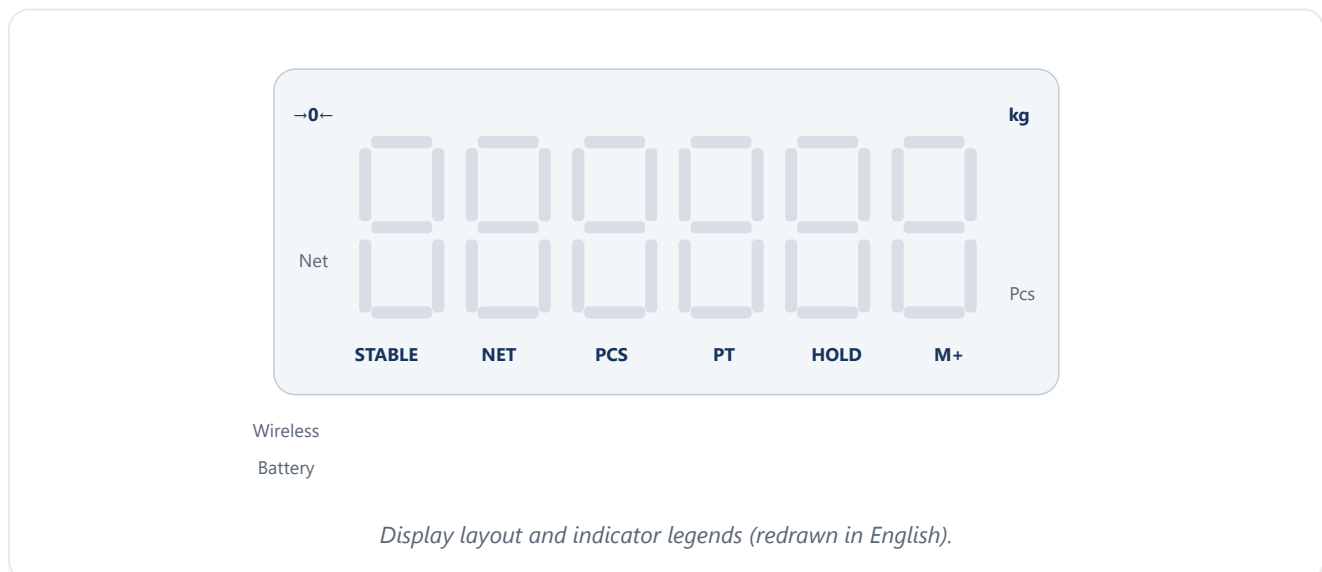

Legend	Meaning
Zero	Zero indication.
"STABLE"	Stability indication.
"NET"	Net-weight display indication.
(sample)	Insufficient-sample indication.

Legend	Meaning
"PT"	Indicates the use of pre-tare.
"HOLD"	Indicates calculated weight or active bed-exit hold.
"PCS"	Piece-counting indication.
"M+"	Indicates weighings accumulated in memory.
Battery	Indicates the battery charge level.
Mains	Indicates connection to the electrical mains.
Bluetooth	Indicates wireless data exchange.

6.4 Manual zero

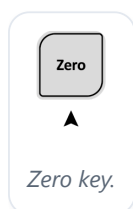

Use the  key to zero the indicator.

6.5 Tare function

The tare function is used to deduct the weight of containers in general.





On pressing the  key, the indicator deducts the weight value shown on the display.

The tare operation is cumulative, that is, it can be performed more than once. To activate the TARE function, the indicator must be showing a positive and stable weight.



To cancel the tare, simply press the  key with no weight applied to the platform.

6.6 Manual tare

The tare function is used to deduct the weight of containers in general, allowing the user to enter the value of the weight to be deducted.

On pressing the  key with no load applied to the scale, the indicator triggers the pre-tare function and the display will show "pt_". Enter the tare value using the , ,  and  keys.

After entering the tare value, simply press the  key to confirm.

To clear the manual tare value, press  with the platform empty, or enter a null tare value by pressing  with no weight applied to the platform.

Manual tare is very useful for deducting the weight of containers whose tare value is already known, thus removing the need to weigh the empty container.

 **Warning** The manual tare value entered cancels any other previously existing tare value.



6.7 Gross and NET weight indication

To switch between gross-weight and net-weight indication on the indicator display, the user must press the  key.

When net weight is shown on the display, the “NET” legend is active.



6.8 Shortcut

Access to the weight-check configuration, FnC-03: press  and  at the same time.

Access to the OP-Relay configuration, FnC-15: press  and  at the same time.

6.9 Piece counting

To use the piece-counting function or to change the reference sample, press the  key.

Select the sample piece quantity by pressing the  key, then place the selected quantity of pieces on the platform and press the  key. The indicator now shows the quantity of pieces on the platform. To switch between piece-counting mode and weighing, press the  key.

 **Warning** Important: the (insufficient-sample) legend indicates that the applied weight is insufficient for the piece calculation; the average weight of each piece cannot be less than 0.2d.

7 User settings

To access the indicator configuration menus, press the **F** and **Zero** keys at the same time.

From the top menu, navigate with the **▼** and **▲** keys:

01 FnC — Access the general user-configuration screens.

02 EC — Parameter not used.

03 rS1 — Access the serial communication-port configuration screens.

00 ESC — Exit the configuration menus.

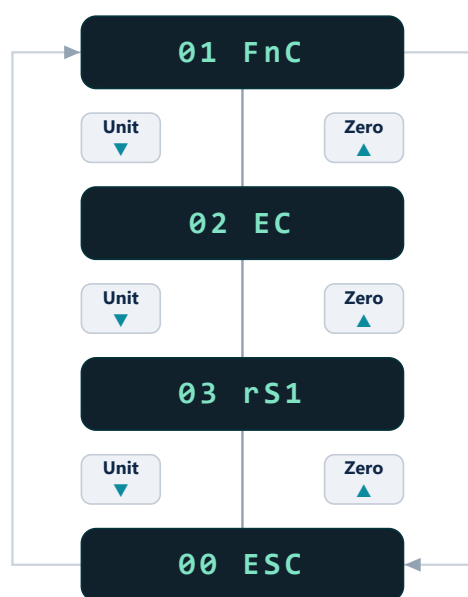

User top-menu navigation flow, scrolled with the Unit (▼) and Zero (▲) keys.

Important Important: To access the configuration menu, the indicator must be in weighing mode.

7.1 User settings

Once at **01 FnC**, press **Tare** and select the parameters from FnC-00 to FnC-13, pressing **Tare** to confirm. Once the parameter is selected, make the desired changes and press **Tare** to confirm.





Use the **◀**, **▼**, **▲** and **▶** keys to navigate between the menu screens.

Parameter	Function	Setting	Description	Default
FnC-00	Return to the previous menu	FnC-00	Return to the previous menu	---.---
FnC-01	Display backlight	bL OFF	Backlight off	bL OFF
		bL On	Backlight on	bL OFF
		–	If the option bL On is selected, the display backlight turns on automatically when the applied weight is greater than 10d and turns off automatically after 10 seconds with no variation in the applied weight.	
FnC-02	Automatic shutdown	A OFF 0	Disabled	A OFF 0
		A OFF 1	Automatic shutdown after 1 minute	A OFF 0
		A OFF 2	Automatic shutdown after 2 minutes	A OFF 0
		A OFF 3	Automatic shutdown after 3 minutes	A OFF 0
		A OFF 4	Automatic shutdown after 4 minutes	A OFF 0
		A OFF 5	Automatic shutdown after 5 minutes	A OFF 0
		A OFF 6	Automatic shutdown after 6 minutes	A OFF 0
		A OFF 7	Automatic shutdown after 7 minutes	A OFF 0
		A OFF 8	Automatic shutdown after 8 minutes	A OFF 0
		A OFF 9	Automatic shutdown after 9 minutes	A OFF 0
FnC-03	Quick-check configuration	000.00h	Upper weight limit	000.00h
		000.00L	Lower weight limit	000.00L
		000.00b	Band value	000.00b
FnC-04	Function not used	---.---	Function not used	---.---

Parameter	Function	Setting	Description	Default
FnC-05	Filters	ZEr0 0	After the scale exceeds 1/3 of the maximum load, forces the return to zero after the weight is removed. (0 to 9 divisions)	ZEr0 0
		FiL 0	Digital filter from 0 to 9. The higher the value, the more stable.	FiL 0
		3db 5	Digital filter from 0 to 9. The higher the value, the faster the indicator response.	3db 5

Parameter	Function	Setting	Description	Default
FnC-06	Hold function	hoLd 0	Hold function disabled.	hoLd 0
		hoLd 1	Peak-detect mode: the indicator always displays the highest weight value measured. To restart the measurement, remove the applied weight and press any key.	hoLd 0
		hoLd 2	Freezes the weight display when the stability indication is activated. To restart the measurement, remove the applied weight and press any key.	hoLd 0
		hoLd 3	Freezes the weight display when the stability indication is activated. The measurement restarts when the measured weight is less than 10d.	hoLd 0
		hoLd 4	Animal-weighing mode. At zero the display shows “---,---”; when a load is applied the indicator immediately starts calculating the applied load, returning to “---,---” when the measured load is less than 10d. After activating the animal-weighing function it is necessary to configure the parameters for the weight calculation.	hoLd 0
		hoLd 5	Animal-weighing mode 2. When a load is applied the indicator immediately starts calculating the weight; when the calculation finishes the indicator activates the “HOLD” legend. After activating the animal-weighing function it is necessary to configure the parameters for the weight calculation.	hoLd 0
		hoLd 6	Tare for hospital beds and bed-exit tolerance. The hospital-bed tare allows items to be placed on and removed from the platform without the net weight being changed. To do this, press the F key before handling any object on the platform and press it again after performing the procedure. After activating the hospital-bed tare function it is necessary to configure the applied-weight variation limit that triggers the bed-exit alarm.	hoLd 0





Parameter	Function	Setting	Description	Default
		hoLd 7	Animal-weighing mode 3. When a load is applied the indicator immediately starts calculating the weight; when the calculation finishes the indicator activates the "stable" legend. The calculated weight is constantly updated and shown on the indicator display. On confirming the selection of this weighing mode, the indicator will show 7 sub-items already optimised for live-animal weighing; these parameters must not be modified.	hoLd 0
FnC-07	Unit average weight	AvErG0	Automatic unit average weight	AvErG0
		AvErG1	Automatic unit average weight disabled	AvErG0
FnC-08	Function not used	---.---	Function not used	---.---
FnC-09	Function not used	---.---	Function not used	---.---
FnC-10	Initial zero memory	Z oFF	Zero memory disabled	Z oFF
		Z on	Zero memory enabled	Z oFF
		—	Important: This function is only available if parameter CFn 02 is different from 4.	
FnC-11	Link function to the pedal	ZErO	Zeroes the scale.	ZErO
		tArE	Deducts the tare value.	ZErO
		Print	Performs the accumulation of the weight value shown on the display and sends the weight value through the serial port.	ZErO

Parameter	Function	Setting	Description	Default
FnC-12	Link function to the F key	mC	Erases records of the accumulations performed.	
		hr	For 5 seconds the weight is shown with one extra decimal place.	
		t-tP	Activates the pre-tare function.	
		t-b	Activates the bed-exit alarm function (FnC 06 – hold 6).	
		r-HOLD	Starts a new weight calculation for live-animal weighing.	
FnC-13	Limit for ZERO-key actuation (can be accessed only when FnC-06 = hold 6)	oFF	Defines the limit for actuation of the  key. After the display shows the message "oFF", press the  key to define the actuation range of the  key. 0% – 30% of the maximum capacity.	oFF
FnC-14	—	—	—	
FnC-15	Set points for use with the OP-Relay	SP oFF	Set the function to on or oFF; confirm with the  key to access the set-point parameters or to return. The corresponding digital output stays active while the measured weight is between the specified limits.	oFF

7.2 Serial communication

Once at , press  to select the parameters from rS1-00 to rS1-12, pressing  to access them.

Once the parameter is selected, make the desired changes and press  to confirm.

Use the , ,  and  keys to navigate between the menu screens.

Parameter	Function	Setting	Description	Default
rS1-00	Return to the previous menu	rS1-00	Return to the previous menu	---.---

Parameter	Function	Setting	Description	Default
rS1-01	Baud-rate configuration	b 600	Transmission speed	b 9600
		b 1200	Transmission speed	b 9600
		b 2400	Transmission speed	b 9600
		b 4800	Transmission speed	b 9600
		b 9600	Transmission speed	b 9600
rS1-02	Parity, stop-bit and length configuration	n81	No parity, 8 data and 1 stop bit	n81
		E71	Even parity, 7 data and 1 stop bit	n81
		071	Odd parity, 7 data and 1 stop bit	n81

Parameter	Function	Setting	Description	Default
rS1-03	Transmission-format configuration	F-m 0	Display value	F-m 0
		F-m 1	Gross weight only	F-m 0
		F-m 2	Net weight only	F-m 0
		F-m 3	Display value (simple format)	F-m 0
		F-m 4	Gross weight only (simple format)	F-m 0
		F-m 5	Net weight only (simple format)	F-m 0
		F-m 6	Hi, Lo or OK status and display value (simple format)	F-m 0
		F-m 7	Hi, Lo or OK status and gross weight (simple format)	F-m 0
		F-m 8	Hi, Lo or OK status and net weight (simple format)	F-m 0
		F-m 9	Tare value	F-m 0
		F-m 10	Weighing number, date, time, gross weight, tare, net weight (the accumulated total weight is sent only when the weighing memory is cleared)	F-m 0
		F-m 11	Date, time, gross weight, tare, net weight (the accumulated total weight is sent only when the weighing memory is cleared)	F-m 0
		F-m 12	Format for the giant remote display DR-WT 75, 125 and 200	F-m 0
		F-m 13	Print format for labels	F-m 0
		F-m 14	Stability status, gross weight, tare, net weight and unit of measure	F-m 0
		F-m 15	Format with identification reader and Bluetooth transmission	F-m 0
F-m 16	Serial transmission format according to the protocol developed by SMA (1999).	F-m 0		

Parameter	Function	Setting	Description	Default
		F-m 17	ESC P transmission format containing: date, time, number of weighings, accumulated total weight, net weight, gross weight and tare	F-m 0
		F-m 20	Format T-02 (P-03 with CheckSum)	F-m 0
		F-m 21	Format T-22 (MP85 Systec)	F-m 0
rS1-04	Transmission-mode configuration	ComAnd	Parameter not used	StrEAn
		StrEAn	Continuous transmission	StrEAn
		Auto	Automatic transmission	StrEAn
		rS-offF	Disables serial communication	StrEAn
		n_PLuS	Transmission in accumulation mode	StrEAn
		rELAY	Use with the OP-Relay (4 digital outputs)	StrEAn
rS1-05	Transmission-frequency configuration	rPS 1	1 transmission per second	rPS 4
		rPS 2	2 transmissions per second	rPS 4
		rPS 4	4 transmissions per second	rPS 4
		rPS 8	8 transmissions per second	rPS 4
		rPS 16	16 transmissions per second	rPS 4
		mAx	Maximum transmissions per second	rPS 4
rS1-06	Minimum weight for automatic transmission	Zb-00 to Zb-99	Minimum weight for automatic transmission. Determines the minimum number of divisions for the automatic transmission of a weight value. Note: if this value is 0, automatic transmission is cancelled.	Zb-05
rS1-07	Automatic-transmission reset configuration	V-b 00 to V-b 99	Automatic-transmission reset. Determines the minimum number of divisions for the reset of the automatic transmission. Note: if this value is 0, the transmission reset is cancelled.	V-b 00

Parameter	Function	Setting	Description	Default
rS1-08	Transmission-condition configuration	ALL-P	Transmission at any weight status	StP-P
		StP-P	Transmission only with stable weight	StP-P
		StoL-P	Transmission of stable weight and OL	StP-P
rS1-09	Weight-information length configuration	Six	6 digits	Six
		SEvEn	7 digits	Six
rS1-10	Internal-clock configuration	yy/mm/dd	Date setting	---.---
		hh/mm/ss	Time setting	---.---
rS1-11	Date-format configuration	y_m_d	Year/month/day	y_m_d
		d_m_y	Day/month/year	y_m_d
rS1-12	Address configuration	Id 00	Indicator address configuration. Valid only for RS-485 communication.	Id 00
rS1-13	Trailing-spaces configuration at end of transmission	n 00	Defines the number of LF characters transmitted after the data is sent. Valid only if rS1-03 = Fm-10 or Fm-11.	n 00
rS1-14	Reset of the TCP/IP or Wi-Fi interface configuration	CAnCEL	Press the key for the option rELoAd to appear, then press the key to confirm. At the end of the process the indicator will show the message oK.	CAnCEL

8 Transmission-format details

Parameter rS1-03. Example showing the function of each part of the transmission format:

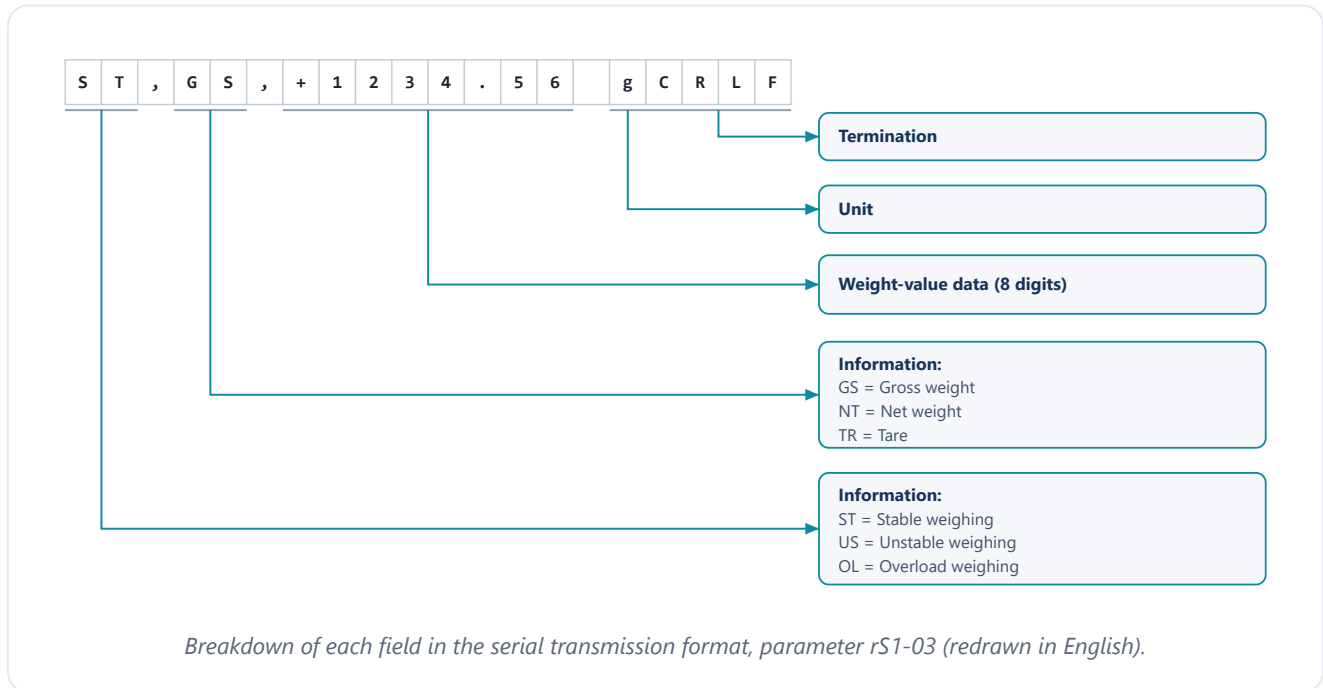

8.1 Transmission examples

Examples of the transmission format with 7 weight bytes (F-m 0, F-m 1, F-m 2 and F-m 9):

Gross	S	T	,	G	S	,	+	SP	SP	3	0	0	.	0	0	SP	SP	k	g	CR	LF
Net	S	T	,	N	T	,	+	SP	SP	2	0	0	.	0	0	SP	SP	k	g	CR	LF
Tare	S	T	,	T	R	,	+	SP	SP	1	0	0	.	0	0	SP	SP	k	g	CR	LF
Overload	O	L	,	G	S	,	+	SP	SP	SP	SP	SP	SP	SP	SP	SP	SP	SP	SP	CR	LF
Negative overload	O	L	,	G	S	,	-	SP	SP	SP	SP	SP	SP	SP	SP	SP	SP	SP	SP	CR	LF

Examples of the transmission format with 6 weight bytes (F-m 0, F-m 1, F-m 2 and F-m 9):

Gross	S	T	,	G	S	,	+	SP	3	0	0	.	0	0	SP	SP	k	g	CR	LF
Net	S	T	,	N	T	,	+	SP	2	0	0	.	0	0	SP	SP	k	g	CR	LF
Tare	S	T	,	T	R	,	+	SP	1	0	0	.	0	0	SP	SP	k	g	CR	LF
Overload	O	L	,	G	S	,	+	SP	SP	SP	SP	SP	SP	SP	SP	SP	SP	SP	CR	LF
Negative overload	O	L	,	G	S	,	-	SP	SP	SP	SP	SP	SP	SP	SP	SP	SP	SP	CR	LF

Examples of the simple transmission format with 7 weight bytes (F-m 0, F-m 1, F-m 2 and F-m 9):

Gross	+	SP	SP	3	0	0	.	0	0	CR	LF
Net	+	SP	SP	2	0	0	.	0	0	CR	LF

	Tare	+	SP	SP	1	0	0	.	0	0	CR	LF
	Overload	+	SP	SP	SP	SP	SP	SP	SP	SP	CR	LF
	Negative overload	-	SP	SP	SP	SP	SP	SP	SP	SP	CR	LF

Examples of the simple transmission format with 6 weight bytes (F-m 0, F-m 1, F-m 2 and F-m 9):

	Gross	+	SP	3	0	0	.	0	0	CR	LF
	Net	+	SP	2	0	0	.	0	0	CR	LF
	Tare	+	SP	1	0	0	.	0	0	CR	LF
	Overload	+	SP	SP	SP	SP	SP	SP	SP	CR	LF
	Negative overload	-	SP	SP	SP	SP	SP	SP	SP	CR	LF

Examples of the transmission format with check-weigher status and weight in the simple format (F-m 6, F-m 7 and F-m 8):

	Status above	1	0	0	+	.	2	3	.	4	5	6	CR	LF
	Status OK	0	1	0	+	.	2	3	.	4	5	6	CR	LF
	Status below	0	0	1	+	.	2	3	.	4	5	6	CR	LF

Example of the transmission format with weighing number, date, time, gross weight, tare and net weight (accumulated total weight is sent when the weighing memory is cleared) — F-m 10:

T	I	C	K	E	T	SP	SP	N	0	.	0	0	0	1	CR	LF
D	A	T	E	:	2	0	1	3	/	1	1	/	0	1	CR	LF
T	I	M	E	:	SP	SP	1	2	:	3	3	:	4	5	CR	LF
G	SP	+	SP	SP	SP	SP	SP	3	3	.	0	0	k	g	CR	LF
T	SP	+	SP	SP	SP	SP	SP	1	1	.	0	0	k	g	CR	LF
N	SP	+	SP	SP	SP	SP	SP	2	2	.	0	0	k	g	CR	LF

Totalisation format for the weighings performed (sent only when the weighing memory is cleared):

T	O	T	A	L	SP	N	U	M	B	E	R	CR	LF			
O	F	SP	T	I	C	K	E	T	S	SP	0	0	0	0	CR	LF
D	A	T	E	:	2	0	1	3	/	1	1	/	0	1	CR	LF
T	I	M	E	:	SP	SP	1	2	:	3	3	:	4	5	CR	LF
G	SP	+	SP	SP	SP	SP	SP	3	3	.	0	0	k	g	CR	LF
T	SP	+	SP	SP	SP	SP	SP	1	1	.	0	0	k	g	CR	LF
N	SP	+	SP	SP	SP	SP	SP	2	2	.	0	0	k	g	CR	LF
CR	LF															

T	O	T	A	L	SP	N	E	T	CR	LF							
SP	SP	+	SP	SP	SP	2	2	2	2	.	0	0	k	g	CR	LF	

Example of the transmission format with date, time, gross weight, tare and net weight (accumulated total weight is sent when the weighing memory is cleared) — F-m 11:

D	A	T	E	:	2	0	1	3	/	1	1	/	0	1	CR	LF	
T	I	M	E	:	SP	SP	1	2	:	3	3	:	4	5	CR	LF	
G	SP	+	SP	SP	SP	SP	SP	3	3	.	0	0	k	g	CR	LF	
T	SP	+	SP	SP	SP	SP	SP	1	1	.	0	0	k	g	CR	LF	
N	SP	+	SP	SP	SP	SP	SP	2	2	.	0	0	k	g	CR	LF	

Totalisation format for the weighings performed (sent only when the weighing memory is cleared):

T	O	T	A	L	SP	N	U	M	B	E	R	CR	LF				
O	F	SP	T	I	C	K	E	T	S	SP	0	0	0	0	CR	LF	
D	A	T	E	:	2	0	1	3	/	1	1	/	0	1	CR	LF	
T	I	M	E	:	SP	SP	1	2	:	3	3	:	4	5	CR	LF	
G	SP	+	SP	SP	SP	SP	SP	3	3	.	0	0	k	g	CR	LF	
T	SP	+	SP	SP	SP	SP	SP	1	1	.	0	0	k	g	CR	LF	
N	SP	+	SP	SP	SP	SP	SP	2	2	.	0	0	k	g	CR	LF	
CR	LF																
T	O	T	A	L	SP	W	E	I	G	H	T	CR	LF				
SP	SP	+	SP	SP	SP	2	2	2	2	.	0	0	k	g	CR	LF	

Transmission format of stability status, gross weight, tare and net weight — F-m 14:

S	,	B	B	B	B	.	.	B	B	B	,	T	T	T	.	T	T	T	,	L	L	L	.	L	L	L	L	CR	LF
---	---	---	---	---	---	---	---	---	---	---	---	---	---	---	---	---	---	---	---	---	---	---	---	---	---	---	---	----	----

Field	Description
S	Stability flag, which can take the following values: 0 = stable weight; 1 = unstable weight.
B	7 bytes of gross weight including the decimal point and the negative-weight sign.
T	7 bytes of tare weight including the decimal point and the negative-weight sign.

Field	Description
L	7 bytes of net weight including the decimal point and the negative-weight sign.
CR	Carriage return (0x0D).
LF	Line feed (0x0A).

F-m 17:

P	e	s	a	g	e	m	:	A	A	A	A	A	A	A	<CR>	<LF>		
D	a	t	a	:	d	d	/	M	M	/	y	y	<CR>	<LF>	
H	o	r	a	:	h	h	:	m	m	:	s	s	<CR>	<LF>	
P	e	s	o	<i>SP</i>	B	r	u	t	o	:	g	g	g	g	g	g	g	U	U	<CR>	<LF>
P	e	s	o	<i>SP</i>	L	i	q	u	i	d	o	.	.	.	:	n	n	n	n	n	n	n	U	U	<CR>	<LF>
T	a	r	a	:	t	t	t	t	t	t	t	U	U	<CR>	<LF>
T	o	t	a	l	<i>SP</i>	a	c	u	m	u	l	a	d	o	:	w	w	w	w	w	w	w	U	U	<CR>	<LF>

- "A" (7 bytes) — Number of accumulations;
- "dd/MM/yy" — Date (day/month/year);
- "hh:mm:ss" — Time (hour:minute:second);
- "g" (7 bytes) — Gross weight;
- "n" (7 bytes, padded with spaces <SP> on the left) — Net weight;
- "t" (7 bytes, padded with spaces <SP> on the left) — Tare weight;
- "w" (7 bytes, padded with spaces <SP> on the left) — Total accumulated weight;
- "U" (2 bytes) — Measurement unit (kg, lb, oz and others allowed by the indicator).

F-m 20 — Format T-02 (P-03 with CheckSum):

ABREVIATURAS:

STX	Start of Text	02H
CR	Carriage Return	0DH
(CS)	Byte de Checksum (APENAS SE RSX-01 = 22)	
I	Peso indicado no Display (Líquido ou Bruto)	
T	Tara	

FORMATO DOS DADOS:

STX,SWA,SWB,SWC,I,I,I,I,I,I,T,T,T,T,T,T,CR,(CS)

SWA - STATUS WORD "A":

BIT 2, 1 e 0:	001 = DISPLAY x 10 010 = DISPLAY x 1 011 = DISPLAY x 0.1 100 = DISPLAY x 0.01 101 = DISPLAY x 0.001 110 = DISPLAY x 0.0001
BIT 4 e 3:	01 = TAMANHO DO INCREMENTO É 1 10 = TAMANHO DO INCREMENTO É 2 11 = TAMANHO DO INCREMENTO É 5
BIT 6 e 5:	01 SEMPRE
BIT 7:	PARIDADE PAR

SWB - STATUS WORD "B":

BIT 0:	PESO LÍQUIDO = 1
BIT 1:	PESO NEGATIVO = 1
BIT 2:	SOBRECARGA = 1
BIT 3:	EM MOVIMENTO = 1
BIT 4:	SEMPRE = 1
BIT 5:	SEMPRE = 1
BIT 6:	SEMPRE = 0
BIT 7:	PARIDADE PAR

SWC - STATUS WORD "C":

BIT 0:	SEMPRE = 0
BIT 1:	SEMPRE = 0
BIT 2:	SEMPRE = 0
BIT 3:	TECLA IMPRIMIR = 1
BIT 4:	EXPANDIDO = 1
BIT 5:	SEMPRE = 1
BIT 6:	TARA MANUAL = 1
BIT 7:	PARIDADE PAR

ATENÇÃO: Se houver sobrecarga, o campo de peso IIIIIII apresenta 000000.

Format T-02 (P-03 with CheckSum) byte structure.

F-m 21 — Format T-22 (MP85 Systemc). Recommended serial-interface configuration:

- ▶ RS1-01 = 9600
- ▶ RS1-02 = n81
- ▶ RS1-03 = f-m21
- ▶ RS1-04 = Command
- ▶ RS1-05 = rpS4
- ▶ RS1-06 = Z-b05
- ▶ RS1-07 = v-b00
- ▶ RS1-08 = ALL-P
- ▶ RS1-09 = SiX

Command structure:

Data string PC → Weighing terminal

STX	Command	ETX
-----	---------	-----

Data string weighing terminal → PC:

STX	Status byte	Data	CR	ETX	ACK
-----	-------------	------	----	-----	-----

T-22 command structure.

Commands:

Command	Description
STX @G ETX	Read weight
STX @T ETX	Autotare
STX @B ETX	Clear tare
STX @Z ETX	Set scale to zero

T-22 command set.

Responses — Command @G:

Command

Field	Byte	Char's	Description	Example
STX	1	1	Start character	STX
@G	2	2	Command	@G
ETX	4	1	End character	ETX

In total: 4

Response

Field	Byte	Char's	Description	Example
STX	1	1	Start character	STX
Status byte (P)	2	1	See table 'Status bytes'	P
Weight	3	6	with decimal point	+21.22
CR	9	1	Carriage Return (hex 13)	CR
ETX	10	1	End character	ETX
ACK	11	1	Acknowledge (hex 6)	ACK

In total: 11

Response to command @G.

Command @T:

Command

Field	Byte	Char's	Description	Example
STX	1	1	Start character	STX
@T	2	2	Command	@T
ETX	4	1	End character	ETX

In total: 4

Response

Field	Byte	Char's	Description	Example
ACK	1	1	Acknowledge (hex 6)	ACK

In total: 1

Response to command @T.

Command @B:

Command

Field	Byte	Char's	Description	Example
STX	1	1	Start character	STX
@B	2	2	Command	@B
ETX	4	1	End character	ETX

In total: 4

Response

Field	Byte	Char's	Description	Example
ACK	1	1	Acknowledge (hex 6)	ACK

In total: 1

Response to command @B.

Command @Z:

Command

Field	Byte	Char's	Description	Example
STX	1	1	Start character	STX
@Z	2	2	Command	@Z
ETX	4	1	End character	ETX

In total: 4

Response

Field	Byte	Char's	Description	Example
ACK	1	1	Acknowledge (hex 6)	ACK

In total: 1

Response to command @Z.

Status bytes:

Status byte	Value = 1	Value = 0
Bit 1	Invalid weight	Valid weight
Bit 2	Net	Gross
Bit 3	Weight = 0 (+/-1/4 d)	Weight not zero
Bit 4	Weight out of range	Weight within range
Bit 5	Settled	Motion
Bit 6	Weight below min. load	Weight above min. load
Bit 7	always "1" -> status is printable character	

Key to most frequently encountered status bytes:

@	gross, motion, within range, above min. load
B	net, motion, within range, above min. load
P	gross, settled, within range, above min. load
R	net, settled, within range, above min. load
'	gross, motion, below min. load, within range
b	net, motion, within range, below min. load
d	gross, motion, zero, within range, below min. load
p	gross, settled, within range, below min. load
r	net, settled, within range, below min. load
t	gross, settled, zero, within range, below min. load
v	net, settled, zero, within range, below min. load
A	no weight or no valid weight on display (e.g. Error)
l	out of range
H	out of range

T-22 status bytes.

8.2 Serial remote commands

Command	Function performed on the indicator
MZ	Zero
MT	Tare
CT	Clears an active tare value
MG	Gross-weight indication on the display
MN	Net-weight indication on the display
SC	Starts continuous transmission

Command	Function performed on the indicator
SA	Starts automatic transmission
SO	Activates command mode
%	Ends continuous transmission and enters command mode
RW	Sends the current weight value shown on the display
RG	Sends the current gross-weight value
RN	Sends the current net-weight value
RT	Sends the current tare value
RB	Sends the current weight value shown on the display (simple format)
RH	Sends the current gross-weight value (simple format)
RI	Sends the current net-weight value (simple format)
RJ	Sends the current tare value (simple format)
RK	Sends the comparison status (check weigher) and the gross weight
RL	Sends the comparison status (check weigher) and the net weight
PT	Sends a pre-tare value, entered after the command. Example: PT,000000CRLF

 **Important** Notes:

- Commands must be followed by the terminators CR (0Dh) and LF (0Ah).
- When a command is not accepted or is not correct, an error indication is sent in the format: E: (character sent).
- When a command is accepted, the command is echoed by the indicator immediately after execution.
- To use commands with an address, configure rS1-12 and place the @ character in front of each command (e.g. @MZ).

Example of transmission in the Zebra printer format — if linked to the function “print accumulated and number of accumulated weighings” (F-m 13):

Transmission example
FR" IRWT3000"

Transmission example
?
0000500
0000200
0000300
0000012
0005000
19/07/09
15:37:45
00000120008,750190709153745
P1,1

Example of transmission — if linked to the function “print accumulated and number of accumulated weighings” (F-m 15):

Transmission example
FR" CATTLE"
?
000020004578978458520235785
0000500
0000200
0000300
0000012
0005000
19/07/09
15:37:45
00000120008,750190709153745

Transmission example

P1,1

9 Calibration parameters

Warning Attention: access to these functions is blocked by a jumper located on the indicator's main board.

9.1 Accessing the calibration switch

- 1 Turn off the indicator;
- 2 Loosen the screws that secure the rear cover of the indicator;
- 3 Move the switch from the "LOCK" position to the "ADJ." position;
- 4 Refit the access cover on the indicator;
- 5 Turn on the indicator.



Calibration switch (LOCK / ADJ.) on the main board.

Once the configuration and calibration procedures are complete, close the indicator's access cover.

9.2 Configuration and calibration menus

Once the indicator is turned on with the calibration switch in the "ADJ." position, the indicator shows the message

01 CSP

01 CSP — Menu for capacity and division configuration.

02 CAL — Calibration menu.

03 CLn — Parameter not used.

04 CFn — Menu for configuring filter and auto-zero functions.

06 CGr — Parameter not used.

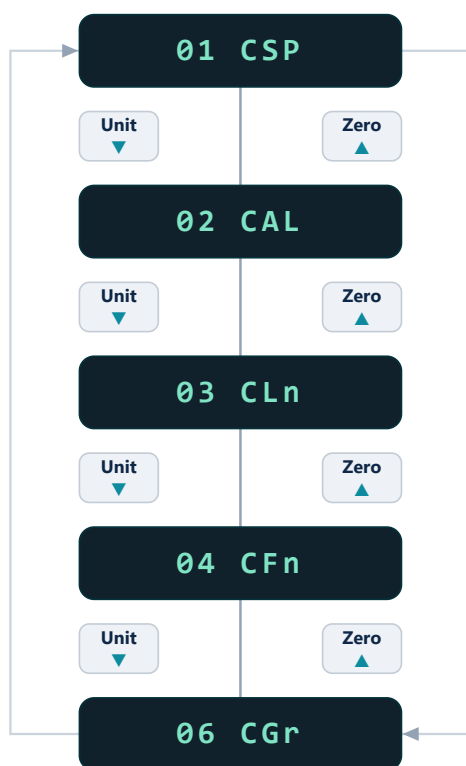







Calibration top-menu navigation flow, scrolled with the Unit (▼) and Zero (▲) keys.

9.3 Capacity and division configuration







Once at **01 CSP**, press **Tare** to access the parameters CSP-00 to CSP-03, pressing **Tare** to confirm. Once the parameter is selected, make the desired changes and press **Tare** to confirm. Use the **◀**, **▼**, **▲** and **▶** keys to navigate between the menu screens.

Parameter	Function	Setting	Description	Default
CSP-00	Return to the previous menu	CSP-00	Return to the previous menu	---.---
CSP-01	Indication unit / Capacity / Division and decimal point	u00000	100001 = indication in grams (g) / 000001 = indication in kilograms (kg)	u00000
		C00000	Enter the capacity, with decimal places, without the comma	C00000
		d00000	$d0_a0_b0_c0_d0_e0_f$ — digit "a" indicates the increment (1, 2 or 5); digit "b" indicates the position of the decimal point (0 to 5); digit "e" multiplies the increment by 10 (weighbridge); digits "c", "d" and "f" must always be equal to "0".	d00000
CSP-02	Function not used	---.---	Function not used	---.---
CSP-03	Function not used	---.---	Function not used	---.---







9.4 Calibration

Once at **02 CAL**, press  and select the parameters CAL-00 to CAL-02, pressing  to confirm. Once the parameter is selected, make the desired changes and press  to confirm. Use the , ,  and  keys to navigate between the menu screens.

Parameter	Function	Setting	Description	Default
CAL-00	Return to the previous menu	CAL-00	Return to the previous menu	---.---

Parameter	Function	Setting	Description	Default
CAL-01	Calibration weight / Zero calibration / Span	000.000	The indicator shows the calibration weight according to the CSP-01 settings. Enter the calibration-weight value using the  ,  ,  and  keys.	000.000
		-----	After entering the weight value for calibration, empty the scale platform and press the  key.	-----
		000.000	The indicator shows the calibration weight flashing continuously. Apply the weight on the platform and then press the  key. At the end of calibration the indicator returns to the previous menu "02 CAL".	000.000
CAL-02	Function not used	---.---	Function not used	---.---

9.5 Filter and auto-zero function configuration

Once at **04 CFn**, press  and select the parameters CFn-00 to CFn-06, pressing  to access. Once the parameter is accessed, edit it and press  to confirm. Use the , ,  and  keys to navigate between the menu screens.

Parameter	Function	Setting	Description	Default
CFn-00	Return to the previous menu	CFn-00	Return to the previous menu	---.---
CFn-01	Filters	ZErO 0	After the scale exceeds 1/3 of the maximum load, forces the return to zero after the weight is removed.	ZErO 0
		FiL 0	Digital filter from 0 to 9. The higher the value, the more stable.	FiL 0
		3db 5	Digital filter from 0 to 9. The higher the value, the faster the indicator response.	3db 5

Parameter	Function	Setting	Description	Default
CFn-02	Model approval	ProvE 0	Non-approved models (allows external calibration)	ProvE 4
		ProvE 1	OIML- or NTEP-approved models	ProvE 4
		ProvE 2	Models approved in Sri Lanka (zero acceptable within a range of $\pm 3\%$ of the adjusted point)	ProvE 4
		ProvE 3	Models approved in Sri Lanka (zero acceptable within a range of $\pm 3\%$ of the adjusted point)	ProvE 4
		ProvE 4	Models approved in Brazil (does not allow counting of pieces smaller than 0.1e)	ProvE 4
		ProvE 5	With tare active, pressing the "Net/Gross" key shows the gross weight for 5 seconds and then returns to the net weight.	ProvE 4
CFn-03	Function not used	---.---	Function not used	---.---
CFn-04	Function not used	---.---	Function not used	---.---

Parameter	Function	Setting	Description	Default
CFn-05	Hold function	hoLd 0	Hold function disabled.	hoLd 0
		hoLd 1	Peak-detect mode: the indicator always displays the highest weight value measured. To restart the measurement, remove the applied weight and press any key.	hoLd 0
		hoLd 2	Freezes the weight display when the stability indication is activated. To restart the measurement, remove the applied weight and press any key.	hoLd 0
		hoLd 3	Freezes the weight display when the stability indication is activated. The measurement restarts when the measured weight is less than 10d.	hoLd 0
		hoLd 4	Animal-weighing mode. At zero the display shows “---.---”; when a load is applied the indicator immediately starts calculating the applied load, returning to “---.---” when the measured load is less than 10d. After activating the animal-weighing function it is necessary to configure the parameters for the weight calculation.	hoLd 0
		hoLd 7	Animal-weighing mode 3. When a load is applied the indicator immediately starts calculating the weight; when the calculation finishes the indicator activates the “stable” legend. The calculated weight is constantly updated and shown on the indicator display. On confirming the selection of this weighing mode, the indicator will show 7 sub-items already optimised for live-animal weighing; these parameters must not be modified.	hoLd 0
CFn-06	Auto-zero	Z-tc 00%	Actuation limit of the zero mechanisms, 0% to 30% of full scale.	Z-tc 0
		Zt-d 00	Actuation limit of the auto-zero function, from 01 to 20 (0.25d to 5d).	Z-tc 0

Parameter	Function	Setting	Description	Default
CFn-08	Tare	Fr9 0~2	Defines the behaviour of the indicator's tare function. 0 = disables the tare function; 1 = allows the tare to be performed only once; 2 = allows successive tares.	Fr9 = 1
		-nt 0~1	Defines the indicator's behaviour when performing a tare with negative values. 0 = enabled; 1 = disabled.	-nt = 0

10 Detailed connections

10.1 Load-cell connection

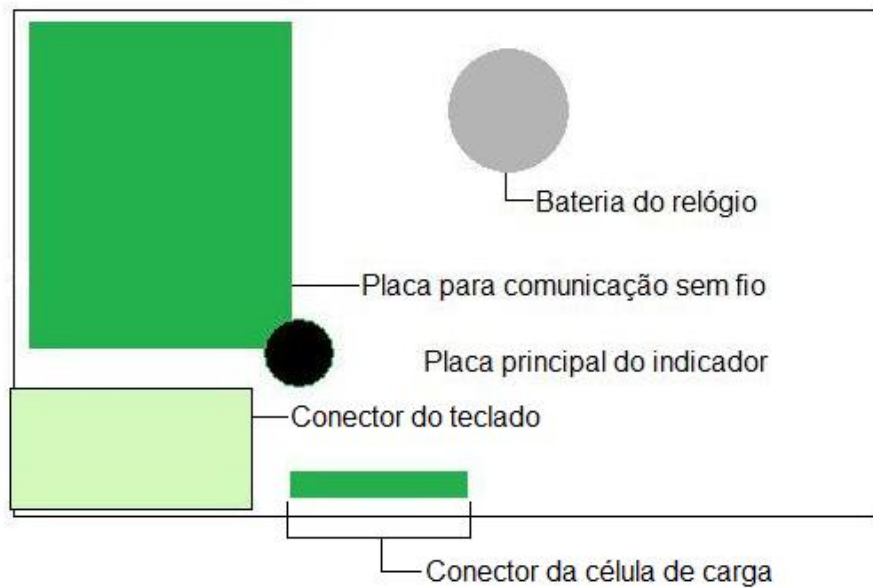

Load-cell connection on the main board.

DIAGRAM LABELS (TRANSLATED):

Bateria do relógio → Clock battery · **Placa para comunicação sem fio** → Wireless communication board ·
Placa principal do indicador → Indicator main board · **Conector do teclado** → Keyboard connector ·
Conector da célula de carga → Load-cell connector

⚠ Warning Attention: to allow the compensation circuit to act, a 6-wire cable must be used and jumpers J17 and J18, located on the front of the main board, must be opened, as shown in the figure below:



Jumpers J17 and J18 on the main board.

Wiring diagram for 6-wire load cells:

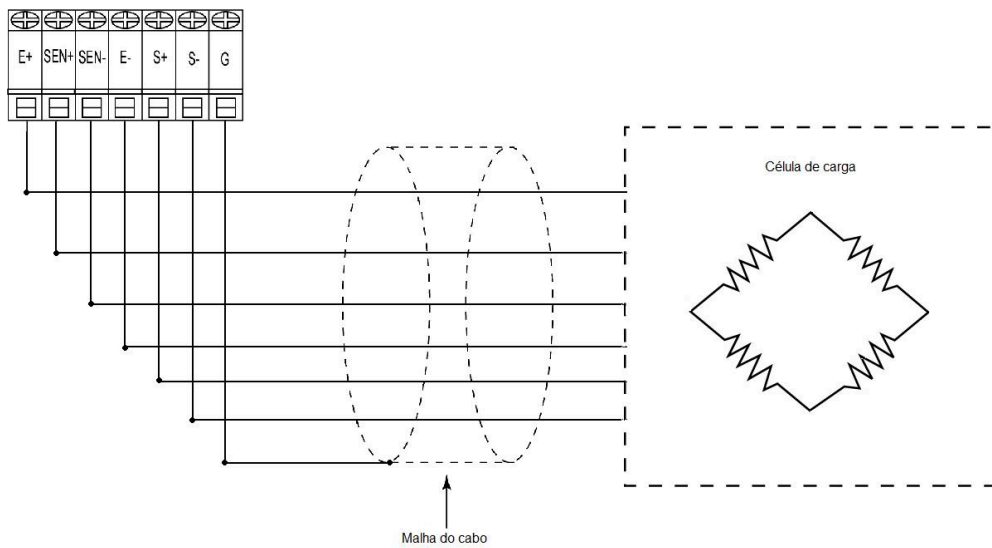

Wiring diagram — 6-wire load cells.

DIAGRAM LABELS (TRANSLATED):

Célula de carga → Load cell · **Malha do cabo** → Cable shield

Wiring diagram for 4-wire load cells:

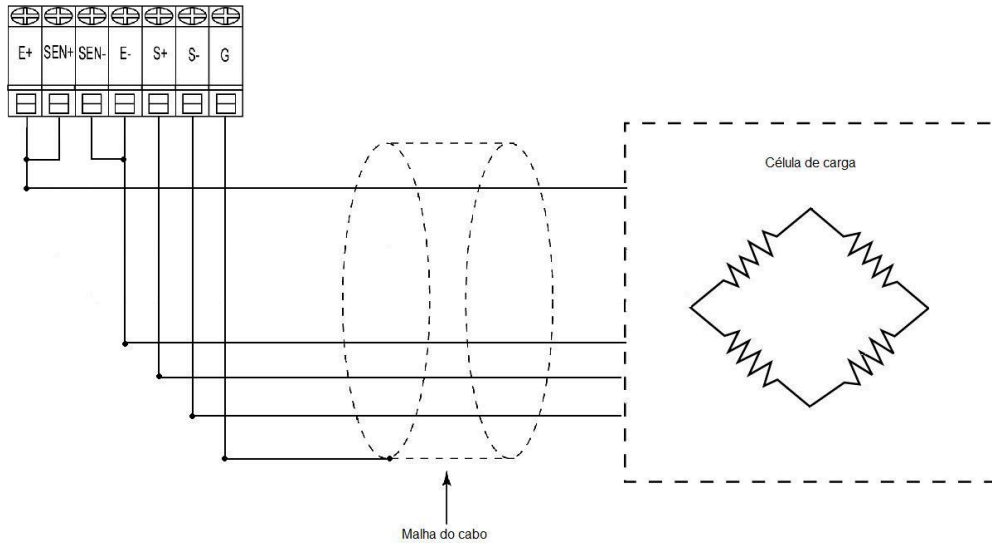

Wiring diagram — 4-wire load cells.

DIAGRAM LABELS (TRANSLATED):

Célula de carga → Load cell · **Malha do cabo** → Cable shield

Wiring diagram for the 7-pin SP21 male circular connector:

Connector	Function
Pin 1	E- and S-
Pin 2	E+ and S+
Pin 3	I-
Pin 4	I+

10.2 Serial-output connections

The serial output is connected through the terminals located on the indicator’s main board, according to the table and figure below:

Connector	DB-9 Female (computer)
Pin 1 (RxD)	Pin 3
Pin 2 (TxD)	Pin 2
Pin 3 (GND)	Pin 5

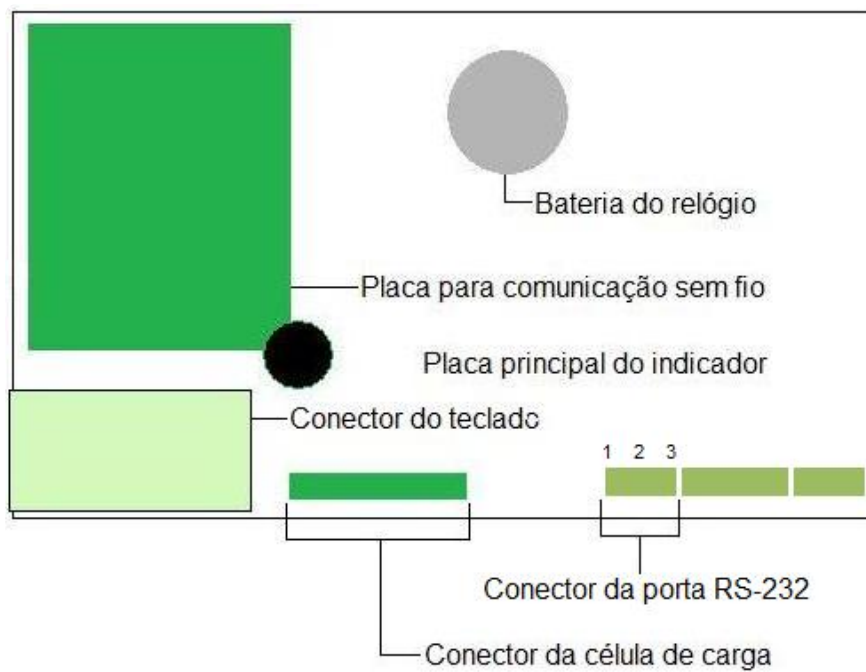

Serial-output wiring.

10.3 Optional serial output 01 (RS-232 or RS-485)

Warning Attention: the optional serial output is supplied separately and cannot be used together with the optional Bluetooth output.

Connection diagram of the optional serial output operating in RS-232:

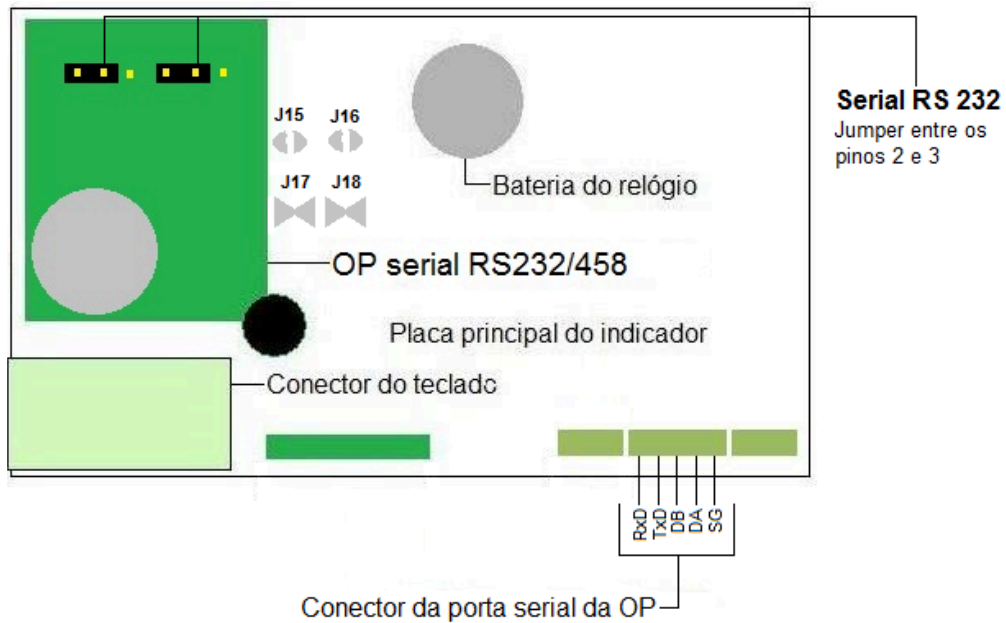

Optional serial output — RS-232 connection.

DIAGRAM LABELS (TRANSLATED):

Serial RS 232 — Jumper entre os pinos 2 e 3 → Serial RS 232 — jumper between pins 2 and 3 · **Bateria do relógio** → Clock battery · **OP serial RS232/458** → OP serial RS232/485 · **Placa principal do indicador** → Indicator main board · **Conector do teclado** → Keyboard connector · **Conector da porta serial da OP** → OP serial-port connector

Connection diagram of the optional serial output operating in RS-485:

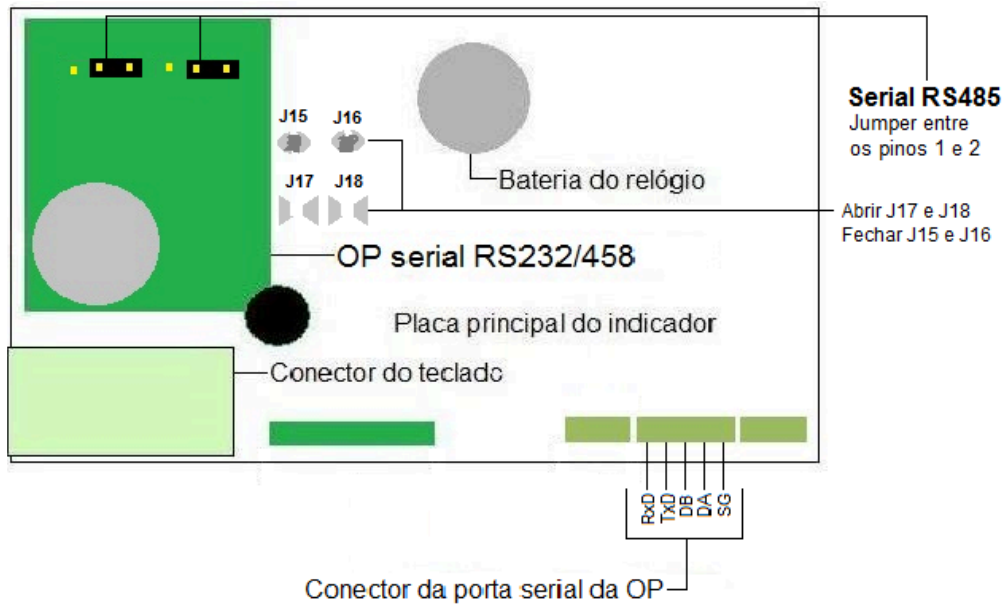

Optional serial output — RS-485 connection.

DIAGRAM LABELS (TRANSLATED):

Serial RS485 — Jumper entre os pinos 1 e 2 → Serial RS485 — jumper between pins 1 and 2 · **Abrir J17 e J18 / Fechar J15 e J16** → Open J17 and J18 / Close J15 and J16 · **Bateria do relógio** → Clock battery · **OP serial RS232/458** → OP serial RS232/485 · **Placa principal do indicador** → Indicator main board · **Conector do teclado** → Keyboard connector · **Conector da porta serial da OP** → OP serial-port connector

10.4 Connection to the Zebra TLP 2844 printer

Printing on the Zebra TLP2844 allows the printing of gross weight, tare, net weight, date, time, number of weighings, accumulated total weight and barcode. The print format is fully customisable and even allows the insertion of the company logo.

10.4.1 PRINTER CONFIGURATION

The printer is configured using the “Zebra Designer” software, which can be obtained free of charge by direct download from the Zebra website. In the ZebraDesigner program, open the file “IRWT3000.LBL”, then export it to the printer through the menu “File” → “Export to printer”.

Important Additionally, the template label IRWT3000.lbl must be downloaded.

Circular connector (indicator)	DB-9 Male (Zebra)
Terminal 3 (GND)	Pin 5
Terminal 2 (TX)	Pin 3

10.5 Remote displays DR-WT75, DR-WT125 and DR-WT200

The remote display's function is to repeat the weight value shown on the indicator.



Remote display.

10.5.1 CONFIGURING THE INDICATOR

- ▶ CFn-02 = 4
- ▶ rS1-01 = b 1200
- ▶ rS1-02 = p n81
- ▶ rS1-03 = F-M 12
- ▶ rS1-04 = StrEAn
- ▶ rS1-05 = rPS 4
- ▶ rS1-08 = ALL-P
- ▶ rS1-09 = SEvEn

10.5.2 CONNECTIONS TO THE REMOTE DISPLAY DR-WT75, DR-WT125 AND DR-WT200

The serial output is connected through the terminal located on the indicator's main board, according to the table below:

Circular connector (indicator)	Circular connector (display)
Terminal 3 (GND)	Pin 5
Terminal 2 (TX)	Pin 3

Circular connector (indicator)	Circular connector (display)
* Remove the factory short between pins 1 and 4 of the display	* Remove the factory short between pins 1 and 4 of the display

10.6 Optional Bluetooth interface 05

Bluetooth communication shares the configuration parameters with the indicator's physical RS-232 port; that is, the parameters applied in **03 rS1** are used in communication via Bluetooth.

The password to connect to the device is "111111".

The Bluetooth communication port becomes active the moment the indicator is turned on and is available to accept connections the moment the indicator enters weighing mode.

10.7 Optional Ethernet TCP/IP interface 07

To access the configuration page of the indicator's Ethernet TCP/IP interface, the network cable must be connected to the same network as the computer that will be used to perform the configuration.

Indicator serial-port settings:

Parameter	Setting
RS1-01	b 9600
RS1-02	P n81
RS1-03	F-m 0
RS1-04	StrEAn
RS1-05	rPS4
RS1-06	Z-b 05
RS1-07	v-b 00
RS1-08	ALL-P
RS1-09	SEvEn



Warning Attention: the OP does not support the use of serial commands.

Perform the steps below to access the TCP/IP interface settings:

- 1 Temporarily disable the system firewall;
- 2 Enable the PC's LAN adapter;
- 3 Make sure the PC is configured to use a fixed IP within the range of the interface's default IP (192.168.0.7).

Default interface configuration:

IP: **192.168.0.7**

Subnet mask: **255.255.255.0**

Gateway: **192.168.0.1**

From your internet browser, go to the address: <http://192.168.0.7> . Use this login data to start the configuration
 — User: **admin** · Password: **admin**.

i Important IMPORTANT: For correct operation of the data transmission from the interface, the indicator's serial transmission settings must be the same as the transmission settings written on the TCP/IP interface configuration page, and jumpers 12 and 15 on the main board must be closed and jumpers 16 and 13 on the main board must be open.

10.8 Optional Ethernet Wi-Fi interface 08

To access the configuration page of the indicator's Ethernet Wi-Fi interface, the computer must be connected to the indicator's network to perform the configuration.

Indicator serial-port settings:

Parameter	Setting
RS1-01	b 9600
RS1-02	P n81
RS1-03	F-m 0
RS1-04	StrEAn
RS1-05	rPS4
RS1-06	Z-b 05
RS1-07	v-b 00
RS1-08	ALL-P
RS1-09	SEvEn

Warning Attention: the OP does not support the use of serial commands.

Perform the steps below to access the Wi-Fi interface settings:

- 1 Temporarily disable the system firewall;
- 2 Enable the PC's wireless network adapter;
- 3 On the PC, open the wireless-network selection panel and select the network "EXID".

Default interface configuration:

SSID: **EXID**

IP address: **10.10.100.254**

Subnet mask: **255.255.255.0**

From your internet browser, go to the address: <http://10.10.100.254> . Use this login data to start the configuration — User: **admin** · Password: **admin**.

Important IMPORTANT: For correct operation of the data transmission from the interface, the indicator's serial transmission settings must be the same as the transmission settings written on the Wi-Fi interface configuration page, and jumpers 12 and 15 on the main board must be closed and jumpers 16 and 13 on the main board must be open.

10.9 OP-Relay interface (4 digital outputs)

The OP-Relay allows the use of up to 4 NO (normally-open) digital outputs that are activated while the measured weight value is within the limits specified by the operator in parameter FnC-15.

Important IMPORTANT: When using the OP-Relay interface, the indicator's serial port becomes unavailable for any other communications.

Warning The interface relays must not be used to perform switching directly; it is recommended that auxiliary relays be installed between this interface and the field switching, with the intention of protecting the weighing instrumentation.

To use the OPxx interface, the indicator's serial port must be configured according to the table below:

Parameter	Setting
RS1-01	b 9600
RS1-02	P n81

Parameter	Setting
RS1-03	F-m 0
RS1-04	rELAY
RS1-05	rPS8
RS1-06	Z-b 05
RS1-07	v-b 00
RS1-08	ALL-P
RS1-09	SEvEn

Connections on the OP-Relay:

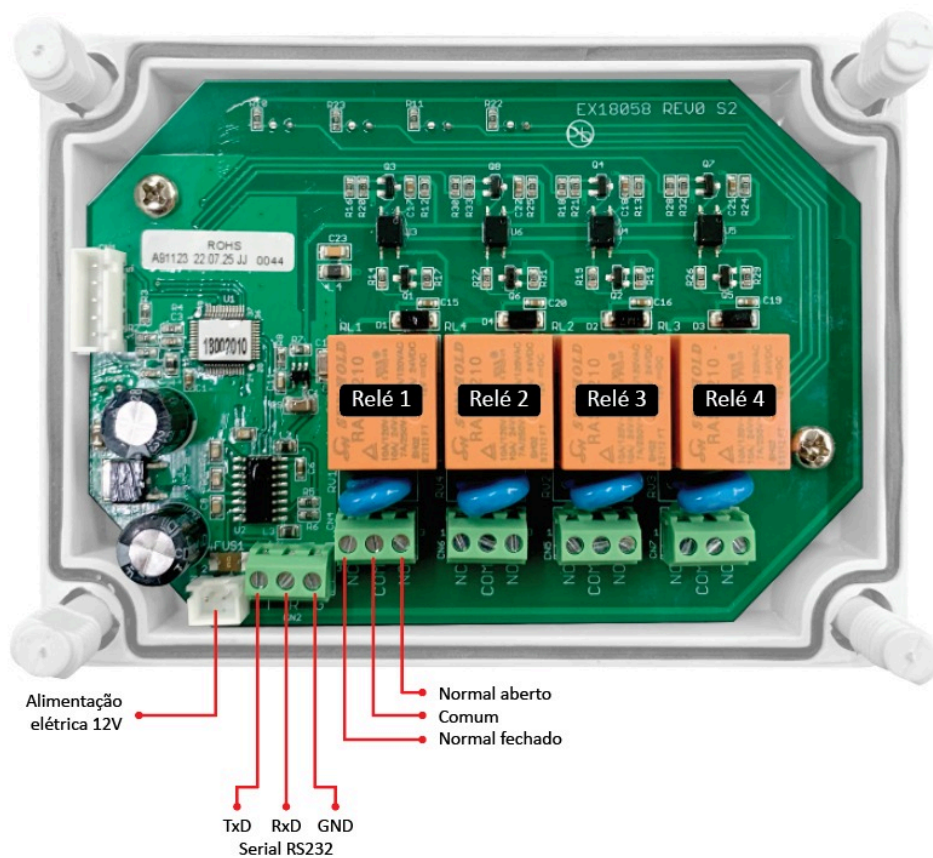

OP-Relay connections.

DIAGRAM LABELS (TRANSLATED):

Relé 1–4 → Relay 1–4 · **Alimentação elétrica 12V** → 12V electrical supply · **Serial RS232 (TxD, RxD, GND)** → Serial RS232 (TxD, RxD, GND) · **Normal aberto** → Normally open (NO) · **Comum** → Common (COM) · **Normal fechado** → Normally closed (NC)

Wiring diagram of the 3-pin SP21 RS232 serial connector:



12 V DC electrical supply	
Pin 1	12 V
Pin 2	0 V
Pin 3	NC

10.10 Digital input

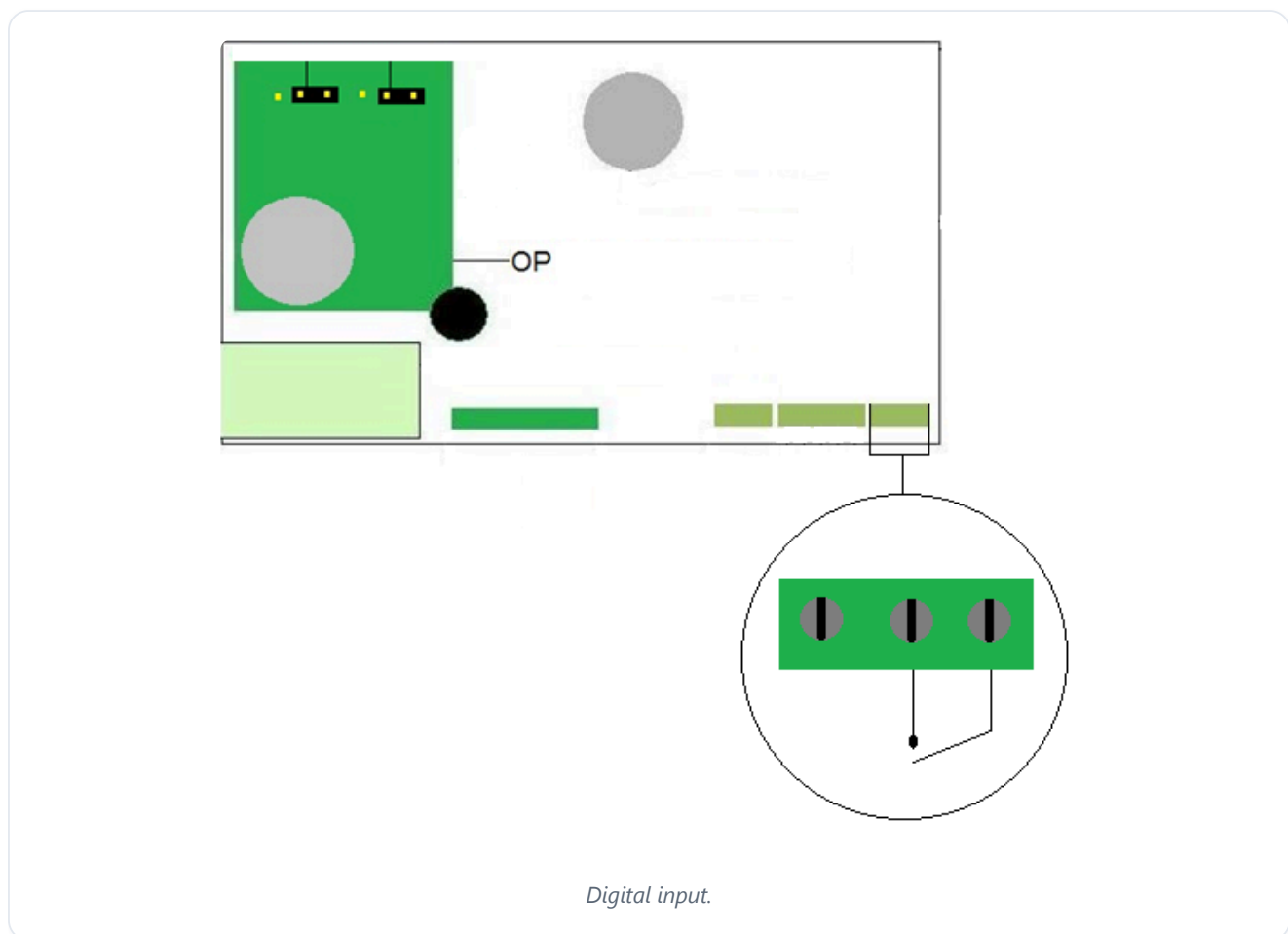
The indicator has a digital input with a programmable function according to the FnC 11 menu.



11 Self-test screens

To access the self-test menu, hold the  key pressed and then turn on the indicator by pressing the  key.

The display will show the following menu:

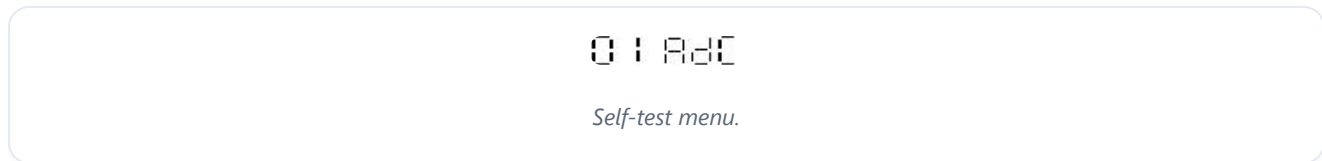

02 EEY — A/D converter test;

03 GEr — Keypad test;

00 E50 — Shows version;



— Exits the self-test menu.

12 Error messages

Code	Meaning
E0	EEPROM is not working correctly, has not been programmed, or the main board is faulty.
E1	Zero is above the zero range at power-up.
E2	Zero is below the zero range at power-up.
E4	Unstable A/D converter (internal value oscillating).
oL	Fault in the A/D circuit. The cell may be connected incorrectly. Overload.
-oL	Fault in the A/D circuit. The cell may be connected incorrectly. Underload.
LoCk	Error in the internal memory. Reconfigure and calibrate the indicator.
oF	The A/D converter value is above the operating range.

13 Appendix

Characters of the 7-segment display

Digito	Display	Alfabeto	Display	Alfabeto	Display
0		A		N	
1		B		O	
2		C		P	
3		D		Q	
4		E		R	
5		F		S	
6		G		T	
7		H		U	
8		I		V	
9		J		W	
		K		X	
		L		Y	
		M		Z	

Representation of characters on the 7-segment display.

14 Weigtech addresses

HEAD OFFICE & DISTRIBUTION CENTRE

Biguaçu, SC
(48) 3112-4299
Rua Edgard Hoffmann, 616
(CICOBI)
CEP 88164-275 – Biguaçu –
SC

TECHNICAL SUPPORT

São Paulo, SP
Av. Jabaquara, 1771 – Sala
201
CEP 04045-003 – São Paulo –
SP

USA AUTONOMOUS UNIT

Davie, FL
(+1) 954-666-0877
10384 W State Rd 84, Ste 6
Davie, FL 33324