

SENSiQ Shear Beam Load Cell VBB / VEB 5 ... 500 kg

- Very high accuracies (up to 6000 parts according to OIML R60)
- Hermetically sealed encapsulation through laser welding (up to IP68)
- Approvals for potentially hazardous areas available: ATEX, IECEx, EAC, USA, Canada
- Optimized by exact calibration for parallel circuits
- Six-wire circuitry
- 100 % stainless steel



Application

VBB-type load cells convert proportionally the mechanical input variable force into the electrical variable voltage.

When used in conjunction with the corresponding VEB elastomer bearings, they are ideal for use in platform scales, dosing scales, and container scales. The compact design facilitates planning into any given construction.

The robustness of the load cells and bearings ensures reliable operation even in harsh environmental conditions.

Construction

The VBB load cells are entirely made of stainless steel and hermetically sealed through laser welding. They are connected electrically by a high-quality, 6-wire screened PVC cable.

The six-wire circuitry makes the measuring signal insensitive to differences in lengths of the connection cables.

Function

- High calibration accuracy which provides ideal conditions for the parallel arrangement of load cells
- High reproducibility of the measuring signals
- Damping of dynamic lateral loads as a result of the elastomer mount
- Self-centering after transverse loading
- Extremely small measured value influence as a result of lateral forces

Dimension

Load cells VBB 5 kg - 0.5 t

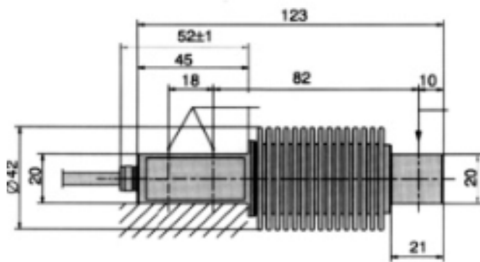

Mounting Load application

Cable 3 m, 6-wire,
shielded,
Shield on casing

Metal bellows

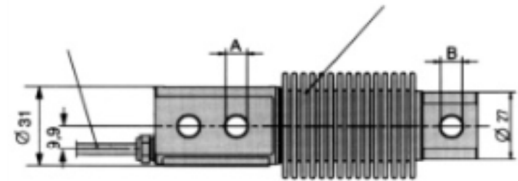

Design	Dimensions A [mm]	Dimensions B [mm]
VBB 5 kg - 0.2 t	8.2	8.2
VBB 0.5 t	10.5	11.1

Elastomer mount VEB 5 kg - 0.5 t for VBB load cells

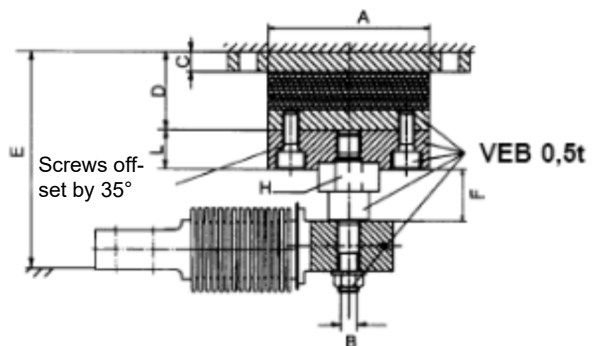
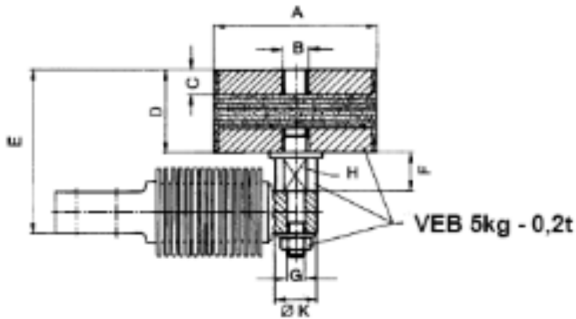

Proper installation position of the elastomer bearing VEB:

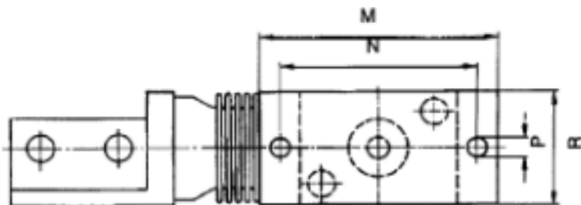

Elastomer mount	A	B	C	D	E	F	G	H	K	L	M	N	P	R	FR*	Smax**
VEB 5 kg - 0.2 t	75	M12	12	40	79 ±1.3	18.5	M8	AWI 17	19	-	-	-	-	-	163	3
VEB 0.5 t	80	M10	10	39	105+2.1/-2.2	26	-	AWI 27	-	20	120	100	9	60	400	4.5

* Restoring force FR in N, at 1 mm lateral displacement

** maximum allowable lateral displacement Smax in mm, at rated load.

Technical Data

Nominal load	E_{max}	5 kg - 0.5 t				-
Accuracy class	-	D1	C3*	C4*	C6***	Ref.
Nominal characteristic value	C_n	2 mV/V +20 μ V/V; -2 μ V/V		2 mV/V \pm 1 μ V/V		-
Compound error	F_{comb}	0.05 %	0.02 %	0.013 %	0.01 %	C_n
Return to zero signal after load (30 min)	F_{dr}	\pm 0.049 %	\pm 0.016 %	\pm 0.012 %	\pm 0.008 %	C_n
Creepage under load (30 min)	F_{cr}	\pm 0.049 %	\pm 0.016 %	\pm 0.012 %	\pm 0.008 %	C_n
Temperature coefficient of the zero signal	TK_0	\pm 0.05 %/10 K	\pm 0.0125 %/10 K	\pm 0.009 %/10 K	\pm 0.009 %/10 K	C_n B B_{tn}
Temperature coefficient of the characteristic value	TK_c	\pm 0.05 %/10 K	\pm 0.008 %/10 K	\pm 0.007 %/10 K	\pm 0.004 %/10 K	C_n B B_{tn}
max. admissible no. of legal-for-trade scale intervals	n_{LC}	1000	3000	4000	6000	-
Smallest scale interval	v_{min}	0.036 %	0.009 %	0.0066 %	0.0066 %	E_{max}
Minimum application range	B_{amin}	36 %	27 %	26 %	39 %	E_{max}
max. application range	B_{amax}	$B_{amax} = E_{max}$				-
Input resistance	R_e	350 Ω - 480 Ω				t_r
Output resistance	R_a	356 Ω \pm 0.2 Ω		356 Ω \pm 0.12 Ω		t_r
Zero Signal	S_0	\pm 1 %				C_n
Max. supply voltage	U_{smax}	18 V				-
Nominal temperature	B_{tn}	-10 $^{\circ}$ C ... +40 $^{\circ}$ C				-
Operating temperature range	B_{tu}	-40 $^{\circ}$ C ... +70 $^{\circ}$ C				-
Operating temperature range explosion-proof design	-	-30 $^{\circ}$ C ... +70 $^{\circ}$ C (ATEX, IECEx, EAC) -30 $^{\circ}$ C ... +40 $^{\circ}$ C (FM-Approval Canada and USA)				-
Reference temperature	t_r	23 $^{\circ}$ C				-
Storage temperature range	B_{ts}	-50 $^{\circ}$ C ... +85 $^{\circ}$ C				-
Limit load	E_L	150 %				C_n
Breaking load	E_D	300 %				C_n
Measuring path **** for nominal load	-	0.25 mm 5 kg	0.3 mm 10 - 100 kg	0.4 mm 200 kg	0.6 mm 500 kg	-
Type of protection	-	IP68 (enhanced test conditions: 1 m water column; 100 h)				-
Type of protection Explosion-proof design	-	IP67				-
Cable specification	-	PVC cable, length 3 m, 6 wires, shielded, shield on casing				-
Connection assignment	-	black: Input- / blue: Input+ / black/yellow: Shield / red: Output- / white: Output+ / gray: Sensor- / green: Sensor+				-
Corrosion protection	-	Stainless steel				-

* Quality C3 is only available for rated loads > 10 kg

** Quality C4 is only available for rated loads > 20 kg

*** Quality C6 is only available for rated loads > 50 kg

**** Overload stops should be set at (measuring range + 0.05 mm) when the scale is unloaded.

Option explosion-proof approvals

	Intrinsically safe explosion-proof design: Option 2GD	Non-intrinsically safe explosion-proof design: Option 2D, 3G
ATEX / IECEx	II 2G Ex ia IIC T4 Gb (Zone 1) II 2D Ex ia IIIC T125°C Db, IP67 (Zone 21)	II 3G Ex ec IIC T4 Gc (Zone 2) II 2D Ex tb IIIC T125 °C Db, IP67 (Zone 21)
FM approval Canada	I / 0 / Ex ia / IIC / T4; -30°C < Ta < 40°C / Ga; 20 / Ex ia / IIIC / T125°C; -30°C < Ta < 40°C / Da; IP67.	not available
FM approval USA	IS / I, II, III / 1 / A, B, C, D, E, F, G / T4; -30°C < Ta < 40°C, I / 0 / AEx ia / IIC / T4; -30°C < Ta < 40°C / Ga; 20 / AEx ia / IIIC / T125°C; -30°C < Ta < 40°C / Da; IP67.	not available
EAC	1Ex ia IIC T4 Gb (Zone 1) Ex ia IIIC T125°C Dc X (Zone 22)	2Ex nA II T4 Gc (Zone 2) Ex tc IIIC T125 °C Dc X (Zone 22)

Load cells marked as intrinsically safe (Ex "i") are operated in an intrinsically safe manner regardless of the zone.

CAUTION! The verification of intrinsically safe circuit must be verified. New barriers are provided in particular for new systems. Verifications of intrinsic safety are available for all load cells and barriers.

Order numbers

Design of load cells	Order number	Ex-design of load cells	Order number option 2GD	Order number option 2D, 3G
VBB 5 kg D1	D 725 417.01	-	-	-
VBB 10 kg D1	D 725 417.02	-	-	-
VBB 10 kg C3	D 725 419.02	VBB 10 kg C3 "Ex"	D 725 419.32	D 725 419.42
VBB 20 kg D1	D 725 417.03	-	-	-
VBB 20 kg C3	D 725 419.03	VBB 20 kg C3 "Ex"	D 725 419.33	D 725 419.43
VBB 50 kg D1	D 725 417.04	-	-	-
VBB 50 kg C3	D 725 419.04	VBB 50 kg C3 "Ex"	D 725 419.34	D 725 419.44
VBB 0.1 t D1	D 725 409.01	VBB 0.1 t D1 "Ex"	D 725 409.61	D 725 409.41
VBB 0.1 t C3	D 725 409.04	VBB 0.1 t C3 "Ex"	D 725 409.64	D 725 409.44
VBB 0.1 t C4	D 726 370.01	VBB 0.1 t C4 "Ex"	D 726 370.31	D 726 370.41
VBB 0.2 t D1	D 725 409.02	VBB 0.2 t D1 "Ex"	D 725 409.62	D 725 409.42
VBB 0.2 t C3	D 725 409.05	VBB 0.2 t C3 "Ex"	D 725 409.65	D 725 409.45
VBB 0.2 t C4	D 726 370.02	VBB 0.2 t C4 "Ex"	D 726 370.32	D 726 370.42
VBB 0.2 t C6	D 726 370.04	VBB 0.2 t C6 "Ex"	D 726 370.34	D 726 370.44
VBB 0.5 t D1	D 725 409.03	VBB 0.5 t D1 "Ex"	D 725 409.63	D 725 409.43
VBB 0.5 t C3	D 725 409.06	VBB 0.5 t C3 "Ex"	D 725 409.66	D 725 409.46
VBB 0.5 t C4	D 726 370.03	VBB 0.5 t C4 "Ex"	D 726 370.33	D 726 370.43

Elastomer mount description	Order number	Elastomer mount description	Order number
VEB 5 kg - 0.2 t	D 725 408.01	VEB 0.5 t	D 725 408.02

Order example:

Rated load 0.2 t, Precision class C6: Typ VBB 0.2 t C6 – Order number D 726 370.04

Other models on request.

