



Quick Start Guide

Welcome to the BirdReel Flock!

This helpful guide will get you up and flying in no time.

If you need help, we're just a 'chirp' away.

Call us at 1-833-459-7770 OR email us at

support@birdreel.com

PRO TIPS

1. **Make sure the camera has been fully charged for the first time.**
2. **Do not expose the camera lens to direct sunlight.**
3. **Do not soak the bird feeder in water.**
4. **Use 2.4 GHz WI-FI to connect the application.**
5. **Stay away from strong light when pairing.**
6. **Keep the bird feeder within the range of WI-FI signal.**

WHAT'S IN THE BOX



Bird feeder

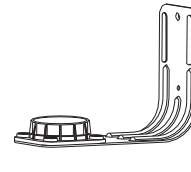

Bird feeder bracket

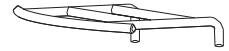

Perch



Drill Sticker

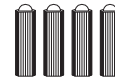
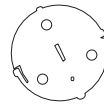

SPECIFICATIONS

Product Model	BF11
Charging	Solar panel and USB cable
Battery	5200 mAh Rechargeable Lithium-Ion Battery
Resolution	2.0 MegaPixels Photos and 1080P HD Live Stream Video
Operating Temperature	-5°F to 120°F (-20.5°C to 48.5°C)
Wireless Type	WiFi 2.4GHz
Field of View	Diagonal: 130°, Horizontal: 94°, Vertical: 40°
Dimension	L7.64 * W8.46 * H12.40 inches (19.4 * 21.5 * 31.5cm)
Power Supply	DC 5V2A
Power Consumption	2W (Max)
Battery Life	4-6 years
Night Visual Range	8m (Max)
Anti-flicker	50HZ /60HZ
SOLAR PANEL SPECIFICATION	
IPCE	19%
Working Voltage (Vmp)	5V±5%
Working Current (Imp)	400mA±5%
Open Circuit Voltage (VOC)	7.2V±5%
Short-Circuit Current (ISC)	480mA±5%

BIRDREEL COMPONENTS

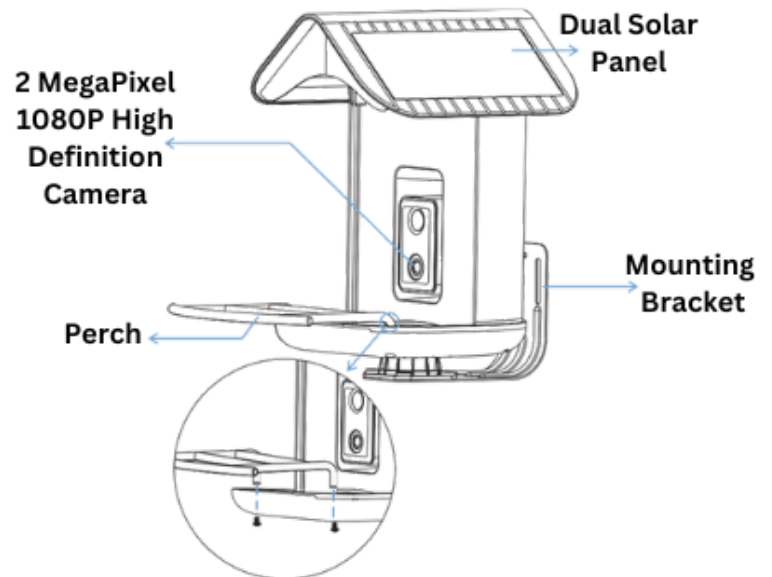

CAMERA COMPONENTS

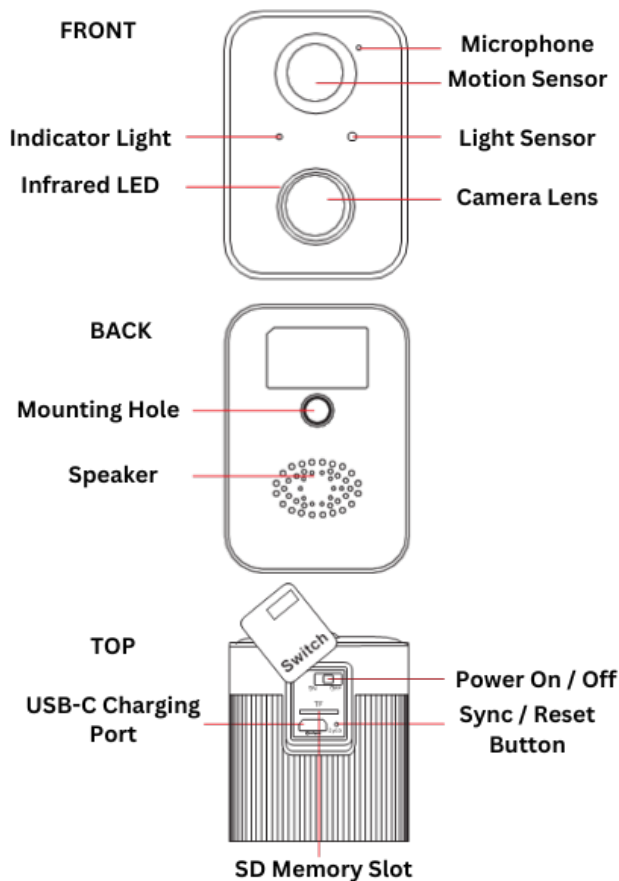

INDICATOR LIGHT STATUSES

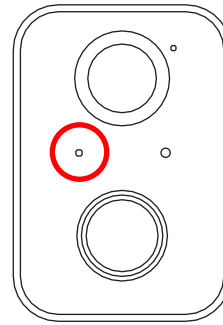

1. Camera powering up: Red light always ON.
2. Pairing mode: Red light fast blinking.
3. Network connecting: Green light fast blinking.
4. Network connected: Green light always ON.
5. Abnormal status: Red light slow blinking – Use the Reset button
6. During firmware update: Yellow light always ON.
7. Charging status: White light is ON during charging and OFF after fully charged

SETUP THE BIRD LOVER APP

Download or scan the QR code and install the Bird Lover



App for either IOS or Android. Once downloaded, the app will prompt you to register your device. Enter your phone number or email address and select the country. You will receive the registration code. Input the registration code, then create a password.

BIRDREEL APP OVERVIEW

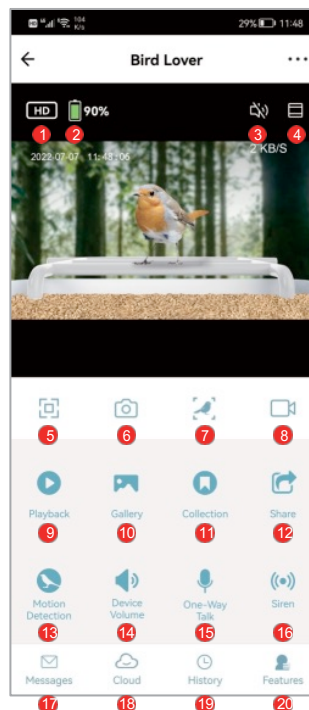

1. Quality adjustment: HD or SD
2. Battery Charge Level
3. Voice switch
4. Zoom in on the camera screen
5. Change to landscape or portrait viewing mode
6. Take a photo and store to the Gallery
7. Detect the bird in the video using AI recognition
8. Take a video and store in the Gallery
9. Playback from previous motion detections
10. View photos or videos taken
11. Check out the bird collection
12. Share the device with friends and family
13. Motion detection (Click to turn on/off)
14. Change Device Volume for Speaker or Siren
15. One-Way Talk or Two-Way Talk activation
16. Turn the Siren on or off
17. View Messages from motion detection
18. Manage or activate the Cloud storage service
19. View the History of AI bird recognition
20. View all menu features

CONNECT BIRDREEL TO BIRD LOVER MOBILE APP AND HOME WIFI

1. Turn on the Power

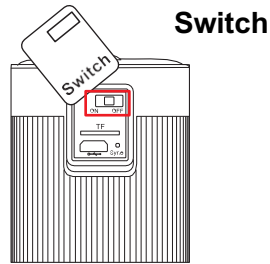

3. Enter the Wifi Password

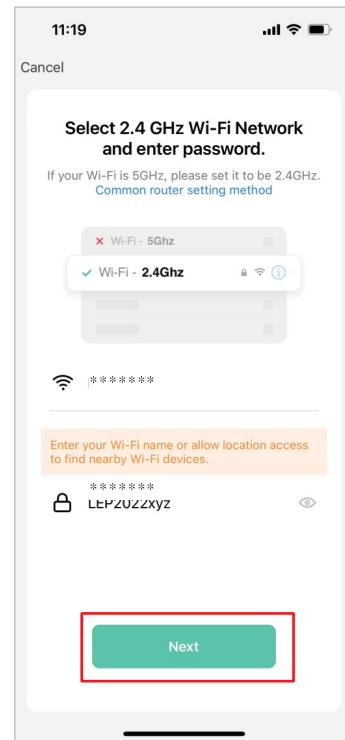

2. Open the APP and connect according to the following steps.

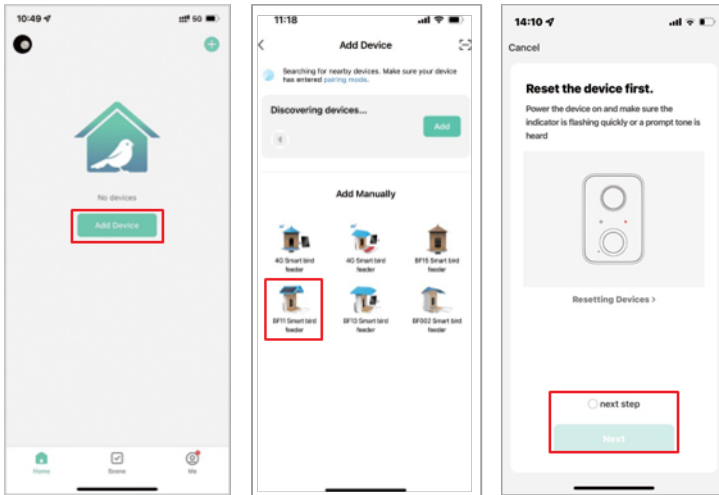

4. Scan the QR code with the feeder camera and select the button on your phone when you hear the sound of the camera prompt.

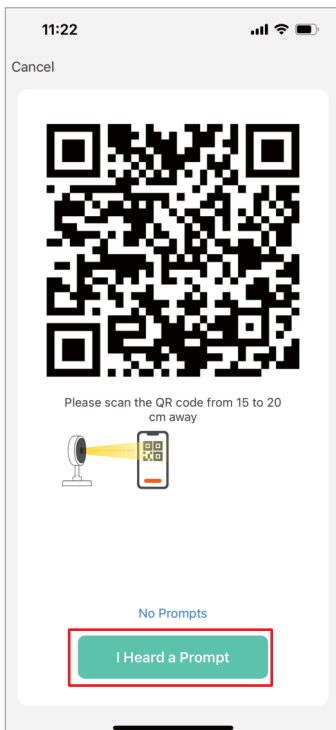

NOTE:

Aim the QR Code at the camera until you hear the three beeps.

5. Wait for the connection to complete - click "Done".

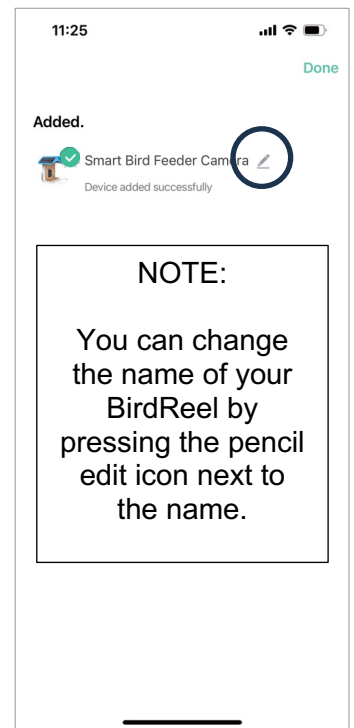
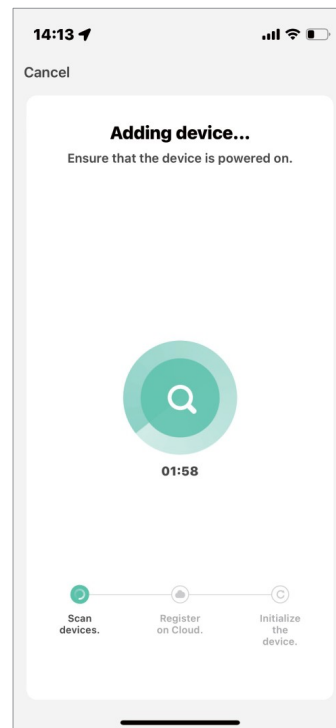

NOTE:

You can change the name of your BirdReel by pressing the pencil edit icon next to the name.

TOP COVER INSTALLATION

1. Align the top cover with the groove in the hopper and press down.

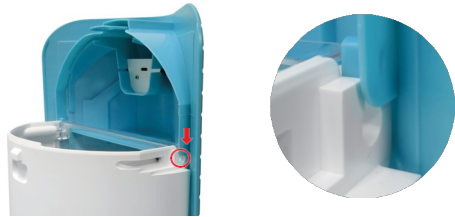

2. Connect the battery cable to the top



3. Twist and snap the top cover.



HOW TO INSTALL THE MOUNTING BRACKET

1. Use the provided template to drill pilot holes



2. Insert the green plastic screw spacer into the hole



3. Fix the bracket with the LONG screws



4: Align the bird feeder and the three holes underneath and fix the feeder with the three SHORT screws



6. Install the perch with the included screws



Frequently Asked Questions

Q: Do I need to create an account to use the Bird Lover Companion App?

A: Yes, you are required to register for an account through the app using your email address or phone number to get a verification code. There is no fee for using the app.

Q: Which operating systems are compatible with the app?

A: The app is compatible with Apple iOS (iOS 10.0 and above) and Android (v5.0 and above) systems.

Q: What Wi-Fi band does the AI Camera support?

A: The AI Camera supports the 2.4Ghz Wi-Fi band.

Q: Can I link multiple accounts to one Bird Reel Smart Bird Feeder?

A: No, only one account can be linked to the Bird Reel Smart Bird Feeder at a time. If you want to link another account, you must un-link the existing account by pressing and holding the reset button for 10 seconds and then re-pair it.

Q: Can I share the Bird Reel Smart Bird Feeder with other users?

A: Yes, you can share the device with other users who have installed the "Bird Lover" app. Here are the two methods for sharing the device:

- By adding their account names to share the device.
- By adding new accounts to your family group.

Q: What is the language of the app?

A: The language of the app will match your device's system language, while the language of AI recognition result currently only supports English and Chinese.

Q: Why is the camera battery draining so fast?

A: While the camera's low power consumption gets charged continually by the solar panel during daylight hours, the battery may drain faster due to the following reasons:

- Continual live-streaming from the Bird Lover app will drain the battery faster over time.
- Very active bird feeders will trigger the motion detection system and consume more battery over time. To reduce the consumption, you can modify your motion detection settings in the application to increase the time between detection events.
- If the Wi-Fi performance near the feeder is weak, the camera will repeatedly search for signal until its battery power is drained. Check the Wi-Fi signal strength indication in the Device Settings page to ensure a strong signal.

Q: Why is the "Playback" option not available?

A: If you can't access the playback option, ensure the following:

- Confirm that the SD Memory card is installed correctly OR, if you're subscribed to the cloud storage, ensure the subscription is current.
- If the SD card cannot be read, format it to FAT32 through the Bird Lover app or computer. The product supports 4G up to a 128G SD card.
- Make sure you have enabled recording in the "Recording Settings" and have turned the motion detection mode on.

Q: How do I turn message notifications on or off?

A: You can configure your account to receive notifications as well as turn each device on or off for notifications. Here's how:

- Click the "Me" option at the bottom left of Main Menu and then the Gear icon in the upper right-hand corner.
- Turn on or off the "Device Alert" and set a Do Not Disturb schedule (optional).
- Then turn on off System Notification and set the Recurring window (this will prevent multiple alerts from occurring within a short time frame).
- Turn on or off the "Motion Detection" or "Bird Spotting" from the Main Menu (Red means activated).
- Turn on or off the "Detection Alarm Settings" in the Settings menu.

Q: Why is the bird recognition result incorrect?

A: The accuracy of the bird recognition result depends on the angle and clarity of the bird image. For a more accurate result:

- Ensure the picture is clear and bright by adjusting the position of the Bird Reel feeder to align with the sun.
- Make sure the identification features of the bird (head, tail, wings, and pattern of feathers) are not obscured.
- The bird should be close to the center of the picture and unobstructed.
- If the first result is not successful, try again to capture a clearer photo while the bird is present.
- If there are two or more bird species in one picture, the result will focus on the bird in the closest and/or most centered position.

Q: What should I do if my Bird Reel is not working properly?

A: Here are the steps:

- Check whether the power cable is correctly plugged in from the solar panels to the camera.
- Ensure the power switch is turned on.
- Check whether Wi-Fi is connected, and the Bird Reel is in range of the Wi-Fi signal.
- Press the Reset button on the camera using the reset pin included with your BirdReel. Then go back through the Add Device process to re-connect the camera to your Wi-Fi.



Web: www.birdreel.com
Phone: 1-833-459-7770
Email: support@birdreel.com