

# Switch-Pak™

w/ Compact Junction Box



## AU18, AV16 & AZ18 Series Owner's Manual



Length:	6" to 10' (15 cm to 3m)
Switch point:	1 (set by factory)
Orientation:	± 20° vertical
Process temp.:	F: -40° to 176° C: -40° to 80°
Pressure:	AU1_: 150 psi (10 bar) AZ1_: 150 psi (10 bar) AV1_: 25 psi (1.7 bar)
Wetted material:	424_: PP 524_: PVDF Kynar®
Process mount:	_243: 2" NPT _247: 1 1/2" G
Enclosure rating:	NEMA 4X (IP65)
Installed height:	3.6" (9.1 cm) above tank
process mount	
Encl. material:	PP, UL94VO
Conduit entrance:	Single, 1/2" NPT
Termination:	2-4 poles
CE compliance:	EN 50082-2 immunity EN 55011 emission EN 61010-1 safety

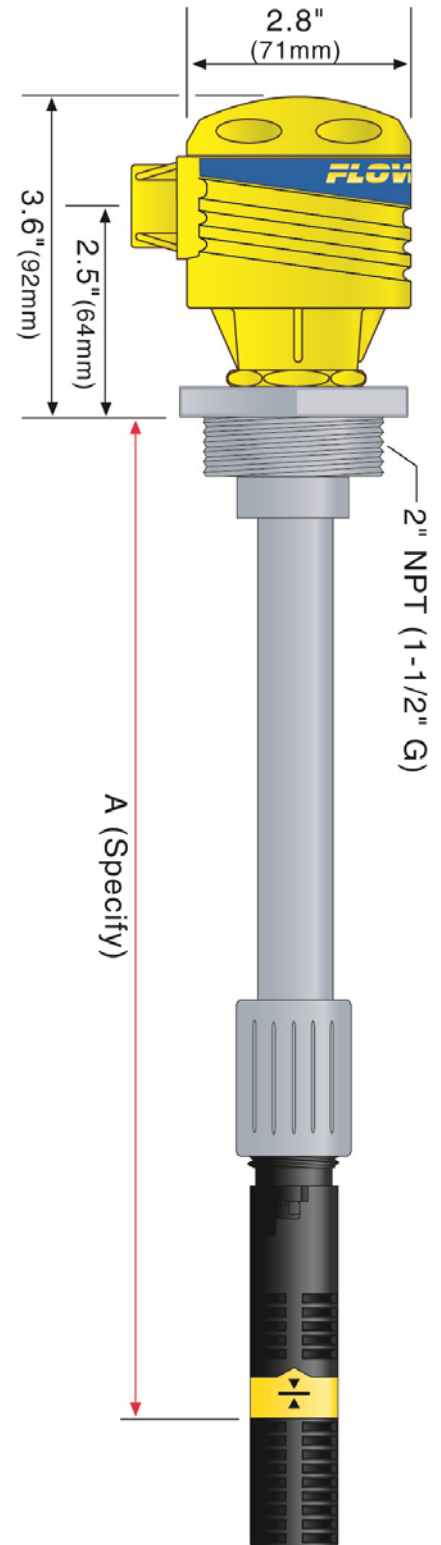

**SENSOR TECHNOLOGIES:**

**Ultrasonic (LU10 series)**

Broadly applied in chemical, solvent, hydrocarbon and light weight oil media

Supply voltage:	12-36 VDC
Consumption:	25 mA maximum
Contact type:	(1) SPST relay
Contact rating:	GP: 120 VAC/VDC @ 1A IS: 32 VDC @ 0.5A
Contact output:	Selectable NO/NC
Classification:	Intrinsically safe



**Buoyancy (LV10 series)**

Best applied in clean water or water-like chemical media that is non-coating or scaling

Contact type:	(1) SPDT reed
Contact rating:	120 VAC/VDC @ 15 VA
Contact output:	Selectable NO/NC
Classification:	General purpose



**Vibration (LZ12 series)**

Typically applied in wastewater media with light coating and/or foaming characteristics

Supply voltage:	12-30 VDC
Consumption:	25 mA maximum
Contact type:	(1) SPST relay
Contact rating:	120 VAC/VDC @ 1A
Contact output:	Selectable NO/NC
Classification:	General purpose



**ONE SENSOR CONFIGURATION:**  
(AU18-\_24\_, AV16-\_24\_ or AZ18-\_24\_)

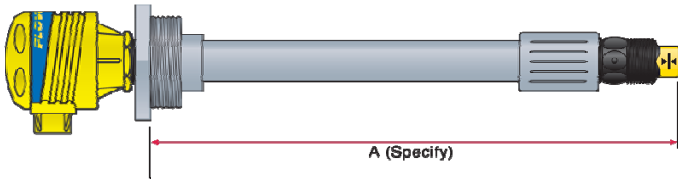

<p><b>Ultrasonic</b>  <b>AU18-4243</b>                  1 x LU10-1305                  1 x LM45-1001                  1 x LC06-1001</p> <p><b>AU18-4247</b>                  1 x LU10-1325                  1 x LM45-1061                  1 x LC06-1051</p> <p><b>AU18-5243</b>                  1 x LU10-2305                  1 x LM45-5001                  1 x LC06-1001</p> <p><b>AU18-5247</b>                  1 x LU10-2325                  1 x LM45-5061                  1 x LC06-1051</p>	<p><b>Buoyancy</b>  <b>AV16-4243</b>                  1 x LV10-1301                  1 x LM45-1001                  1 x LC06-1001</p> <p><b>AV16-4247</b>                  1 x LV10-1351                  1 x LM45-1061                  1 x LC06-1051</p> <p><b>AV16-5243</b>                  1 x LV10-5301                  1 x LM45-5001                  1 x LC06-1001</p> <p><b>AV16-5247</b>                  1 x LV10-5351                  1 x LM45-5061                  1 x LC06-1051</p>	<p><b>Vibration</b>  <b>AZ18-4243</b>                  1 x LZ12-1405                  1 x LM45-1001                  1 x LC06-1001</p> <p><b>AZ18-4247</b>                  1 x LZ12-1425                  1 x LM45-1061                  1 x LC06-1051</p>
--	--	---

**COMPONENT LIST:**

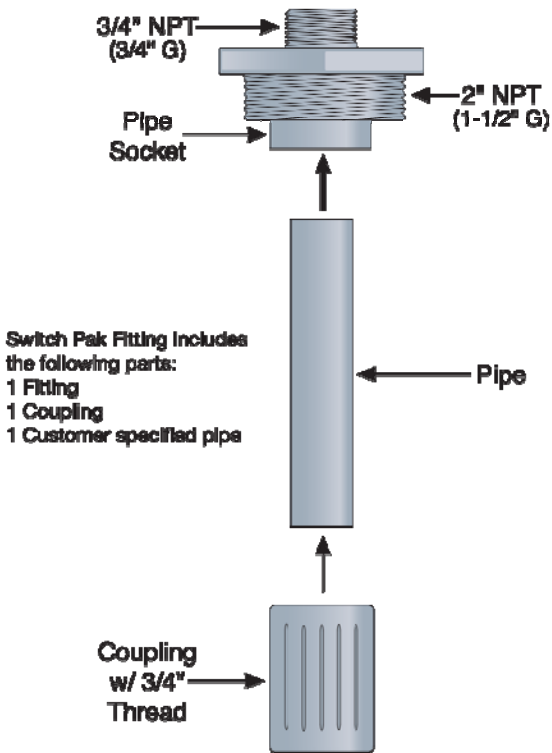

**Switch-Pak™ Fitting**  
 P/N: LM45-1001, LM45-1061,  
 LM45-5001 or LM45-5061

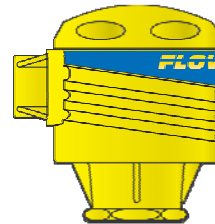

**Compact Relay Controller**  
 P/N: LC06-1001 or LC06-1051



**Switch-Tek Level Switch**  
 P/N: LU10-1305, LU10-1325,  
 LU10-2305, LU10-2325,  
 LV10-1301, LV10-1351,  
 LV10-5301, LV10-5351,  
 LZ12-1405 or LZ12-1425

**⚠ About this Manual:** PLEASE READ THE ENTIRE MANUAL PRIOR TO INSTALLING OR USING THIS PRODUCT. This manual includes information on the Switch-Pak™ with Compact Relay Controller: AU15-\_24\_, AZ18-\_24\_ and AV16-\_24\_. The units are identical except for the material of construction and the sensors technology.

**⚠ User's Responsibility for Safety:** Flowline manufactures a wide range of liquid level sensors, controllers, and mounting systems. It is the user's responsibility to select components that are appropriate for the application, install them properly, perform tests of the installed system, and maintain all components. The failure to do so could result in property damage or serious injury.

**⚠ Proper Installation and Handling:** Use a proper sealant with all installations. Never overtighten the components. Always check for leaks prior to system start-up.

**⚠ Material Compatibility:**

Polypropylene (PP, a polyolefin): Sensor, Switch-Pak™ fitting, Controller Housing.

Polyvinylidene Fluoride (PVDF): Sensor and Switch-Pak™ fitting.

Viton (a fluorocarbon): O-ring.

Make sure that the application liquids are compatible with the materials that will be wetted. To determine the chemical compatibility between the components and its application liquids, refer to the Compass Corrosion Guide, available from Compass Publications.

**⚠ Temperature and Pressure:** Switch-Pak™ is designed for use in application temperatures up to 80° C (176° F). The Vibration and Ultrasonic packages are designed for pressurized applications up to 150 psi (10 bar) and the Buoyancy package is designed for use up to 25 psi (1.7 bar).

**⚠ Wiring and Electrical:** Electrical wiring of any liquid level control system should be performed in accordance with all applicable national, state, and local codes. Take care not to cut or break the outer insulation jacket of wiring that may be immersed while routing cables in the Switch-Pak™ system. Such breaks of the liquid seal of the sensor system may lead to component failure.

**⚠ Flammable, Explosive and Hazardous Applications:** Switch-Pak™ may be used within flammable or explosive applications only if the associated components are rated intrinsically safe for such use. In hazardous applications, use redundant measurement and control points, each having a different sensing technology.

**⚠ Make a Fail-Safe System:** Design a fail-safe system that accommodates the possibility of system or power failure. In critical applications, Flowline recommends the use of redundant backup systems and alarms in addition to the primary system.

**About Switch-Pak™:** Flowline's Switch-Pak™ with Compact Junction Box Assembly is an single-point mounting system for installing one level sensor vertically within a tank. The compact junction box features termination for the various wires from each level switch as well as a 1/2" conduit connection. Switch-Pak™ mounts vertically through a standard 2" NPT tank adapter, or on a side mount bracket (such as the LM50-1001).

**Level Switches:** Switch-Pak™ includes a single level switch used to identify it's own unique wet / dry condition. The technologies used to indicate level are either Ultrasonic, Buoyancy or Vibration. Each technology features a unique wiring/power configuration (Ultrasonic requires 12-36 VDC power for operation and Vibration require 12 to 30 VDC power for operation, see below). The switch is terminated in the Compact Junction Box. The Compact Junction Box provides a 1/2" Conduit connection and 6 poles for wire termination.



**Compact Junction Box**  
(inside shown)

### VIBRATION (LZ12-1405) WIRE CONFIGURATION:

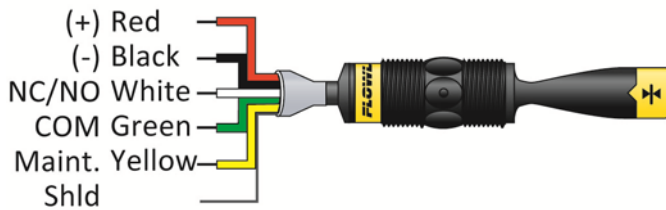

### ULTRASONIC (LU10-\_305 OR LU10-\_325) WIRE CONFIGURATION:

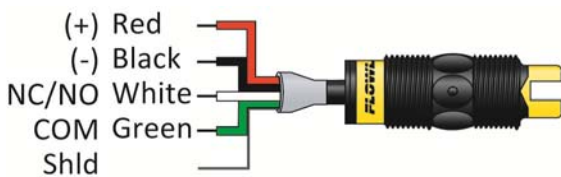

### BUOYANCY (LV10-\_301 OR LV10-\_351) WIRE CONFIGURATION

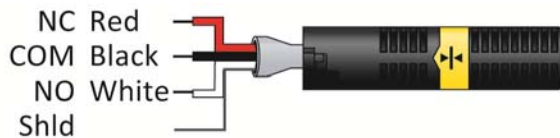

**Compact Junction Box**  
(inside shown)

**SWITCH-PAK™, IN-TANK INSTALLATION:**

Flowline's Switch-Pak™ mounting system is an in-tank fitting, which enables users to install any technology, along the entire length of track. Switch-Pak™ may be installed thru the top wall of any tank or flange, using a standard 2" NPT tank adapter or blind flange. If tank top is not available, Flowline's side mount bracket, LM50-1001, enables Switch-Pak™ to be installed directly to the side wall or lip of the tank.

**TANK ADAPTER:**

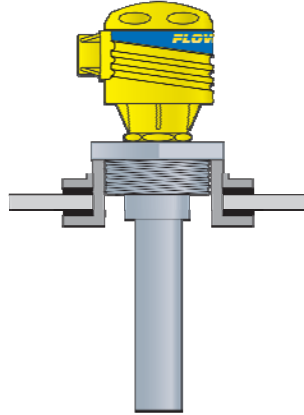

**FLANGE MOUNTING:**

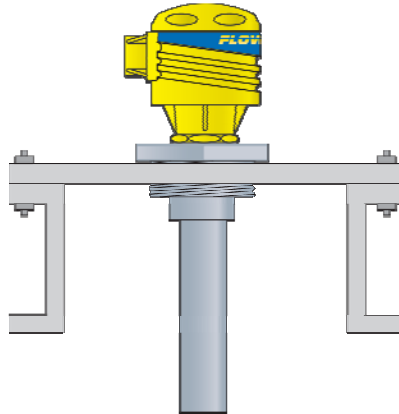

**SIDE MOUNT BRACKET:**

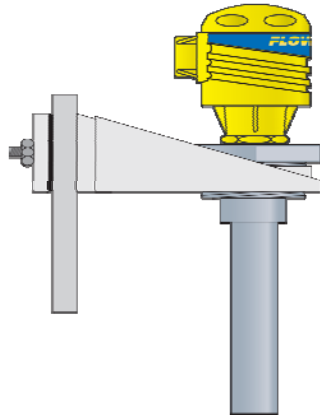

**LIP OF TANK**

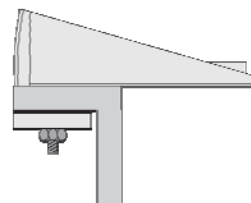

**SIDE-WALL**

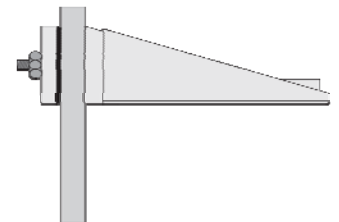

**ULTRASONIC AND VIBRATION SWITCHES**

**(LU10-1305, LU10-1325, LZ12-1405, LZ12-1425):**

The LU10-13\_5 and LZ12-14\_5 switch can be wired normally open or normally closed for your application requirement. Each ultrasonic switch requires 12 - 36 VDC power while each vibration switch requires 12-30 VDC power to operate the sensor and switch the relay. The relay output can be wired as a dry contact. All illustrations below identify a Dry switch state as the normal position of the relay.

**SWITCHING A NORMALLY OPEN DC LOAD:**

The Red wire connects to Positive (+) of the power supply and the Black wire connects to Negative (-). The LOAD can be attached to either the Green or White wires. Complete the circuit by either connecting the Green to (+) VDC power or White to (-) VDC power (see illustration below).

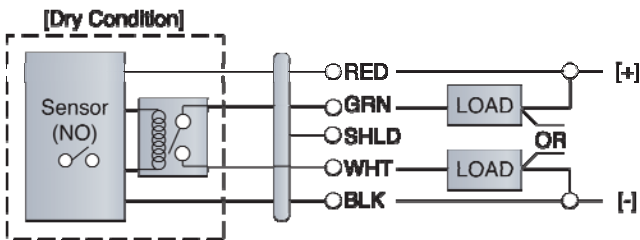

**SWITCHING A NORMALLY CLOSED DC LOAD:**

The Black wire connects to Positive (+) of the power supply and the Red wire connects to Negative (-). The LOAD can be attached to either the Green or White wires. Complete the circuit by either connecting the Green to (+) VDC power or White to (-) VDC power (see illustration below).

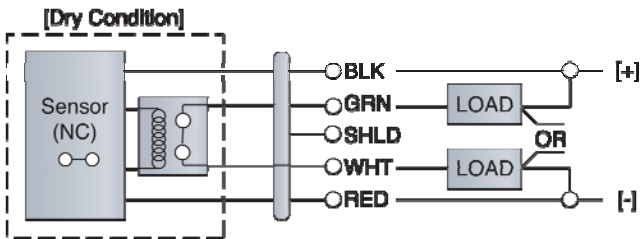

**MAINTENANCE ALARM (LZ12 VIBRATION ONLY):**

For optimum performance and proactive maintenance, the sensor automatically adjusts for coating, and if necessary, outputs a preventative maintenance alarm. The Yellow wire is a NPN transistor designed to switch when a build-up of material prevents the vibration switch from operating at its operational frequency. Use the Yellow wire to identify when the Vibration switch requires cleaning (see the LZ12 manual for wiring information).

## BUOYANCY LEVEL SWITCH (LV10-1301 & LV10-1351):

The LV10-13\_1 switch can be wired normally open or normally closed for your application requirement.

### NORMALLY OPEN:

Use the Black and White wires for operating the LV10-\_3\_1 in a normally open state. Normally open is defined as the switch being open when the float is dry and closed when the float becomes submersed. This operation is typical for indicating a high level.

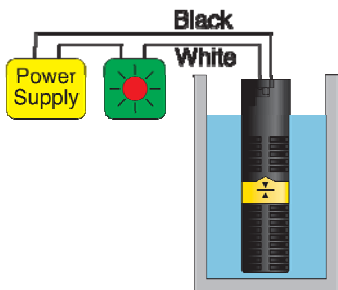
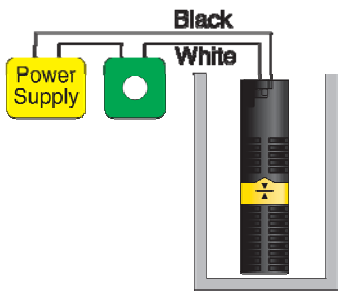

### NORMALLY CLOSED:

Use the Black and Red wires for operating the LV10-\_3\_1 in a normally closed state. Normally closed is defined as the switch being closed when the float is dry and open when the float becomes submersed. This operation is typical for indicating a low level.

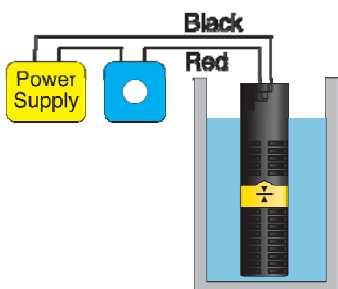
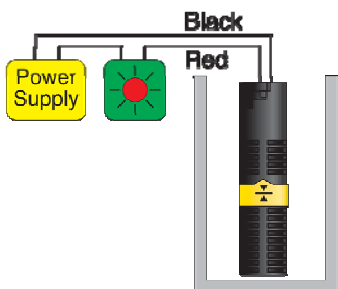

**General:** The Switch-Pak™ with Compact Junction Box requires no periodic maintenance except cleaning as required. It is the responsibility of the user to determine the appropriate maintenance schedule, based on the specific characteristics of the application liquids.

**CLEANING PROCEDURE:**

1. **Power:** Make Sure that all power to the sensor, controller and/or power supply is completely disconnected.
2. **Sensor Removal:** Make sure that the tank is in a state where it is safe to remove the sensors. Carefully, remove the Switch-Pak™ from the installation.
3. **Cleaning the Sensor:** Use a soft bristle brush and mild detergent, carefully wash the Switch-Pak™. Do not use harsh abrasives such as steel wool or sandpaper, which might damage the surface sensor. Do not use incompatible solvents which may damage the sensor's PP or Ryton plastic body.
4. **Sensor Installation:** Follow the appropriate steps of installation as outlined in the installation section of this manual.

**TESTING THE INSTALLATION:**

1. **Power:** Turn on power to the switches and/or power supply.
2. **Immersing the switch:** Immerse the sensing tip of each switch in its application liquid, by filling the tank up to the switches point of actuation. An alternate method of immersing the switch during preliminary testing is to hold a cup filled with application liquid up to the switch's tip.
3. **Test:** With the switch being fluctuated between wet and dry states, the switch will open or close depending on wiring status. If the system doesn't have an input indicator, use a multimeter to ensure that the switch produces the correct signal.

**CURRENT TEST (ULTRASONIC AND VIBRATION ONLY):**

Used to verify if the sensor is indicating a wet or dry condition. This test uses only two wires (Red and Black). The sensor draws 5 mA (ultrasonic) or 8 mA (vibration) when it is dry, and 19 mA when wet.

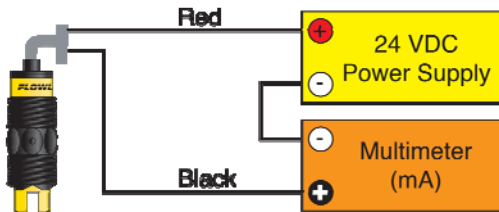

**CONTACT TEST (BUOYANCY ONLY):**

Used to verify if the reed switch is switching between dry (open) and wet (closed). Check for continuity across Black and White (open for dry and closed for wet). Checking across Black and Red will result in a closed when dry and open when wet condition.

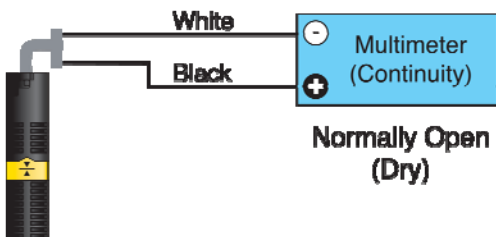

### WARRANTY

Flowline warrants to the original purchaser of its products that such products will be free from defects in material and workmanship under normal use and service in accordance with instructions furnished by Flowline for a period of two years from the date of manufacture of such products. Flowline's obligation under this warranty is solely and exclusively limited to the repair or replacement, at Flowline's option, of the products or components, which Flowline's examination determines to its satisfaction to be defective in material or workmanship within the warranty period. Flowline must be notified pursuant to the instructions below of any claim under this warranty within thirty (30) days of any claimed lack of conformity of the product. Any product repaired under this warranty will be warranted only for the remainder of the original warranty period. Any product provided as a replacement under this warranty will be warranted for the full two years from the date of manufacture.

### RETURNS

Products cannot be returned to Flowline without Flowline's prior authorization. To return a product that is thought to be defective, go to [www.flowline.com](http://www.flowline.com), and submit a customer return (MRA) request form and follow the instructions therein. All warranty and non-warranty product returns to Flowline must be shipped prepaid and insured. Flowline will not be responsible for any products lost or damaged in shipment.

### LIMITATIONS

This warranty does not apply to products which: 1) are beyond the warranty period or are products for which the original purchaser does not follow the warranty procedures outlined above; 2) have been subjected to electrical, mechanical or chemical damage due to improper, accidental or negligent use; 3) have been modified or altered; 4) anyone other than service personnel authorized by Flowline have attempted to repair; 5) have been involved in accidents or natural disasters; or 6) are damaged during return shipment to Flowline. Flowline reserves the right to unilaterally waive this warranty and dispose of any product returned to Flowline where: 1) there is evidence of a potentially hazardous material present with the product; or 2) the product has remained unclaimed at Flowline for more than 30 days after Flowline has dutifully requested disposition. This warranty contains the sole express warranty made by Flowline in connection with its products. **ALL IMPLIED WARRANTIES, INCLUDING WITHOUT LIMITATION, THE WARRANTIES OF MERCHANTABILITY AND FITNESS FOR A PARTICULAR PURPOSE, ARE EXPRESSLY DISCLAIMED.** The remedies of repair or replacement as stated above are the exclusive remedies for the breach of this warranty. **IN NO EVENT SHALL FLOWLINE BE LIABLE FOR ANY INCIDENTAL OR CONSEQUENTIAL DAMAGES OF ANY KIND INCLUDING PERSONAL OR REAL PROPERTY OR FOR INJURY TO ANY PERSON. THIS WARRANTY CONSTITUTES THE FINAL, COMPLETE AND EXCLUSIVE STATEMENT OF WARRANTY TERMS AND NO PERSON IS AUTHORIZED TO MAKE ANY OTHER WARRANTIES OR REPRESENTATIONS ON BEHALF OF FLOWLINE.** This warranty will be interpreted pursuant to the laws of the State of California. If any portion of this warranty is held to be invalid or unenforceable for any reason, such finding will not invalidate any other provision of this warranty.

For complete product documentation, video training, and technical support, go to [www.flowline.com](http://www.flowline.com).

For phone support, call 562-598-3015 from 8am to 5pm PST, Mon - Fri.

(Please make sure you have the Part and Serial number available.)