



PETROLEUM 8

2" x 2" Self Priming Centrifugal Pump

Model PE Pumps - Compatible For Ethanol & E 85

Petroleum 8 self-priming centrifugal pumps are capable of creating vacuum sufficient to lift liquids from heights up to 25 feet above the source. To handle many different fuels, the Petroleum 8 is available in three distinct models: PO, PG and PE 8.

A Petroleum 8 PumPAK® is a fully assembled and run tested pump end that can be easily coupled to a number of drivers such as hydraulic motors, 56C and 145TC frame motors and gas engines. A bearing pedestal is also available for T-frame motor or belt drive.

Standard features include SS drive sleeve, SS fasteners, renewable wear plate, and a semi-open dynamically balanced impeller.

The Petroleum 8 Pump is available in three distinct models: PG, PO and PE

Model PG Pumps - Compatible For Gasoline, Kerosene, Avgas & Jet Fuel

Model PO Pumps - Compatible For BioDiesel, Fuel Oil & Diesel

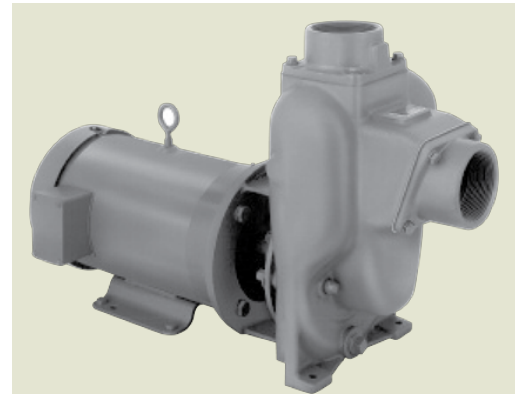

Application

- Agricultural
- Industrial
- Marine
- OEM

Features

- Gas engine for diesel fuel transfer
- Non-spark clamp (on some models)
- Renewable wear plate
- Stainless steel drive sleeve
- Stainless steel fasteners
- Up to a 25' suction lift

SPECIFICATIONS:

Suction And Discharge	2" x 2" NPT
Flow	Up to 150 GPM
Head Feet	UP to 100'
Impeller	PE- semi-open cast iron, 316 SS (optional), PG- 8- semi-open cast iron, aluminum (optional), PO 8- semi-open cast iron
Motor	Up to 3 HP
Drive Options	Close coupled 56C, Engine mount 5.5 HP, Engine mount 6.5 HP, Hydraulic motor .22 cu. in., Hydraulic motor .37 cu. in., Hydraulic motor .45 cu. in., Close coupled 145TC, Pedestal, PumPAK® (without motor)
Mounting Options	PE 8 - explosion proof, class 1, group D, PG 8 - explosion proof, class 1, group D, PO 8 - TEFC
Options	5 blade impeller available for higher flows
Compatible For	PE 8 - ethanol, E 85, PG 8 - gasoline, avgas, kerosene, jet A/8, PO 8 - biodiesel, fuel oil, diesel

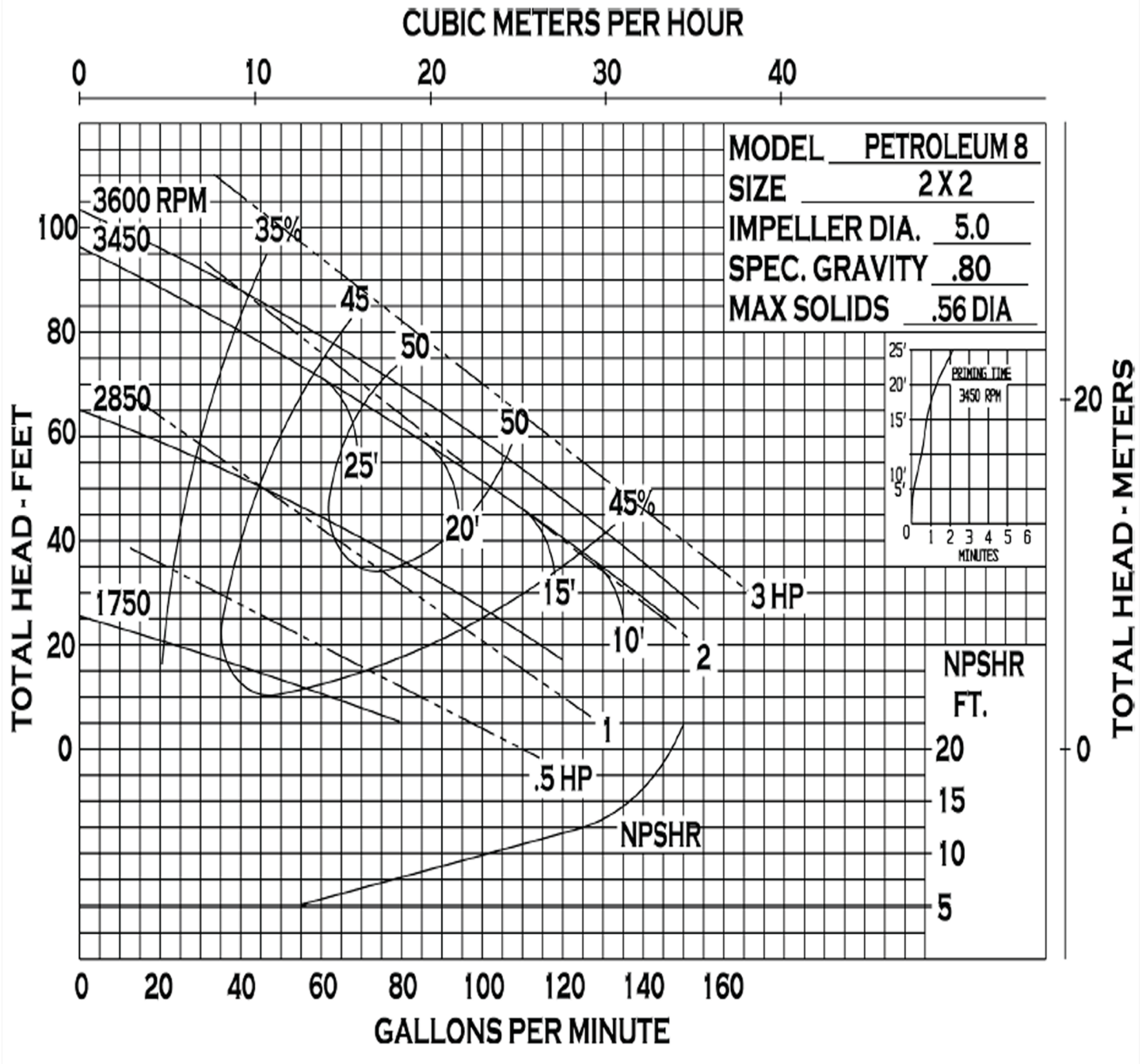

34800 BENNETT - FRASER, MI 48026-1686
 (586) 293-8240 - FAX (586) 293-8469
 (800) 563-8006 - www.mppumps.com

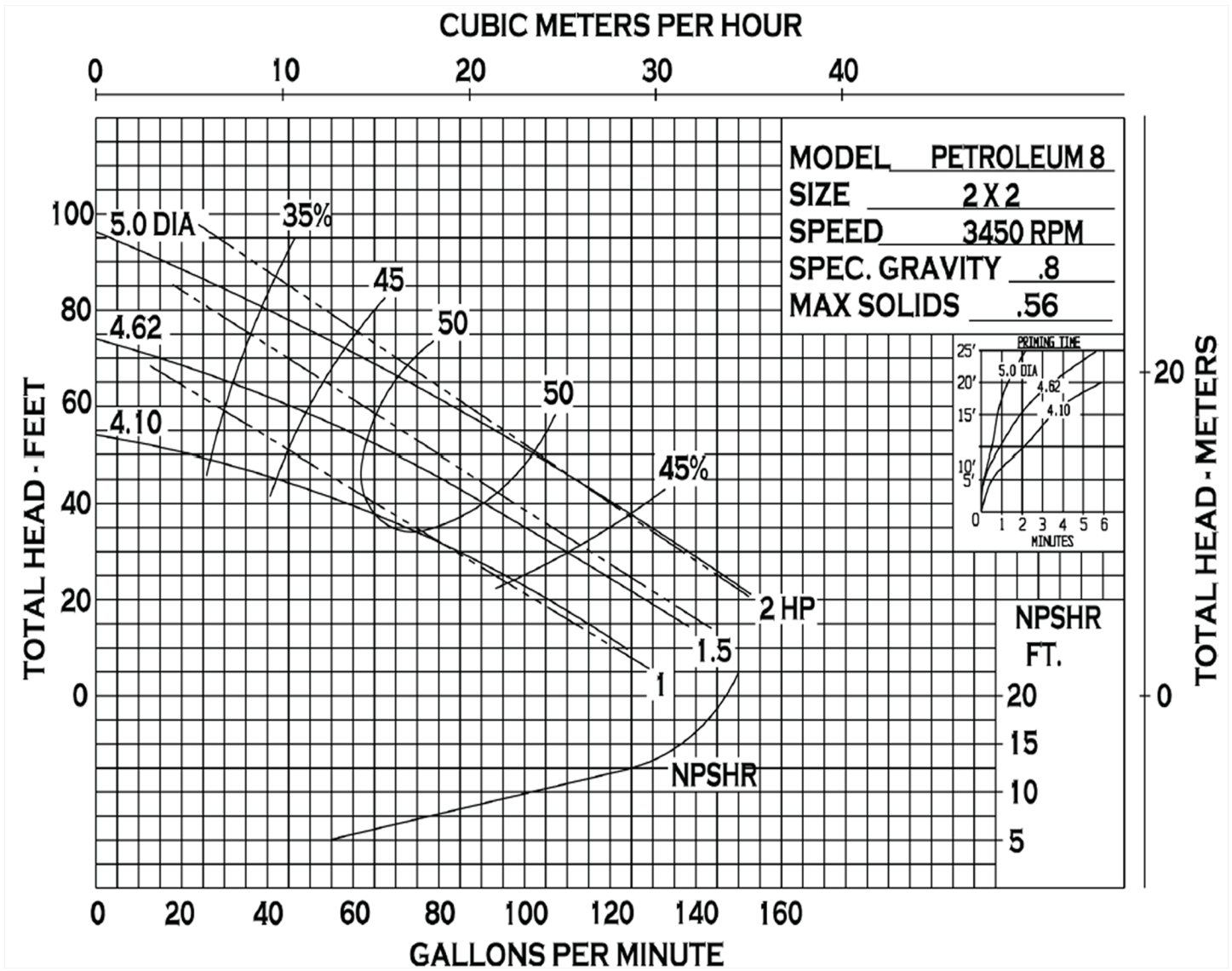

CLOSE COUPLED - ELECTRIC MOTOR

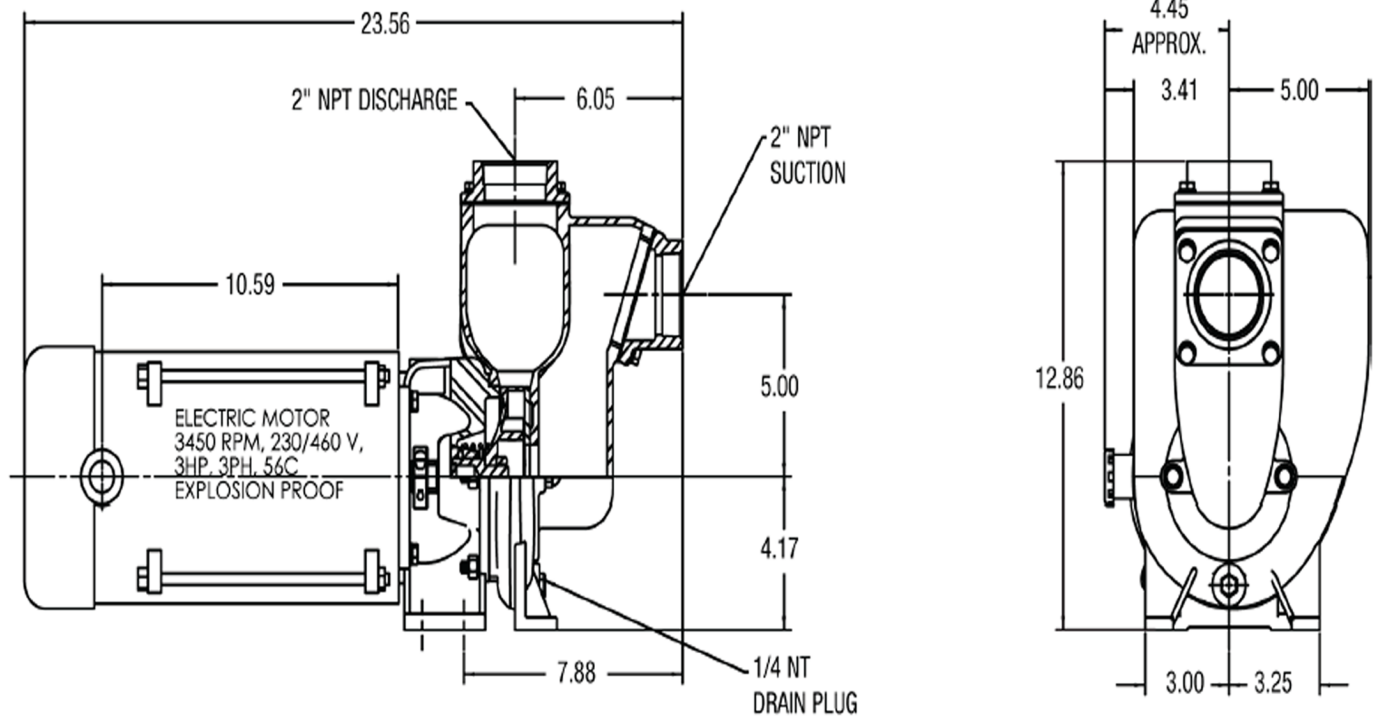

PEDESTAL-MOUNT

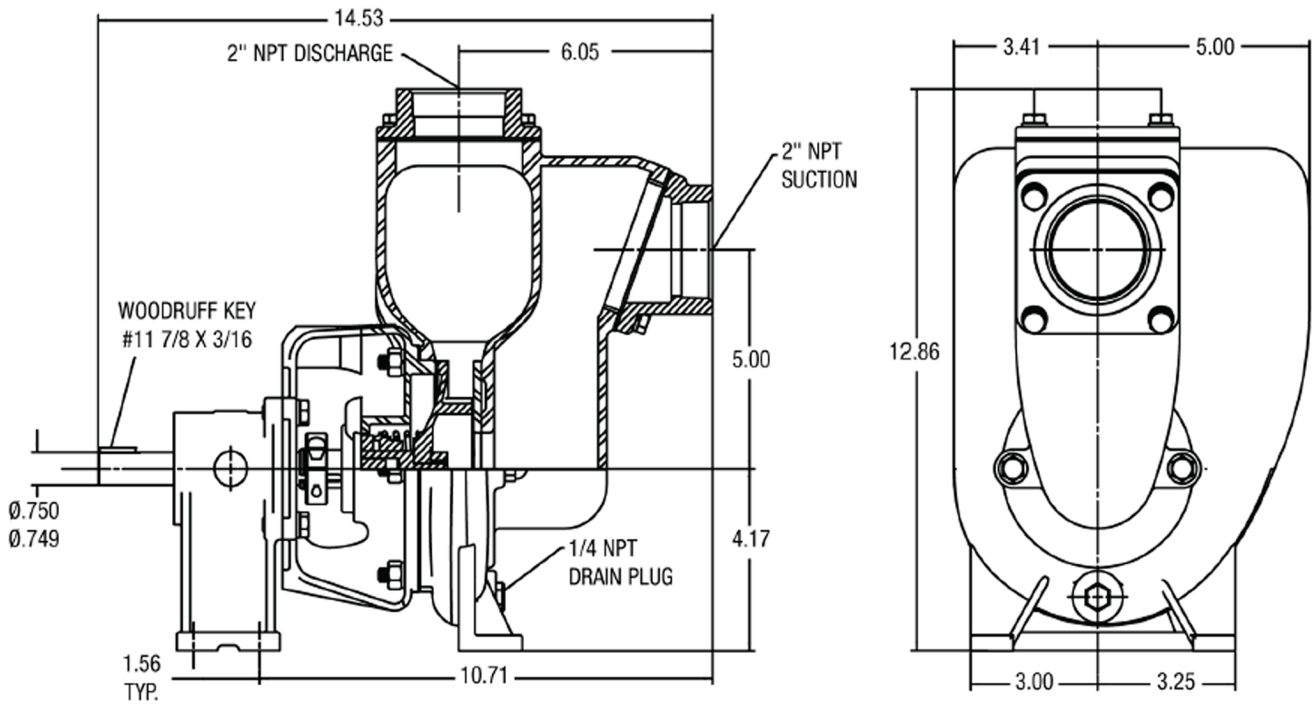

35639

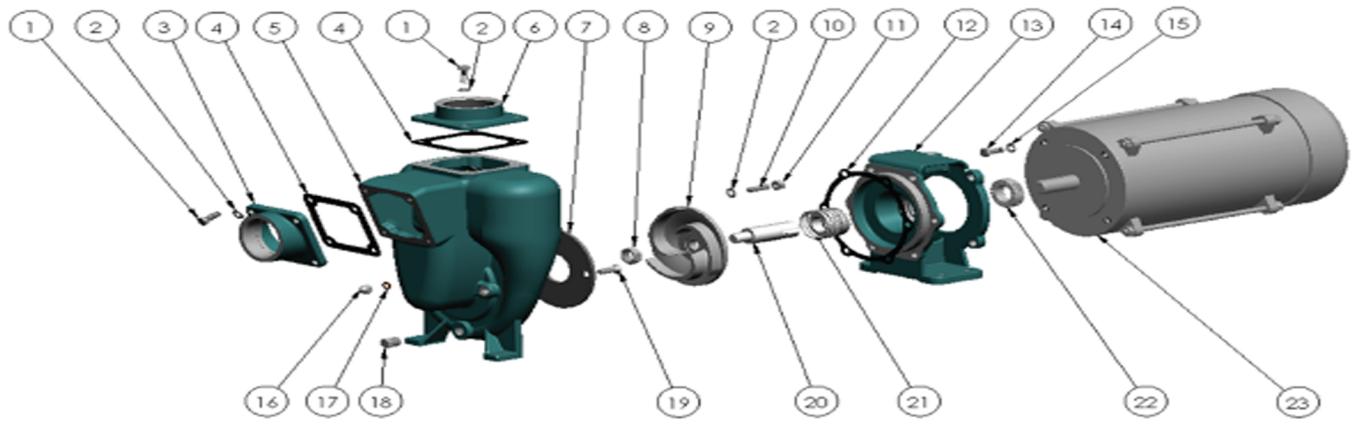

PART NO.	ITEM NO.	DESCRIPTION	QTY.		PART NO.	ITEM NO.	DESCRIPTION	QTY.
21242	1	CAPSCREW - 5/16"-18 X 7/8"	8		21266	15	LOCKWASHER SS: 3/8	4
21238	2	LOCKWASHER 5/16	14		21237	16	ACORN NUT - 5/16"-18	2
35614	3	SUCTION FLANGE D - 2" NPT	1	*	21248	17	GASKET - 1/2 X 5/16 X 1/16	2
* 35609	4	GASKET CORK/BUNA	2		21267	18	PIPE PLUG SS 1/4 NPT	1
35604	5	HOUSING DUCTILE	1		21249	19	SCREW SS 5/16-18X1	2
35615	6	DISCHARGE FLANGE D - 2" NPT	1		25664	20	DRIVE SLEEVE SS: 7/8 SL	1
* 22258	7	WEAR PLATE ALUMINUM	1	*	35610	21	SEAL 1" T-2 CAR/SIC/VIT	1
22655	8	JAM NUT - 5/8"-18	1		35613	22	CLAMP B: 7/8 SL	1
22293	9	IMPELLER C 5" DIA.	1		26027	23	EL MTR: 3-3 145TC 3450 230/460 EXPLOSION PROOF	1
30321	10	STUD - 5/16"-18 X 1.13"	6					
21284	11	HEXNUT - 5/16"-18	6					
* 35722	12	GASKET C-4433	1					
35608	13	ADAPTOR DUCTILE	1					
21251	14	CAPSCREW 3/8-16 X 7/8	4					

* SUGGESTED REPLACEMENT PARTS

** COMPATIBLE FOR KEROSENE, JET A/B & GASOLINE

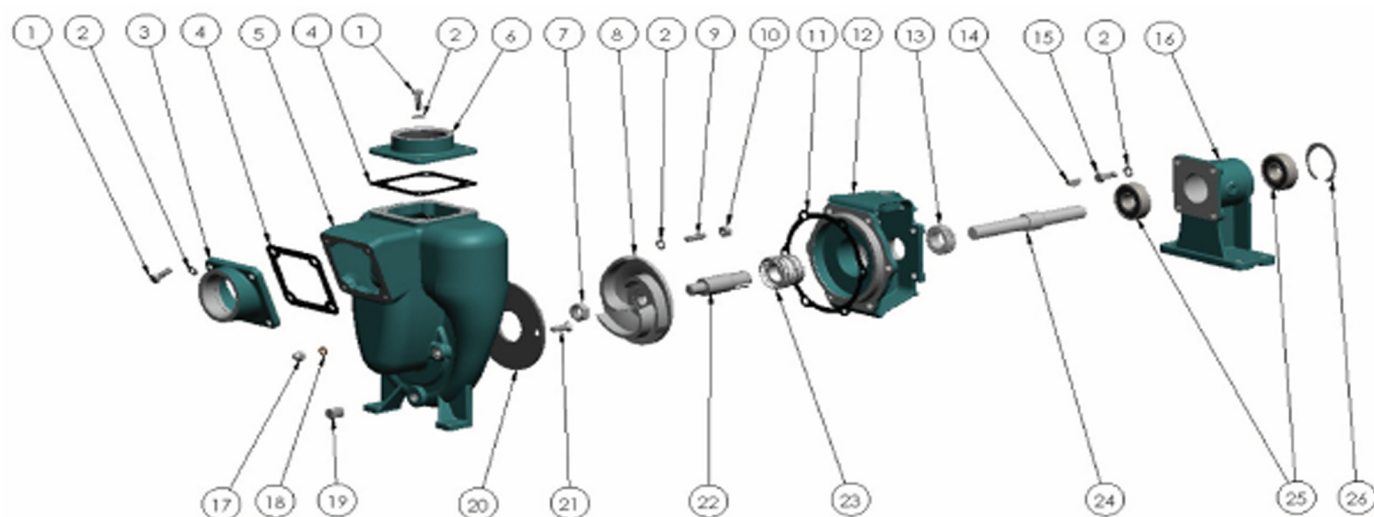

PART NO.	ITEM NO.	DESCRIPTION	QTY.		PART NO.	ITEM NO.	DESCRIPTION	QTY.
21242	1	CAPSCREW - 5/16"-18 X 7/8"	8		21278	15	CAPSCREW - 5/16"-24 X .88	4
21238	2	LOCKWASHER 5/16	18		26140	16	PEDESTAL C	1
35614	3	SUCTION FLANGE D - 2" NPT	1		21237	17	ACORN NUT - 5/16"-18	2
* 35609	4	GASKET CORK/BUNA	2	*	21248	18	GASKET - 1/2 X 5/16 X 1/16	2
35604	5	HOUSING DUCTILE	1		21267	19	PIPE PLUG SS 1/4 NPT	1
35615	6	DISCHARGE FLANGE D - 2" NPT	1	*	22258	20	WEAR PLATE ALUMINUM	1
22655	7	JAM NUT - 5/8"-18	1		21249	21	SCREW SS 5/16-18X1	2
22293	8	IMPELLER C 5" DIA.	1		22286	22	DRIVE SLEEVE SS - 3/4	1
30321	9	STUD - 5/16"-18 X 1.13"	6	*	35610	23	SEAL 1" T-2 CAR/SIC/VIT	1
21284	10	HEXNUT - 5/16"-18	6		26085	24	SHAFT STL	1
* 35722	11	GASKET C-4433	1		22300	25	BALL BEARING	2
35606	12	ADAPTOR DUCTILE	1		21695	26	SNAP RING	1
35612	13	CLAMP B: 3/4 SL.	1					
22321	14	WOODRUFF KEY STL	1					

* SUGGESTED REPLACEMENT PARTS

** COMPATIBLE FOR KEROSENE, JET A/8 & GASOLINE

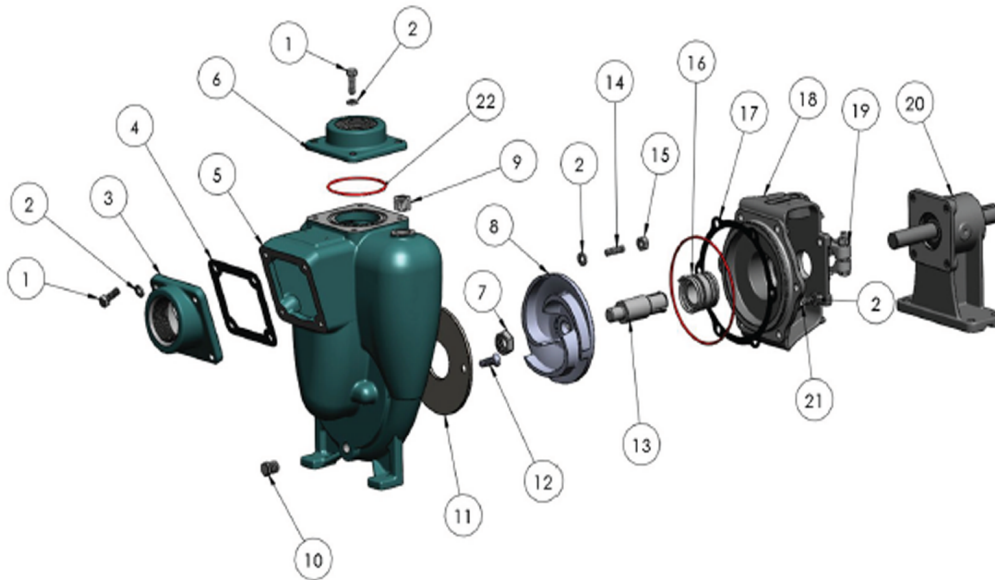

PART NO.	ITEM NO.	DESCRIPTION	QTY.		PART NO.	ITEM NO.	DESCRIPTION	QTY.
21242	1	CAPSCREW - 5/16"-18 X 7/8"	8		22286	13	DRIVE SLEEVE SS - 3/4	1
21238	2	LOCKWASHER 5/16	20		30321	14	STUD S.S. - 5/16"-18 X 1.13"	6
22387	3	SUCTION FLANGE C - 2" NPT	1		21284	15	HEXNUT S.S. - 5/16"-18	8
* 35609	4	GASKET CORK/BUNA	2	*	25460	16	SEAL 1" T-21 NRS	1
22251	5	HOUSING CAST	1	*	35722	17	GASKET C-4433	1
22311	6	DISCHARGE FLANGE C - 2" NPT	1		22247	18	ADAPTOR CAST	1
22655	7	JAM NUT - 5/8"-18	1		23002	19	CLAMP ASSY. S.S.: 3/4 SL.	2
22293	8	IMPELLER C 5" DIA.	1		26141	20	PEDESTAL ASSY. C	1
37140	9	1/2" NPT PIPE PLUG ZPS	1		21278	21	CAPSCREW - 5/16"-24 X .88	4
21267	10	PIPE PLUG SS 1/4 NPT	1	*	37141	22	O RING VITON - AS-568-149	1
* 22260	11	WEAR PLATE STEEL	1					
37137	12	FHS SCREW S.S. - 5/16-18 X .62	2					

* SUGGESTED REPLACEMENT PARTS

** COMPATIBLE FOR DIESEL, BIO-DIESEL & FUEL OIL