



# PETROLEUM 15

## 3" x 3" Self Priming Centrifugal Pump

Petroleum 15 self-priming centrifugal pumps are capable of creating vacuum sufficient to lift liquids from heights up to 25 feet above the source. To handle many different fuels, the Petroleum 15 is available in three distinct models: PO, PG and PE 15.

A Petroleum 15 PumPAK® is a fully assembled and run tested pump end that can be easily coupled to a number of drivers such as hydraulic motors, 184TC and 215C frame motors and gas engines. A bearing pedestal is also available for T-frame motor or belt drive.

Standard features include SS drive sleeve, SS fasteners, renewable wear plate, and a semi-open dynamically balanced impeller.

The Petroleum 15 Pump is available in three distinct models: PG, PO and PE  
 Model PG Pumps - Compatible For Gasoline, Kerosene, Avgas & Jet Fuel  
 Model PO Pumps - Compatible For BioDiesel, Fuel Oil & Diesel  
 Model PE Pumps - Compatible For Ethanol & E 85

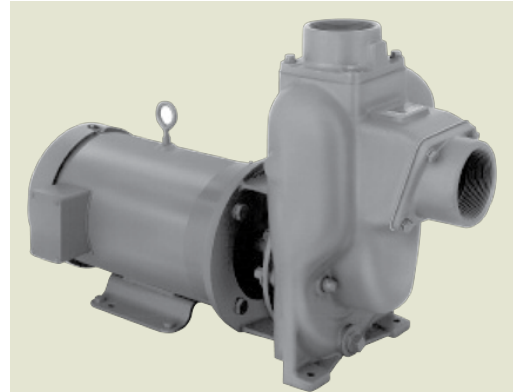

### Application

- Agricultural
- Industrial
- Marine
- OEM

### Features

- Gas engine for diesel fuel transfer
- Non-spark clamp (on some models)
- Renewable wear plate
- Stainless steel drive sleeve
- Stainless steel fasteners
- Up to a 25' suction lift

## SPECIFICATIONS:

Suction And Discharge	3" x 3" NPT
Materials Of Construction	Cast iron, Ductile iron
Flow	Up to 320 GPM
Head Feet	Up to 145'
Impeller	PE 15 - semi-open cast iron, 316 SS (optional), PG 15 - semi-open cast iron, aluminum (optional), PO 15 - semi-open cast iron
Motor	Up to 7.5 HP
Drive Options	Close coupled 184TC, Engine mount 11 HP, Engine mount 13 HP, Engine mount 5.5 HP, Engine mount 6.5 HP, Hydraulic motor .73 cu. in., Pedestal, PumPAK® (without motor)
Seal	PE 15 - carbon / silicon carbide / Viton, PG 15 - carbon / silicon carbide / Viton, PO 15 - carbon / Ni-Resist / Viton
Compatible For	PE 15 - ethanol, E 85, PG 15 - gasoline, avgas, kerosene, jet A/8, PO 15 - biodiesel, fuel oil, diesel

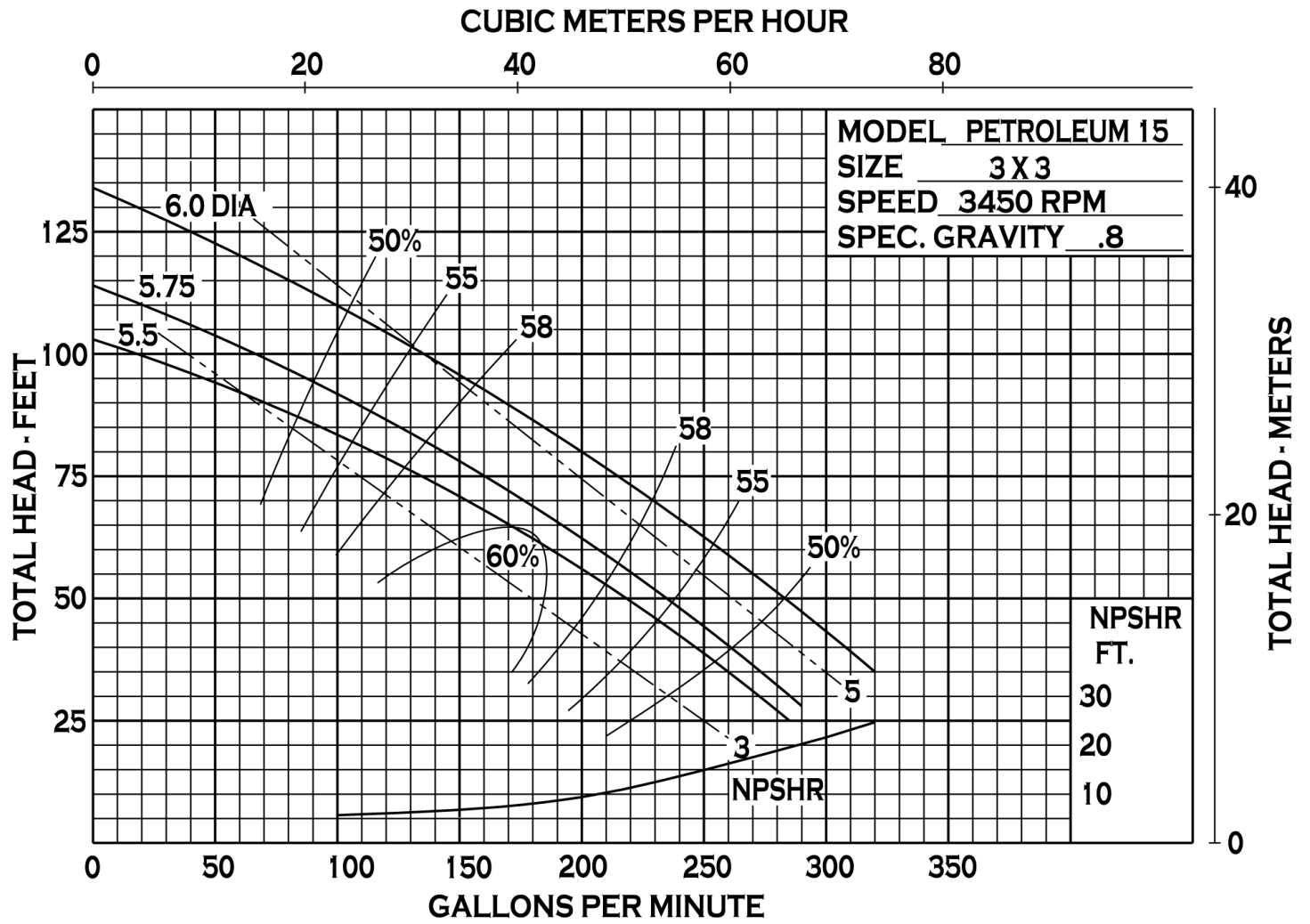

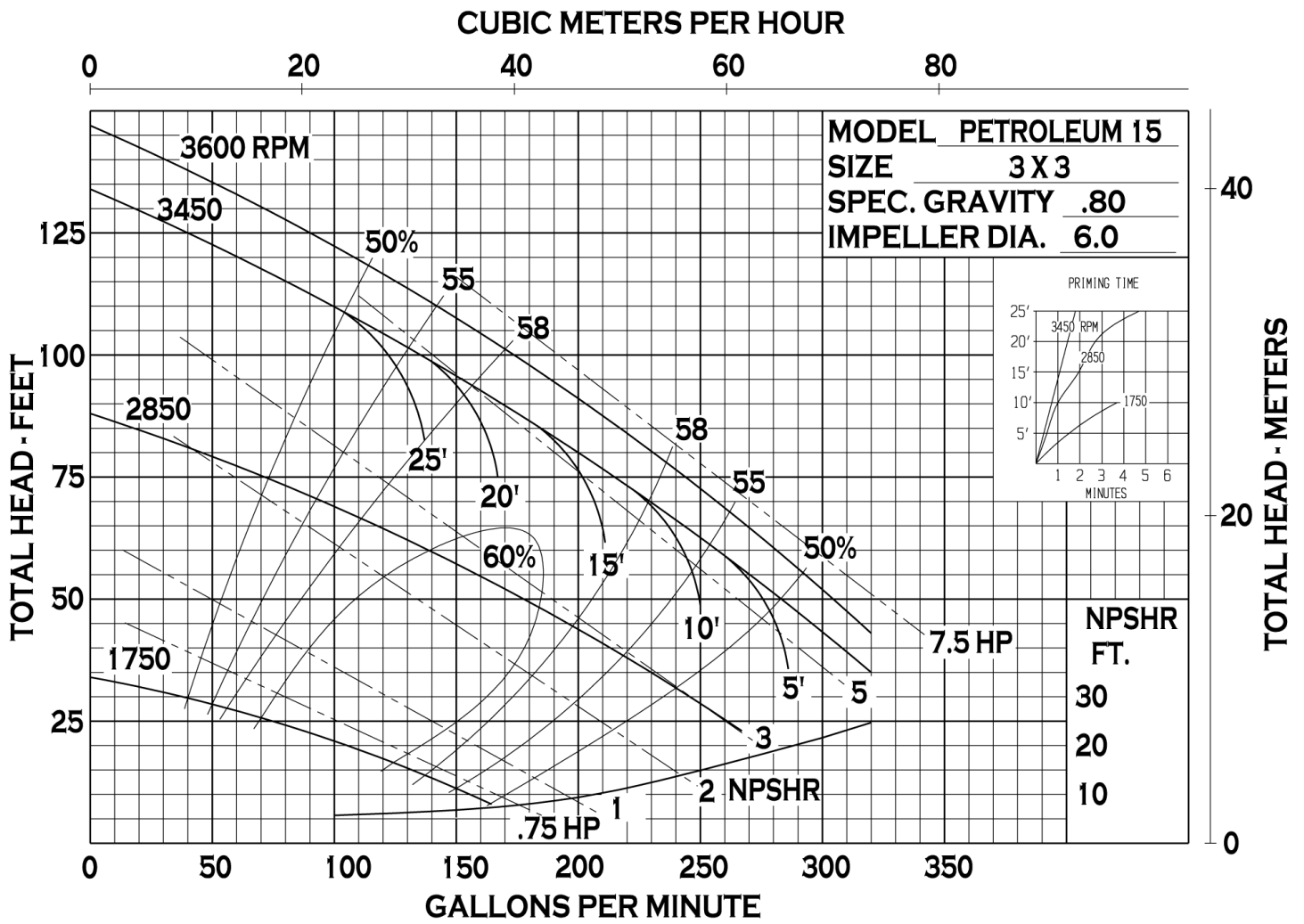

34800 BENNETT - FRASER, MI 48026-1686  
 (586) 293-8240 - FAX (586) 293-8469  
 (800) 563-8006 - www.mppumps.com

## CLOSE COUPLED - ELECTRIC MOTOR

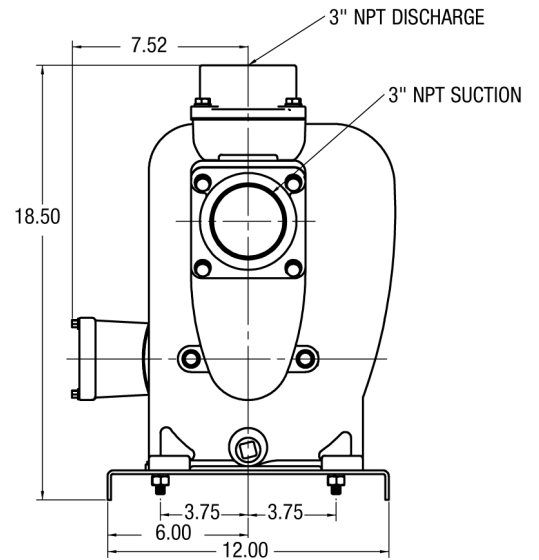
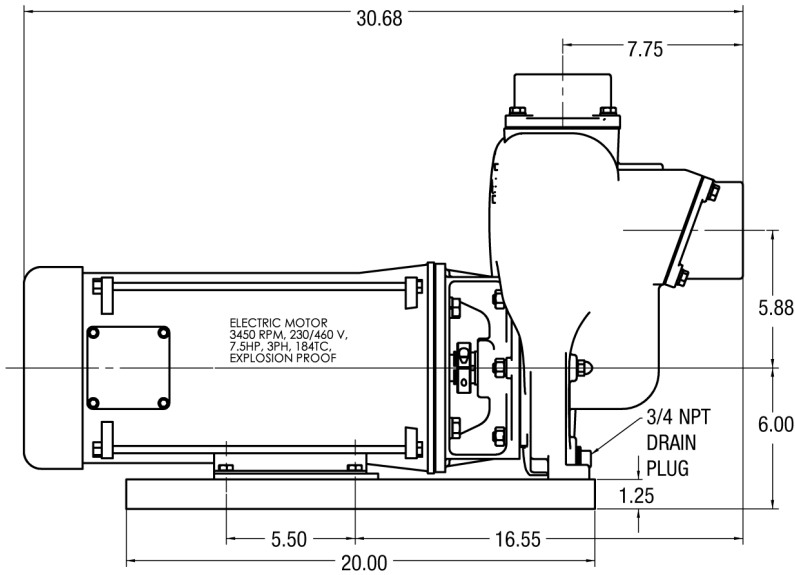

## PEDESTAL-MOUNT

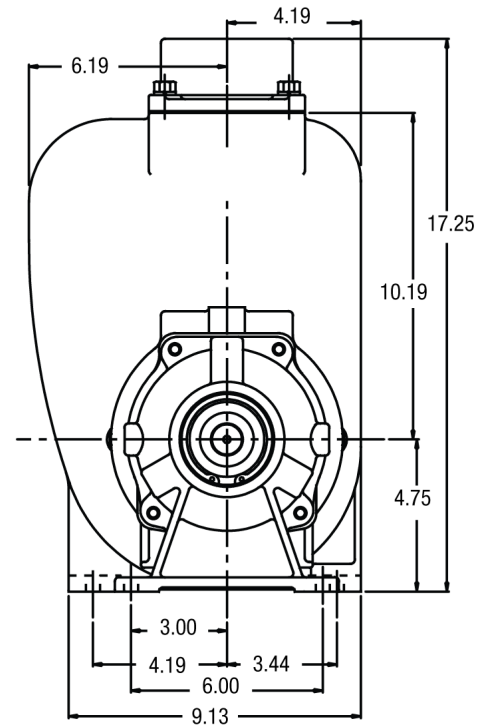
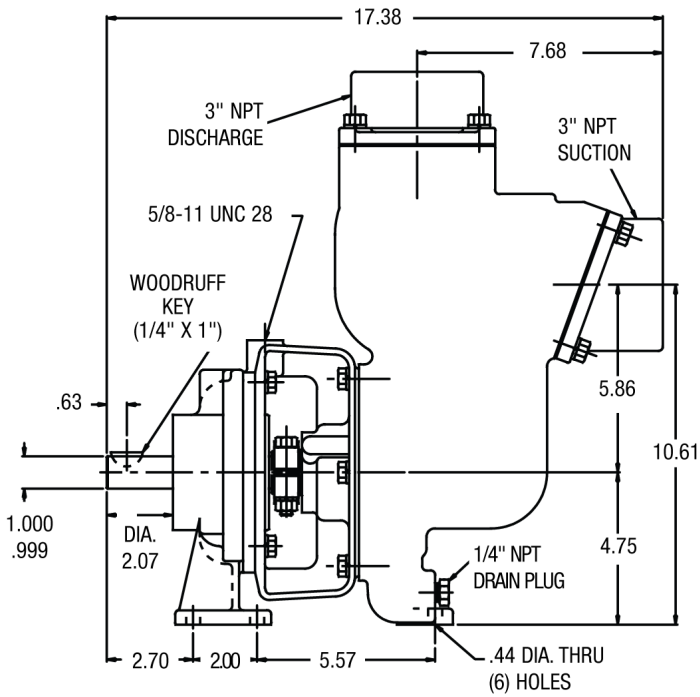

36048

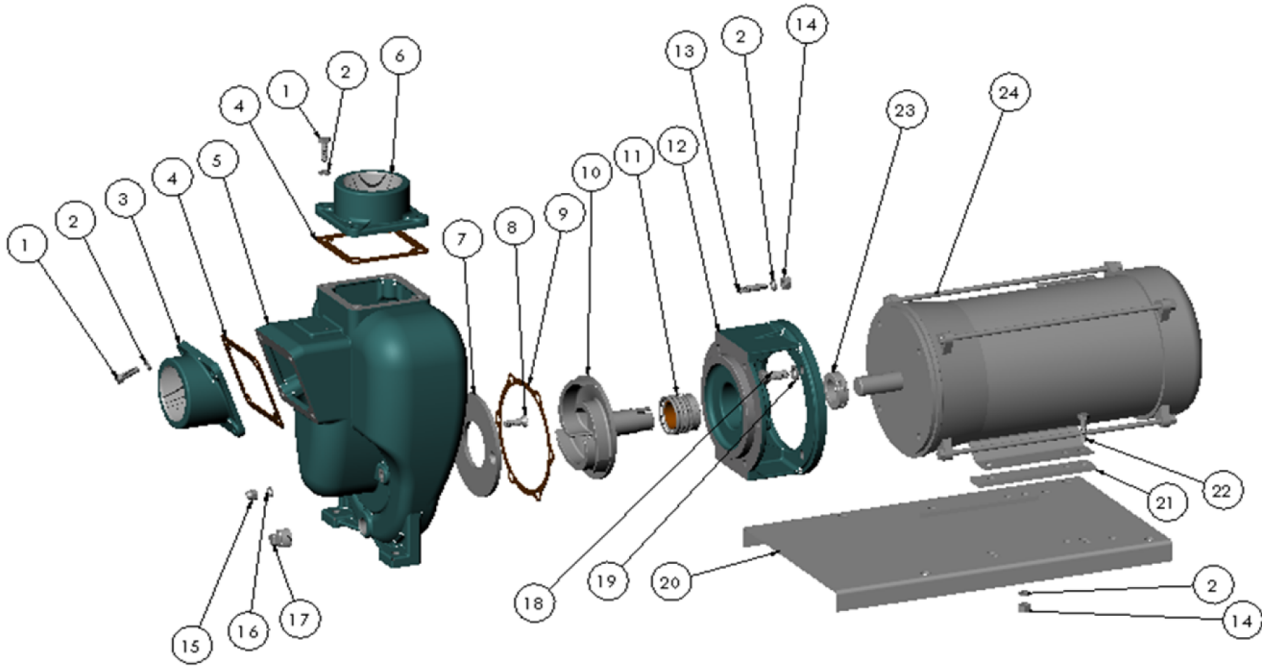

PART NO.	ITEM NO.	DESCRIPTION	QTY.	PART NO.	ITEM NO.	DESCRIPTION	QTY.
21291	1	CAPSCREW SS - 3/8-16 X 1.13"	8	21268	14	HEX NUT SS - 3/8-16	10
21266	2	LOCKWASHER SS 3/8"	18	21263	15	ACORN NUT - 3/6-16	2
35628	3	SUCTION FLANGE D - 3" NPT	1	* 21271	16	GASKET - 5/8 X 3/8 X 1/16	2
* 35630	4	GASKET CORK/BUNA	2	35650	17	PIPE PLUG SS 3/4 NPT	1
35625	5	HOUSING DUCTILE	1	21246	18	HEX HD SCREW SS 1/2-13 X 1.25	4
35629	6	DISCHARGE FLANGE D - 3" NPT	1	21254	19	LOCKWASHER SS - 1/2	4
* 22242	7	WEAR PLATE ALUMINUM	1	22423	20	BASE - ZPS	1
21262	8	FLAT HD SCR. SS - 3/8-16 X 1.25	2	24710	21	SPACER STL.	2
* 35721	9	GASKET - C-4433	1	21259	22	HEX HD SCREW SS 3/8-16 X 1.38	4
22499	10	IMPELLER D 5.75" DIA 1.13 I.D.	1	35649	23	CLAMP B	1
* 35651	11	SEAL 1.5" T-2 CAR/SIC/VIT	1	27585	24	EL MTR: 5-3 184TC 3450/2850	1
35627	12	ADAPTOR DUCTILE	1			EXPLOSION PROOF	
21261	13	STUD SS - 3/8-16 X 1.63	6				

\* SUGGESTED REPLACEMENT PARTS

\*\* COMPATIBLE FOR KEROSENE, JET A/8 & GASOLINE

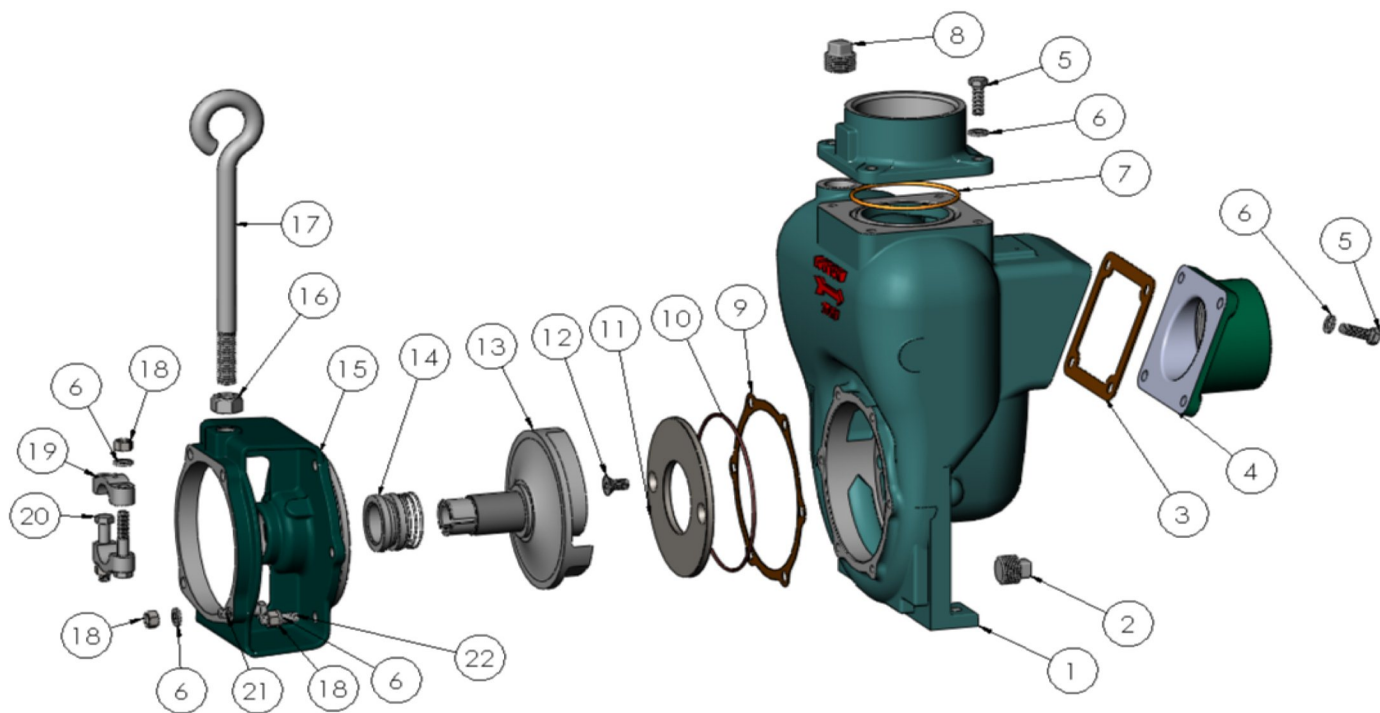

PART NO.	ITEM NO.	DESCRIPTION	QTY.		PART NO.	ITEM NO.	DESCRIPTION	QTY.
22351	1	HOUSING C	1		23038	13	IMPELLER S/A - D 6.0 DIA.	1
35650	2	PIPE PLUG S.S. - 3/4" NPT	1	*	22363	14	SEAL- 1.5" - TYPE 21 CAR/NRS VITON	1
* 35630	3	GASKET SUCTION - BUNA	1		22345	15	ADAPTER C	1
22468	4	FLANGE - SUCTION C	1		22461	16	HEX NUT STL - 5/8-11	1
21291	5	CAP SCREW S.S.- 3/8-16 X 1.13"	8		22460	17	LIFT EYE ZPS 5/8-11 X 10"	1
21266	6	LOCK WASHER- 3/8	20		21268	18	HEX NUT - S.S. 3/8-16	12
* 37138	7	O RING DISCHARGE - VITON	1		22356	19	CLAMP S.S.- 1"	2
41481	8	PIPE PLUG C - 3/4" NPT	1		21269	20	CAP SCREW- S.S. 3/8-16 X 2.25"	2
* 35721	9	GASKET - KINGERSIL C-4433	1		21256	21	CAP SCREW- S.S. 3/8-16 X 1.38"	4
* 29715	10	O RING - VITON	1		21260	22	STUD S.S. - 3/8-16 X 1.32"	6
* 22244	11	WEAR PLATE STL.	1					
37115	12	FLAT HD. SCR. S.S. - 3/8-16 X .75"	2					

\*- RECOMMENDED REPLACEMENT PARTS