

Product Information

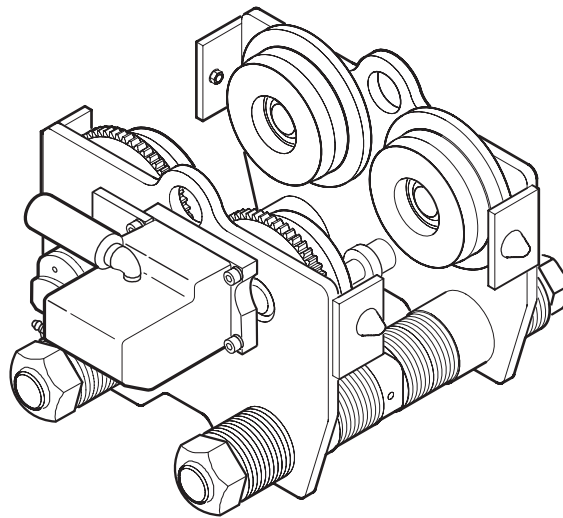

Plain, Hand Chain (Geared) and Air Powered Trolleys Models

TR2U015, TR2U040, TR2U080, TR2U120 and TR2U250



(Dwg. MHP2671)



Save These Instructions

Only allow **Ingersoll Rand** trained technicians to perform maintenance on this product. For additional information contact **Ingersoll Rand** factory or nearest Distributor.

For additional supporting documentation refer to Table 1, 'Product Information Manuals' on page 2. Manuals can be downloaded from www.irtools.com

The use of other than genuine **Ingersoll Rand** replacement parts may result in safety hazards, decreased performance and increased maintenance and will invalidate all warranties.

The original language of this manual is English.

Refer all communications to the nearest **Ingersoll Rand** Office or Distributor.

Table 1: Product Information Manuals

Publication	Document/Part Number	Publication	Document/Part Number
Product Safety Information Manual (Non-Man Rider Trolley)	MHD56291	Product Maintenance Information Manual	MHD56446
Product Parts Information Manual	MHD56425		

SPECIFICATIONS

Model Code Explanation

Example: TR2U040-3U2MUL-E

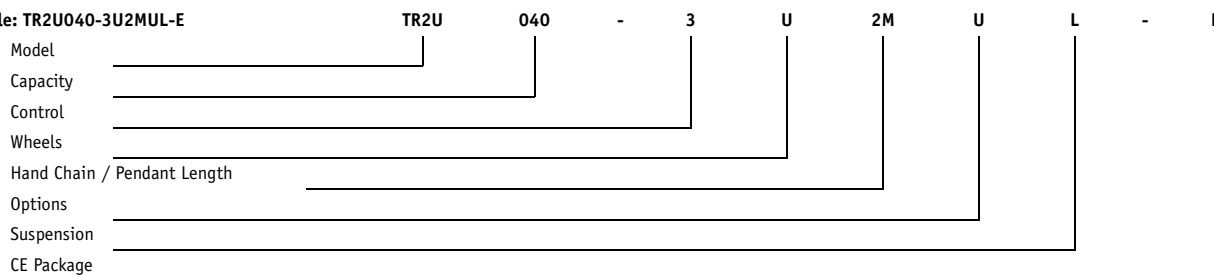

Model	Capacity (t = metric ton)
TR2U = Trolley series	015 = 1.5t 040 = 4t 030M= 3t - Special mining model for INP140 beam (Form MHD56289) 080 = 8t 120 = 12.5t 250 = 25t
Control	Wheels
P = Plain G = Geared (not available on 25t trolley) 0(*) = Gear motor, no pendant 2(*) = Gear motor with one motor pendant 3(*) = Gear motor with two motor pendant H = Hydraulic no Control (on request) (*) Add the letter "R" for rack and pinion configuration (only possible on flat beam)	U = Universal (1.5t, 4t and 8t models) E = Flat beam (12.5t and 25t models) N = Tapered beam (12.5t and 25t models)
Hand Chain / Pendant Length	Options
2M = 2 metres (standard) XM = Specify length (in metre) OM = No hand chain or remote hoses	T ₁ = Spark resistance package (*) P = Marine paint (150 μ) Q = Offshore paint (290 μ) Z = Sandblast and primer U = Emergency stop device (for pendant models only) A = Articulated Trolley (on request) K = Cast iron pendant L = Low Temperature (TD-20) * Option T ₁ includes the following: - Stainless steel pins and fasteners 10 mm and smaller - 20 microns zinc plated fasteners larger than 10 mm - Solid bronze wheels - Rubber bumpers - Zinc plated hand chain (if any) - Zinc plated hand wheel (if any) - Cast iron pendant (if any)
Suspension	CE Package
L = Lug adaptor for LC2A015 and O30D only MHD56289 LS = Lug adaptor for Liftchain LCA on single fall LD = Lug adaptor for Liftchain LCA on double falls LT = Lug adaptor for Liftchain LCA on triple falls LQ = Lug adaptor for Liftchain LCA on quadruple falls HA = Hook-on adaptor PN = Plain, no lug	-E = Compliance with the European Machinery Directives (**): - Includes a main air shut off valve on air inlet - Implies the need to also select the option U (emergency stop) (**) The "-E" option is not necessary if trolley is to equip an Ingersoll Rand "CE" hoist (as the hoist shut-off valve will stop the main air for both the hoist and the trolley).

Table 2: Performance Specifications

		Model									
		TR2U015		TR2U040		TR2U080		TR2U120		TR2U250	
Maximum Load Capacity		3,300 lbs	1,500 kg	8,800 lbs	4,000 kg	13,200 lbs	6,000 kg	27,500 lbs	12,500 kg	55,000 lbs	25,000 kg
Beam Size	Minimum Width	3.2 in	80 mm	3.2 in	80 mm	3.7 in	98 mm	5.1 in	131 mm	5.6 in	143 mm
	Maximum Width	8.1 in	200 mm	12.2 in	310 mm	12.2 in	310 mm	12.2 in	310 mm	12.2 in	310 mm
	Minimum Height w/Hoist	17.6 in	448 mm	24.1 in	604 mm	30.7 in	781 mm	39.4 in	1,001 mm	49.3 in	1,253 mm
Minimum Turning Radius		3.3 ft	1 m	6.56 ft	2 m	9.84 ft	3 m	9.84 ft	3 m	16.4 ft	5 m
Working Pressure*		90 psig	6.3 bar	90 psig	6.3 bar	90 psig	6.3 bar	90 psig	6.3 bar	90 psig	6.3 bar
Trolley Travel Speed*	Rated Load	59.1 ft/min	18 m/min	49 ft/min	15 m/min	39.4 ft/min	12 m/min	39.4 ft/min	12 m/min	39.4 ft/min	12 m/min
	No Load	75.5 ft/min	23 m/min	69 ft/min	21 m/min	49.2 ft/min	15 m/min	49.2 ft/min	15 m/min	49.2 ft/min	15 m/min
Maximum Air Consumption at 90 psi (6.3 bar)		46 scfm	1.3 m ³ /min	46 scfm	1.3 m ³ /min	67 scfm	1.9 m ³ /min	67 scfm	1.9 m ³ /min	67 scfm	1.9 m ³ /min
Sound Level		Lpc (Peak Sound Pressure) does not exceed 130 dB.									
Trolley Weight (Plain)**		49 lbs	22,5 kg	114 lbs	52 kg	317 lbs	116 kg	361 lbs	164 kg	789 lbs	358 kg
Trolley Weight (Motorized)**		57 lbs	26 kg	123 lbs	56 kg	289 lbs	131 kg	399 lbs	181 kg	827 lbs	375 kg
Trolley Weight (Geared)**		55 lbs	25 kg	128 lbs	58 kg	267 lbs	121 kg	377 lbs	171 kg	816 lbs	370 kg

The following air supply specifications should be maintained at the trolley air motor:

Air Pressure	90 psig (6.3 bar/630 kPa)
Air Filtration	20 micron
Inlet Hose Size	1/2 in inside dia. (13 mm inside dia.)

* Speed variable depending on amount of pendant lever movement.

** Trolley weights are for a standard non -E model.

INSTALLATION

Prior to installing the product, carefully inspect it for possible shipping damage. Products are supplied fully lubricated from the factory. Check oil levels and adjust as necessary before operating product. Refer to "LUBRICATION" section on page 6 for recommended oils and lubrication levels.



WARNING

- Prior to installation refer to Product Safety Information Manual for all sections of installation.
- To avoid an unbalanced load which may damage the trolley, the spacers (31-39 and 86-88) must be installed equally between side plates (6 and 7) and support lug (27) to ensure hoist is centered on trolley.

NOTICE

- Trolley wheels ride on the top of the lower flange of the beam.
- During assembly lubricate gears, shafts, and bearings with applicable lubricants. Use of Loctite® on capscrew and nut threaded areas will help prevent corrosion.

■ Mounting

Make certain your trolley is properly installed. A little extra time and effort in doing so can contribute a lot toward preventing accidents and helping you get the best service possible.

Always make certain the supporting member from which the trolley is suspended is strong enough to support the weight of the trolley plus the weight of the maximum rated load plus a generous factor of at least 500% of the combined weights.

Refer to Dwg. MHP1537 on page 8, **A.** Spacers equal on both sides of hoist adapter and side plates; **B.** Hoist adapter centered under I-Beam; **C.** Wheel; **D.** Beam; **E.** Clearance 0.09 - 0.15 in (2-4 mm).

■ Adjustment

When installing a trolley on a beam, measure beam flange, temporarily install hoist on trolley to determine the exact distribution and arrangement of the spacers.

Distance between each wheel flange and beam flange should be 3/32 to 5/32 in (2 to 4 mm).

NOTICE

- The total clearance between the beam and the trolley wheel flanges is 3/16 to 5/16 inches (4 to 8 mm) when trolley is installed correctly as shown in Dwg. MHP1537 on page 7. The difference between dimensions "X" and "Y" equals the total clearance.

1.5 ton

1. Measure beam flange width and estimate required position for washers (31). Position of washers must be the same on both suspension shafts.
2. Install estimated number of washers (31) on one end of both suspension shafts (8) before installing assembled side plate (6).
3. Install assembled side plate (6) on suspension shafts (8).
4. Install required outside washers (31) on suspension shafts (8).
5. Apply Loctite® 243 to suspension shaft threads and fasten nuts (42) on suspension shafts to lightly clamp spacers.
6. Install hoist support lug (27) on suspension shafts.
7. Install equal number of spacers on opposite end of suspension shafts followed by second assembled side plate (7).
8. Install remaining washers (31) equally to the outside of side plate (7) on suspension shafts (8). Loosely install nuts (42) on other side of suspension shafts.
9. Apply a small amount of Loctite® 243 to threads on setscrews (18) and install in hoist support lug (27).

4 and 8 ton

The number of washers (31) and spacers (39) between the trolley side plate (6) and the hoist support lug (9) or hoist adapter (29) must be the same on both sides in order to keep the trolley and hoist centered under the beam. The remaining spacers must be equally distributed on the outside of the side plates.

1. Fasten nut (42) and locknut (32) to one end of each suspension shaft (8), apply Loctite® 243 to suspension shaft threads. Locknut (32) not required on 8 ton models.
2. Measure beam flange width and establish required position for spacers. Install required outside washers (31) and spacers (39) on suspension shaft (8).

3. Insert suspension shafts (8) through side plate (6).
4. Install an equal number of washers (31) and spacers (39) to each side of hoist adapters (29) and spacers (38), on suspension shaft.
5. Install second side plate (6) or (7) on suspension shaft.
6. Install remaining washers (31) and spacers (39) equally to the outside of side plate (6) on suspension shafts (8). Loosely install nuts (42) and locknuts (32) on other side of suspension shafts.

12.5 and 25 ton

The number of washers (31) and spacers (39) between the trolley side plates (6) and (7) and the hoist support must be the same on both sides in order to keep the trolley and hoist centered under the beam. The remaining spacers must be equally distributed on the outside of the side plates.

1. Fasten end cap (89) to one end of suspension shaft (8), using lockwashers (87) and capscrews (88), apply Loctite® 243 to capscrew threads.
2. Measure beam flange width and establish required position for spacers. Install required outside spacers on suspension shaft (8).
3. Thread a nut (26) onto each end of the screw rod (91), as far to the center as possible.
4. Insert one end of the screw rod into the side plate and fasten loosely with another nut (26).
5. Insert suspension shaft (8) through side plate (6).
6. Install an equal number of spacers to each side of hoist adapter (9), on suspension shaft.
7. Install second side plate (7) on suspension shaft (ensure screw rod (91) goes through hoist adapters (29) and this side plate). Place the rest of spacers (31) and (39) on the suspension shaft (8) and loosely secure with end cap (89), lockwashers (87) and capscrews (88).

■ Trolley Installation over the Open End of the Beam

Pre-adjust trolley for installation using Dwg. MHP1537 on page 8 and the instructions in the 'Adjustment' section on page 3.

1.5 to 8 ton

1. Verify trolley wheel to beam total clearance. Adjust spacer locations until clearance specification is attained. Apply Loctite® 243 to suspension shaft threads and secure in place with nuts (42) and (32).

12.5 and 25 ton

1. Verify trolley wheel to beam total clearance. Adjust spacer locations until clearance specification is attained. Ensure end caps (89) are secured on suspension shaft (8) with lockwashers (87) and capscrews (88). Check nuts (26) are secure on screw rod (91).

All capacities

1. Remove beam stops and slide trolley assembly onto the beam.
2. Upon completion of installation, ensure trolley beam stops are installed and conduct initial operating checks as described in "OPERATION" section on page 5.

■ Trolley Installation from Underneath the Beam

1.5 ton

Pre-adjust trolley for installation using Dwg. MHP1537 on page 7 and steps 1 through 9 from the instructions in the 'Adjustment' section on page 3.

1. Support the assembled trolley under the beam.
2. Remove nuts (42) and spacers (31) from suspension shafts (8) on one side plate.
3. Carefully separate side plates until trolley wheels clear beam flange.
4. Lift trolley assembly into place on the beam and slide side plates back together.
5. Install removed spacers (31) and nuts (42) on suspension shafts (8). Apply a small amount Loctite 243 to suspension shaft (8) threads. Refer to "TORQUE CHART" in Product Maintenance Information manual for torque requirements.
6. Verify trolley wheel to beam total clearance.
7. Install trolley motor on motorized trolleys.

4 and 8 ton

Pre-adjust trolley for installation using Dwg. MHP1537 on page 7 and steps 1 through 6 from the instructions in the 'Adjustment' section on page 3.

1. Support the assembled trolley under the beam.
2. Remove locknuts (32), nuts (42) and spacers (31) from suspension shafts (8) on one side plate. Locknuts (32) are not required on 8 ton models.
3. Carefully separate side plates until trolley wheels clear beam flange.
4. Lift trolley assembly into place on the beam and slide side plates back together. Ensure bearing (14) is located against the underside of the beam flange.
5. Install removed spacers (31), nuts (42) and locknuts (32) on suspension shafts (8). Apply a small amount Loctite 243 to suspension shaft (8) threads. Refer to "TORQUE CHART" in Product Maintenance Information manual for torque requirements.
6. Verify trolley wheel to beam total clearance.
7. Install trolley motor on motorized trolleys.

12.5 and 25 ton

Pre-adjust trolley for installation using Dwg. MHP1537 on page 7 and steps 1 through 7 from the instructions in the 'Adjustment' section on page 3.

1. Support the assembled trolley under the beam.
2. Remove capscrews (88), lockwashers (87) and end cap (89) from suspension shaft (8) on one side plate.
3. Remove nut (26) from end of screw rod (91).
4. Carefully separate side plates until trolley wheels clear beam flange.
5. Lift trolley assembly into place on the beam and slide side plates back together.

6. Install removed end cap (89), lockwashers (87) and capscrews (88) on suspension shaft (8). Apply a small amount Loctite 243 to suspension shaft (8) threads. Refer to "TORQUE CHART" in Product Maintenance Information manual for torque requirements.
7. Install nut (26) on screw rod (91).
8. Verify trolley wheel to beam total clearance.
9. Install trolley motor on motorized trolleys.

All capacities

1. Upon completion of installation, ensure trolley beam stops are installed and conduct initial operating checks as described in "OPERATION" section on page 5. Check that side plates are vertical and parallel to each other and that side plates are perpendicular to beam.

■ Trolley Rack Drive (optional)

Install the trolley rack drive onto the support beam. Installation should only be done by authorized service personnel.

■ Pre-Installation Checks

Refer to Dwg. MHP2990 on page 9, **A.** Rack; **B.** Pinion; **C.** Maintain clearance between rack and pinion teeth of 0.16 inch (minimum) to 0.20 inch (maximum) [4 to 5 mm] to prevent pinion binding during operation. Measure gap between the outside diameter of drive pinion and root of rack segment.

Before welding the rack segments onto the trolley beam, install the rack segments on the bottom of the beam lower flange and clamp in place. Mount the trolley on the lower beam flange. Measure the gap between the outside diameter of the drive pinion and root of rack segment teeth. As shown in Dwg. MHP2990 on page 9, the trolley drive pinion and rack teeth must have a 0.16 to 0.20 inch (4 to 5 mm) clearance.

■ To Adjust Clearance

Refer to Dwg. MHP2991 on page 10, **A.** Mounting Capscrew; **B.** Jam Nut; **C.** Adjustment Screw.

There is an adjustment screw located below the reducer adapter.

1. Loosen capscrews attaching trolley drive to side plate.
2. Loosen jam nut and rotate adjustment screw to achieve clearance as shown in Dwg. MHP2990 on page 9.
3. Tighten jam nut and mounting screws.

If a larger adjustment is required:

1. Add shims between the rack segment and beam to decrease distance.
2. Remove material from rack segment to increase distance.

■ Installing Rack Segments Onto Beam

Refer to Dwg. MHP1178 on page 10, **A.** Hoist Trolley Drive Assembly mounted this side; **B.** Lower Beam Flange; **C.** Rack Segment; **D.** Fillet Weld: Allow 1/4 inch (6.5 mm) clearance between edge of lower flange and rack segment. Apply weld to both sides of rack segment. Refer to Dwg. MHP3016 on page 10, **A.** Stagger welds along rack; **B.** (Not to scale); **C.** Check clearance between racks; **D.** Use the rack guide for correct track positioning.

Rack segments should be installed on the outside edge of the lower flange of the trolley beam. Allow 1/4 inch (6.5 mm) clearance between the edge of the lower flange and rack segment for fillet weld. The rack segments should be clamped tight against the lower flange so that there is no sagging. Sagging of the rack could cause the drive pinion to bind as it traverses along the runway beam.

Racks are provided in segments. These segments should be tack welded (refer to Dwg. MHP3016 on page 10) in place and the trolley traversed the entire length. During this movement observe for any high or low spots and correct. Also check each segment connection for drive tooth contact and correct as necessary. When all clearances are achieved, weld both sides of the rack to the beam flange to prevent corrosion between the rack segment and beam.

■ Hoist Installation

■ Hook Mount

When the hoist is suspended by a top hook, the supporting member should rest completely within the saddle of the hook and be centered directly above the hook shank. Do not use a supporting member that tilts the hoist to one side or the other.

1. Place the hoist top hook in the hoist support plate. Ensure hook latch is engaged.

■ Fixed Mount

When a fixed mount suspends the hoist, ensure that the mounting capscrews and nuts are tight. The hoist should hang level, if the hoist tilts then rotate the adapter 180°.

■ Motor Installation

NOTICE

- To prevent damage to the motor, install trolley to beam and hoist to trolley before installing motor to trolley.

1. Align trolley assembly geared wheels (3) and drive pinion gear on air motor. Liberally coat drive pinion gear and geared wheel (3) teeth with grease. Refer to "LUBRICATION" section on page 6.
2. Secure motor to trolley by installing lockwashers (63) and capscrews (62).
3. Connect pendant air hoses to air motor or shut off valve if equipped. Refer to Dwg. MHP1598 in Product Parts Information Manual.

⚠ CAUTION

- To avoid damaging the pendant hose, make sure the strain relief cable, not the pendant hose, is supporting the weight of the pendant.
- Check all hose connections are tight and that hoses are not twisted or crimped.

■ Air System Requirements

■ Air Supply

The air supply must be clean and free from moisture. Refer to Table 2 in the "SPECIFICATIONS" section on page 2 for air consumption at rated operating pressure at the trolley motor.

■ Air Lines

The inside diameter of air supply lines must not be smaller than 1/2 in. (13 mm) and 7/16 in. (12 mm) for hose fittings. Before making final connections, all air supply lines should be purged with clean, moisture free air or nitrogen before connecting to unit inlet. Supply lines should be as short and straight as installation conditions will permit. Long transmission lines and excessive use of fittings, elbows, tees, globe valves (etc.) cause a reduction in pressure due to restrictions and surface friction in the lines.

■ Air Line Lubricator (optional feature)

The use of an air line lubricator is optional for Palair, Palair Premium or Liftchain hoists. The trolley motor may be run without in line lubrication, however, accelerated gear wear may be experienced. Use a lubricator having an inlet and outlet size at least as large as the inlet size to the motor. Install the lubricator as close to the air inlet on the trolley motor as possible. The air line lubricator should be replenished daily and set to provide 2 to 3 drops per minute of ISO VG 32 (10W SAE) oil.

■ Air Line Filter

If trolley is to be used in corrosive or moist atmospheres it is recommended that an air line strainer/filter be installed as close as practical to the motor. The strainer/filter should provide 20 micron filtration and include a moisture trap. Clean strainer/filter periodically to maintain its operating efficiency.

■ Moisture in Air Lines

Moisture that reaches the air motor through the supply lines is the chief factor in determining the length of time between service overhauls. Moisture traps can help to eliminate moisture. Other methods, such as an air receiver which collects moisture before it reaches the trolley motor, or an aftercooler at the compressor that cools the air prior to distribution through the supply lines, are also helpful.

■ Motor

For optimum performance and maximum durability of parts, operate the trolley motor within the operating ranges. Refer to Table 2 in the "SPECIFICATIONS" section on page 2.

■ Storing The Trolley

1. Always store the trolley in a no load condition.
2. Wipe off all dirt and water.
3. Oil the hand chain.
4. Place in a dry location.
5. Before returning trolley to service follow instructions for 'Trolleys Not In Regular Use'. Refer to the "INSPECTION" section on page 6.

OPERATION

It is recommended that the user and owner check all appropriate and applicable regulations before placing this product into use. Refer to Product Safety Information Manual.

⚠ WARNING

- The trolley is not designed or suitable for lifting, lowering or moving people. Never lift loads over people.

The trolley operator must be carefully instructed in his or her duties and must understand the operation of the hoist and trolley, including a study of the manufacturer's literature. The operator must thoroughly understand proper methods of hitching loads and should have a good attitude regarding safety. It is the operator's responsibility to refuse to operate the hoist or trolley under unsafe conditions.

■ General Operating Information

Operate the trolley from a position that allows you to observe the load and the intended path of movement of the load.

Do not walk in the path of a moving trolley, or walk backwards when moving a trolley.

Always look in the direction you are moving.

■ Initial Operating Checks

1. After installation, ensure the hoist is centered below the trolley.
2. On powered trolleys, check for air leaks in supply hose and fittings to pendant and trolley motor.
3. Raise a load equal to the lower of the rated capacities of either the trolley or hoist 3 to 4 inches (75 to 100 mm) off the floor.
4. Operate the trolley along the entire length of the beam.
5. Check trolley performance when moving test load(s). Trolley must operate smoothly at rated specifications prior to being placed in service for general use.
6. Check that trolley movement complies with the pendant arrows, on air powered trolley units.

■ Plain Trolley

1. To move an unloaded hoist/trolley, push on the hoist load chain.
2. To move a loaded hoist/trolley, push on the load or the hoist load hook shank.

■ Geared Trolley

Refer to Dwg. MHP0100 on page 8, **A.** Trolley Movement; **B.** Hand Chain Movement. When facing the trolley hand wheel:

1. Pull down on right side of hand chain (clockwise rotation) to move left.
2. Pull down on left side of hand chain (counterclockwise rotation) to move right.

■ Powered Trolley

Direction of trolley travel and speed is controlled by the pendant throttle. Ensure direction arrows on pendant throttle match trolley movement.

■ Pendant Operation

The pendant can have from two to six functions. The two function pendant will control trolley movement along the support beam left to right. A four function pendant will control trolley movement left to right and hoist operation up or down. A six function pendant would include the above movements plus control a bridge assembly allowing hoist movement in four directions. Always apply smooth even pressure to pendant levers/buttons, avoid quick starts and abrupt stops. This will allow safer control of suspended loads and reduce undue stress on components.

Two Function Pendant

Refer to Dwg. MHP1649 on page 8, **A.** Pendant Handle; **B.** Emergency Stop Button; **C.** "ON" Button; **D.** Function Levers; and Dwg. MHP2680 on page 9, **A.** Pendant Handle; **B.** Function Levers.

Four Function Pendant

Refer to Dwg. MHP1547 on page 8, **A.** Emergency Stop Button; **B.** "ON" Button; **C.** Trolley Control Levers; **D.** Pendant Handle; **E.** Hoist Control Levers; and Dwg. MHP2681 on page 9, **A.** Pendant Handle; **D.** Function Levers.

■ Emergency Stop

The emergency stop button, when activated, will immediately stop all operations of the trolley and hoist. The emergency stop button will remain depressed after activation. To reset Emergency Stop button, twist (rotate) emergency stop button clockwise until button releases and spring returns to its original position. Depress "ON" button.

INSPECTION

Inspection information is based in part on American Society of Mechanical Engineers Safety Codes (ASME B30.16).



WARNING

- All new, altered or modified equipment should be inspected and tested by Ingersoll Rand trained Service Technicians to ensure safe operation at rated specifications before placing equipment in service.
- Never use a trolley that inspection indicates is damaged.

Frequent and periodic inspections should be performed on equipment in regular service. Frequent inspections are visual examinations performed by operators or Ingersoll Rand trained inspectors and include observations made during routine equipment operation. Periodic inspections are thorough inspections conducted by Ingersoll Rand trained technicians. ASME B30.16 states inspection intervals depend upon the nature of the critical components of the equipment and the severity of usage. Refer to 'Inspection Classifications' chart and 'Maintenance Intervals' chart in Product Maintenance Information Manual for recommended maintenance intervals. Careful inspection on a regular basis will reveal potentially dangerous conditions while still in the early stages, allowing corrective action to be taken before the condition becomes dangerous.

Deficiencies revealed through inspection, or noted during operation, must be reported to designated personnel to ensure corrective action is taken. A determination as to whether a condition constitutes a safety hazard(s) must be decided, and the correction of noted safety hazard(s) accomplished and documented by written report before placing the equipment in service.

■ Frequent Inspection

On equipment in regular service, a 'Daily Inspection' should be made by the operator at the beginning of each shift and a 'Quarterly Inspection' should be conducted by an Ingersoll Rand trained inspector every 90 days and a record of the inspection maintained.

■ Daily Inspection

Complete inspections prior to start of daily tasks. Conduct visual inspections during regular operation for indications of damage or evidence of malfunction (such as abnormal noises).

1. **Surrounding Area.** Visually check for trolley oil leaks. Do not operate trolley if leaking oil is found. Ensure surrounding area has no slippery surfaces and is obstruction free.
2. **Air System.** (Powered Trolleys only) Visually inspect all connections, fittings, hoses and components for indication of air leaks. Verify hoses are in good condition. Repair any leaks found.
3. **Manual Shut-off Valve.** Test shut-off valve to ensure proper operation and free movement.
4. **Operation.** Operate the trolley so that it travels a few feet (1 metre). During the few feet (1 metre) of travel, check for visual signs or abnormal noises which could indicate wear or damage. Check for smooth operation. Do not operate the trolley until all problems have been corrected.
5. **Controls (Powered Trolleys Only).** During operation of trolley, verify trolley response to pendant use is quick and smooth. Make sure all controls function properly and return to neutral when released. If response is slow or movement is unsatisfactory, do not operate hoist until all problems have been corrected.

6. **Brake (Powered Trolleys Only).** Operate trolley a short distance to test brake. Brake must stop trolley. Brake must release when trolley control is operated. If brake does not stop trolley or release properly, it must be adjusted or repaired.
7. **Lubrication.** Refer to "LUBRICATION" section on page 6 for recommended procedures and lubricants.
8. **Emergency Stop Valve (Powered Trolleys Only).** Activate emergency stop in both directions to ensure proper operation. Valve must stop trolley operation and brake must set quickly. Reset valve after test.

■ Quarterly Inspection

Complete a 'Quarterly Inspection' on a recurring basis to provide regular trolley monitoring.

In addition to the requirements of 'Daily Inspection,' also inspect the following:

1. **Power Supply:**
 - a. Inlet air pressure to the trolley at full throttle with nominal system usage.
 - b. Filter, regulator and lubricator are installed and functioning.
 - c. Air filter is clean, drain if necessary.
 - d. Air supply is set to information in "SPECIFICATIONS" section on page 2.
 - e. Visually check mufflers for restrictions or external damage. Clear restrictions or replace if damaged.
2. **Rigging:**
 - a. Trolley is centered under the beam.
3. **Visual Integrity:**
 - a. All Components - Inspect for wear, damage, distortion, deformation and cleanliness. If external evidence indicates damage, contact an Ingersoll Rand trained technician to disassemble as required to conduct a detailed inspection.
 - b. No part of the trolley has been welded onto.
 - c. Fasteners - Check external retainer rings, split pins, capscrews, nuts and other fasteners on hoist and trolleys.
 - d. Guide Roller - Inspect roller for wear. Ensure roller freely rotates. Replace roller if worn or damaged.
 - e. No modifications have been performed on the trolley.
4. **Labeling / Marking:**
 - a. Data (name) plate is attached and legible.
 - b. Warning tags and labels are attached, legible and in correct places on trolley.
5. **Operational Checks:**
 - a. Limit Switches - Operate trolley in one direction until limit switch engages. Ensure hoist stops operating in that direction, and operates in the opposite direction.
 - b. Operate hoist in opposite direction until limit switch engages. Ensure hoist stops operating in opposite direction, and operates in original direction.

■ Trolleys Not In Regular Use

1. A trolley that has been idle for a period of one month or more, but less than six months, shall be given an inspection conforming with the requirements of 'Frequent Inspection' before being placed into service.
2. A trolley that has been idle for a period of over six months shall be given a complete inspection conforming with the requirements of 'Periodic Inspection' before being placed into service. Refer to Product Maintenance Information Manual.

LUBRICATION

To ensure continued satisfactory operation of the trolley, all points requiring lubrication must be serviced with correct lubricant at the proper time interval as indicated for each assembly.

Lubrication intervals recommended in this manual are based on intermittent operation of trolley, eight hours each day, five days per week. If trolley is operated almost continuously or more than eight hours each day, more frequent lubrication will be required. Also, lubricant types and change intervals are based on operation in an environment relatively free of dust, moisture, and corrosive fumes. Use only those lubricants recommended. Other lubricants may affect performance of trolley. Approval for the use of other lubricants must be obtained from your Ingersoll Rand Technical Support Department. Failure to observe this precaution may result in damage to the hoist and/or its associated components.

Table 3: Lubrication Intervals

INTERVAL	LUBRICATION CHECKS
Start of each shift	If used, check flow and level of air line lubricator (approximately 2 to 3 drops per minute required at maximum motor speed).
Monthly	Lubricate components supplied by grease fittings. Inspect and clean or replace air line filter.
2 Years	Drain and refill trolley reduction gear oil.

■ Trolley Wheel Bearings

The trolley wheel bearings are sealed and permanently lubricated. They do not require additional lubrication. However, should the trolley wheels be disassembled for inspection or repair, repack the trolley wheel bearings. Refer to Table 4 'Trolley Recommended Lubricates' on page 7.

■ Geared Trolley Wheels and Pinion Shaft

Lubricate exposed trolley drive pinion and wheel teeth. Brush with grease as often as necessary to keep teeth liberally covered. If the grease becomes contaminated with sand, dirt or other abrasive materials, clean off old grease and brush on new. For temperatures use grease or equivalent. Refer to Table 4 'Trolley Recommended Lubricants' on page 7.

⚠ CAUTION

- When greasing pinion and geared wheels make sure excess grease is cleaned off trolley wheel riding surface and track or beam. Failure to keep beam and wheel contact surfaces clean could affect the safe operation of the trolley.

Table 4: Trolley Recommended Lubrication

Temperature	Recommended Viscosity
-20° to 50° F (-29° to 10° C)	ISO VG 46 (EP1)
30° to 120° F (-1° to 49° C)	ISO VG 68* (20W SAE)

■ Trolley Rack Gear and Pinion (optional)

Lubricate exposed trolley drive pinion and rack gear teeth. Brush with grease as often as necessary to keep teeth liberally covered. If the grease becomes contaminated with sand, dirt or other abrasive materials, clean off old grease and brush on new. Refer to Table 4 'Trolley Recommended Lubrication' on page 7.

⚠ CAUTION

- When greasing pinion and rack gear teeth, make sure excess grease does not get on trolley wheel surfaces. Failure to keep beam and wheel contact surfaces clean could affect the safe operation of the trolley.

■ Air Motor

The trolley motor may be operated without in-line lubrication. If a lubricator is used it should be checked/replenished daily and set to provide 2 to 3 drops per minute at full throttle of high quality rust and oxidation inhibited lubricant ISO VG 32 (10W SAE). Refer to "ACCESSORIES" section in Product Parts Information Manual for lubricator and air filter information.

⚠ CAUTION

- Shut off air supply before filling air line lubricator.

■ Hand Chain

Hand chain, used on geared trolleys, normally requires no lubrication.

■ Reduction Gearbox

4 ton

The reduction gearbox is shipped from the factory with the correct amount of grease. No further lubrication is required. If the reduction gearbox is disassembled during routine maintenance replace old grease. Refer to Table 4 'Trolley Recommended Lubrication' on page 7.

8 to 25 ton

The reduction gearbox and disc brake are filled with oil, to the correct level, prior to shipment. Check oil level before initial operation. These components are splash lubricated by the oil in the housing and have no other means of lubrication. It is therefore important to use high quality, rust and oxidation inhibited lubricant. Oil capacity is approximately 8 fl. oz. (250 ml).

4 ton Rack Drive (option)

The reduction gearbox is lubricated with grease during assembly and does not require regular lubrication.

■ Initial Reduction Gearbox Assembly Oil Change

It is recommended that the first oil change be done after approximately 50 hours of initial operation. Always inspect removed oil for evidence of internal damage (metal shavings, dirt, water, etc.)

NOTICE

- Always collect lubricants in suitable containers and dispose of in an environmentally friendly manner.

■ Reduction Gearbox Drain and Fill

8 and 12.5 ton

Refer to Dwg. MHP3073 on page 9, A. Fill and Drain Plug. Reduction gearbox must be drained and filled through the same port.

25 ton

Refer to Dwg. MHP3072 on page 9, A. Fill Plug; B. Drain Plug.

To Drain

1. Place container under reduction gear drain plug and remove plug.
2. Remove fill plug, if provided.

To Fill

1. Insert drain plug and tighten. (25 ton only)
2. Fill slowly until oil is level with fill plug. Refer to Table 5 'Reduction Gearbox Recommended Lubricants' on page 7.
3. Install fill plug and tighten.

Rack Drive (optional) 8 to 25 ton

To Drain

1. Place container under reduction gear drain plug and remove plug.
2. Remove level/fill plug.

To Fill

1. Insert drain plug and tighten.
2. Fill slowly until oil is level with fill plug. Refer to Table 5 'Reduction Gearbox Recommended Lubricants' on page 7.

Table 5: Reduction Gearbox Recommended Lubricants

Temperature	Recommended Viscosity
Below 32° F (0° C)	ISO VG 32 (10W SAE)
32° to 80° F (0° to 27° C)	ISO VG 68* (20W SAE)
Above 80° F (27° C)	ISO VG 100 (30W SAE)
TD-20° Option	Synthetic Oil **

* Unit is shipped with this lubricant.

** Use Mobile Gear 626 or equivalent synthetic oil.

PRODUCT INFORMATION GRAPHICS

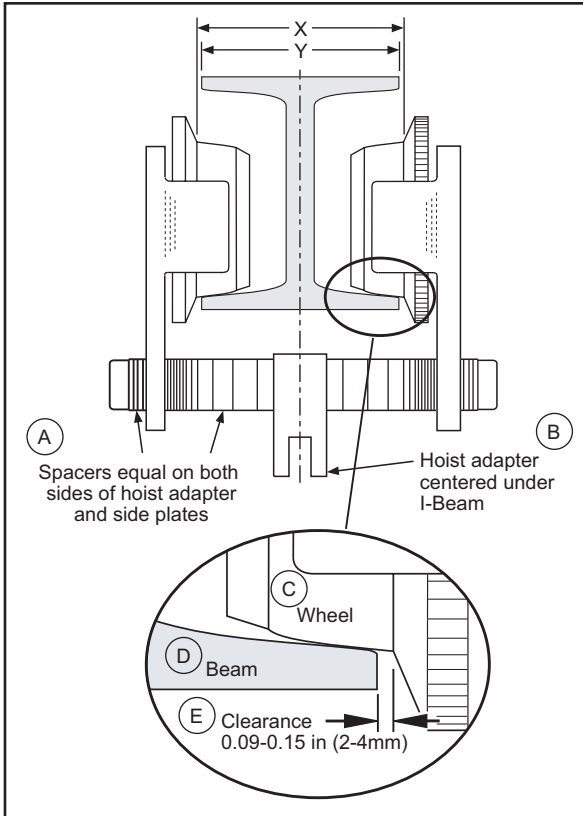

(Dwg. MHP1537)

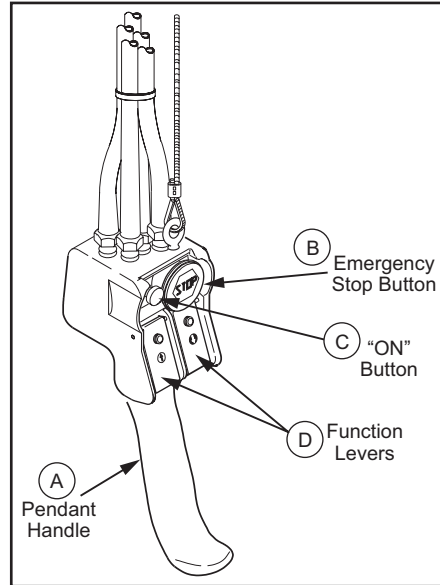

(Dwg. MHP1649)

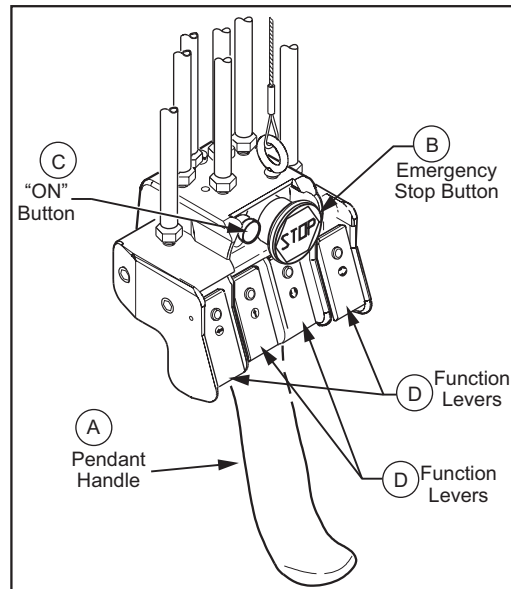

(Dwg. MHP1547)

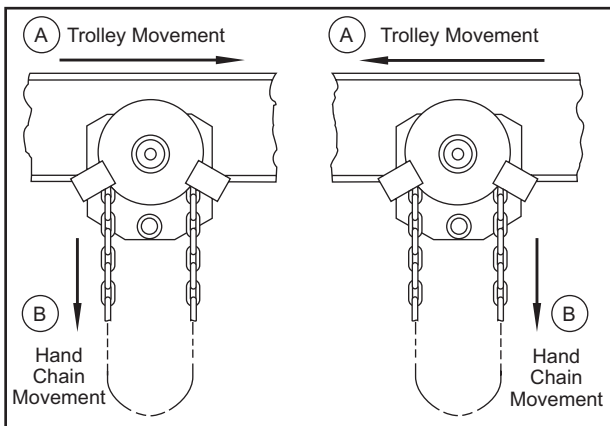

(Dwg. MHP0100)

PRODUCT INFORMATION GRAPHICS CONTINUED

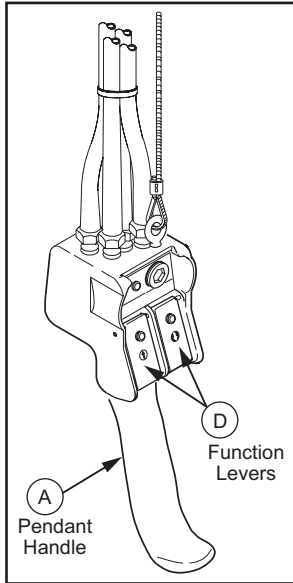

(Dwg. MHP2680)

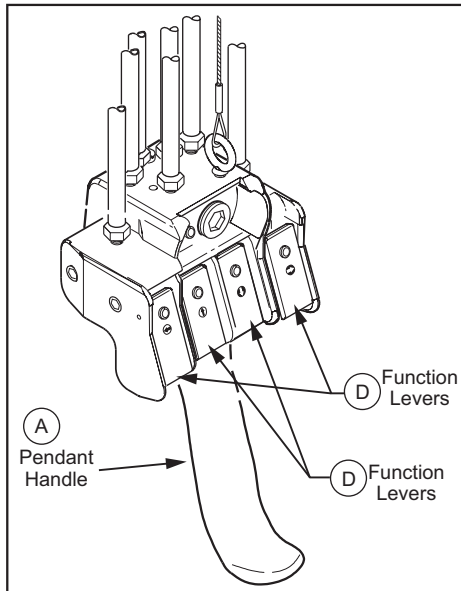

(Dwg. MHP2681)

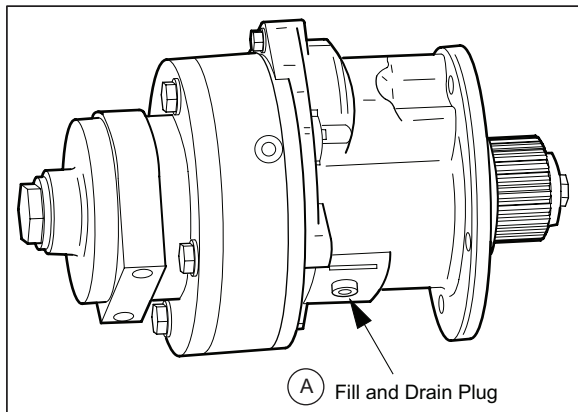

(Dwg. MHP3073)

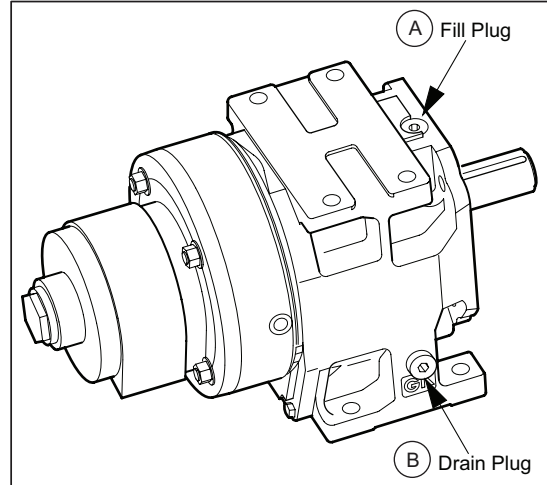

(Dwg. MHP3072)

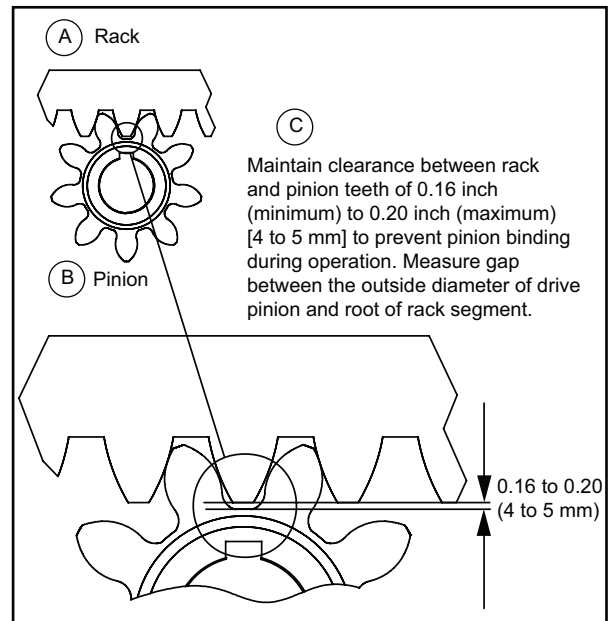

(Dwg. MHP2990)

PRODUCT INFORMATION GRAPHICS CONTINUED

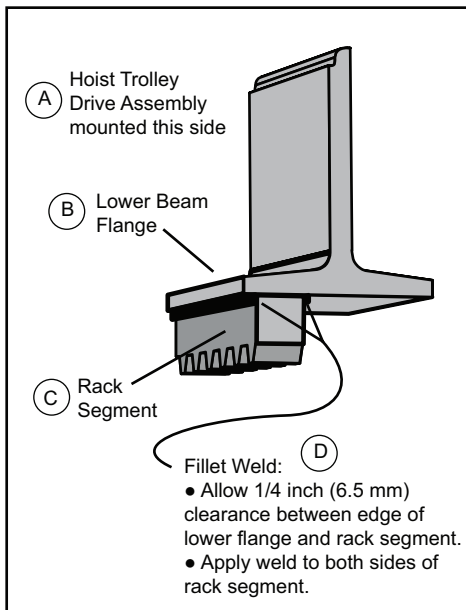
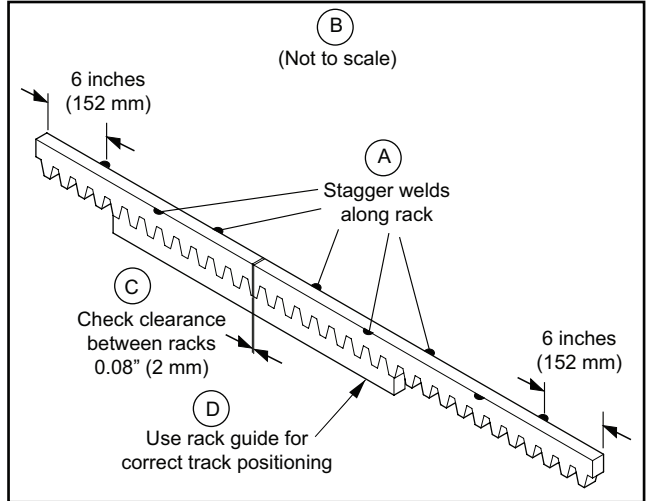
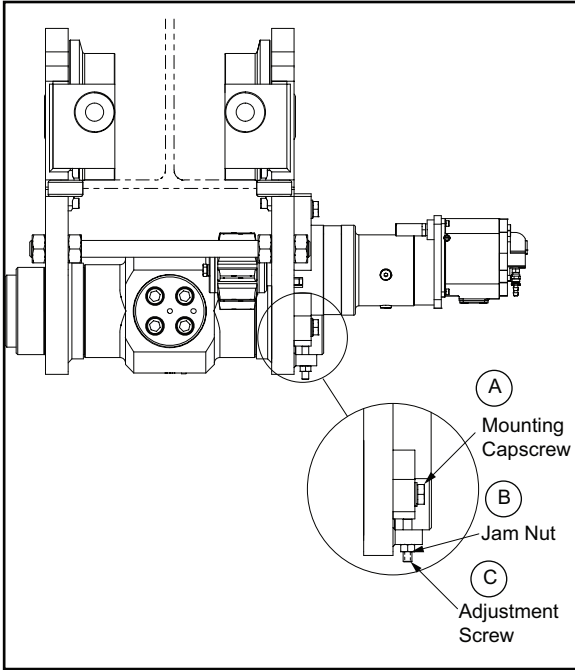

DECLARATION OF CONFORMITY



(CS) PROHLÁŠENÍ O SHODĚ (DA) FABRIKATIONSERKLÆRING (DE) KONFORMITÄTSEKTLÄRUNG (EL) ΔΗΛΩΣΗ ΑΝΑΓΝΩΡΙΣΗΣ (ES) DECLARACIÓN DE CONFORMIDAD (FI) VAKUUTUS NORMIEN TÄYTTÄMISESTÄ (FR) CERTIFICAT DE CONFORMITÉ (HU) MEGFELELŐSÉGI NYILATKOZAT (IT) DICHIARAZIONE DI CONFORMITÀ (NL) SCHRIFTELIJKE VERKLARING VAN CONFORMITEIT (NO) KONFORMITETSEKTLÆRING (PT) DECLARAÇÃO DE CONFORMIDADE (PL) DEKLARACJA ZGODNOŚCI (SK) PREHLÁSENIE O ZHODE (SL) IZJAVA O SKLADNOSTI (SV) FÖRSÄKRAN OM ÖVERENSSTÄMMELE

Ingersoll-Rand

529, Avenue Roger Salengro, 59450 Sin Le Noble, France

Declare under our sole responsibility that the product: Plain, Hand Chain (Geared) and Air Powered Trolleys

(CS) Prohlašujeme na svou zodpovědnost, že produkt: pneumatický kladkostroj (DA) Erklærer som eneansvarlig, at nedenstående produkt: Pneumatisk lift (DE) Erklären hiermit, gemäß unserer alleinigen Verantwortung, daß die Geräte: Druckluft-Kettenzug (EL) Δηλώνουμε ότι με δική μας ευθύνη το προϊόν: Πνευματικός ανυψωτήρας (ES) Declaramos que, bajo nuestra responsabilidad exclusiva, el producto: Polipasto neumático (FI) Vakuutamme ja kannamme yksin täyden vastuun siitä, että tuote: Paineilmanostin (FR) Déclarons sous notre seule responsabilité que le produit: Palans pneumatiques (HU) Kizárólagos felelősségünk tudatában kijelentjük, hogy a termék: Pneumatikus emelő (IT) Dichiariamo sotto la nostra unica responsabilità che il prodotto: Paranco pneumatico (NL) Verklaren, onder onze uitsluitende aansprakelijkheid, dat het product: Pneumatische takel (NO) Erklærer på ære og samvittighet at produktet: Pneumatisk talje (PL) Przyjmując pełną odpowiedzialność, oświadczamy, że produkt: Wciągnik pneumatyczny (PT) Declaramos sob a nossa exclusiva responsabilidade que o produto: Guincho Pneumático (SK) Závazne prehlasujeme, že výrobok: pneumatický kladkostroj (SL) Pod polno odgovornostjo izjavljamo, da je izdelek: Pnevmatško dvigalo (SV) Intygat enligt vårt ansvar att produkten: Tryckluftsdrevena lyftdon

Model: TR2U015()-E, TR2U040()-E, TR2U80()-E, TR2U120()-E and TR2U250()-E / Serial Number Range: 03-01-XX and up (i.e.: Year-Month-Chronological Number)

(CS) Model: / Rozsah výrobních čísel: (DA) Model: / Seriennummerområde: (DE) Modell: / Seriennummernbereich: (EL) Μοντέλο: / Κλίμακα σειριακών αριθμών: (ES) Modelo: / Números de serie: (FI) Malli: / Sarjanumeroalue: (FR) Modèle: / Gamme de numéros de série: (HU) Modell: / Gyártási szám-tartomány: (IT) Modello: / Gamma delle matricole: (NL) Model: / Seriennummer: (NO) Modell: / Serien: (PL) Model: / Zakres numerów serii: (PT) Modelo: / Gama de Nos de Série: (SK) Model: / Rozsah výrobných čísiel: (SL) Model: / Območje serijskih števil: (SV) Modell: / Seriennummer, mellan:

To which this declaration relates, is in compliance with provisions of Directive(s): 98/37/EC (machinery), 94/9/EC (ATEX)

(CS) Ke kterým se toto prohlášení vztahuje, odpovídají ustanovením směrnic: (DA) som denne erklæring vedrører, overholder bestemmelserne i følgende direktiv(er): (DE) auf das sich diese Erklärung bezieht, der folgenden Richtlinie entspricht: (EL) στο οποίο αναφέρεται αυτή η δήλωση, πληροί τις διατάξεις της Οδηγίας: (ES) a los que se refiere la presente declaración, cumplen con todo lo establecido en las directivas: (FI) johon tämä vakuutus viittaa, täyttää direktiiveissä: (FR) Objet de ce certificat, est conforme aux prescriptions des Directives: (HU) Amelyekre ezen nyilatkozat vonatkozik, megfelelnek a következő irányelvek előírásainak: (IT) a cui si riferisce la presente dichiarazione è conforme alle normative delle direttive: (NL) waarop deze verklaring betrekking heeft overeenkomt met de bepalingen van directieven: (NO) som denne erklæringen gjelder for, oppfyller bestemmelsene i direktivene: (PL) Którego dotyczy niniejsza deklaracja, jest zgodny z wymogami dyrektyw: (PT) Ao qual se refere a presente declaração, está de acordo com as prescrições das Directiva: (SK) Na ktorý sa toto prehlásenie vzťahuje, je v súlade s ustanoveniami Smernice (Smerníc): (SL) Na katerega se ta izjava o skladnosti nanaša, v skladu z določili smernic: (SV) Som detta intyg avser, överensstämmer med följande direktiv:

By using the following Principle Standards: EN 292-1; EN 292-2; EN 418; EN 983; F.E.M. 1.001; F.E.M. 9.511; EN 13463-1; pr EN 13463-5; EN 1127-1

(CS) Použitím následujících zákonných norem: (DA) ved at være i overensstemmelse med følgende hovedstandard(er): (DE) Unter Anlehnung an die folgenden Grundnormen entsprechen: (EL) Χρησιμοποιώντας τα παρακάτω κύρια πρότυπα: (ES) conforme a los siguientes estándares: (FI) esitetty vaatimukset seuraavia perusnormeja käytettäessä: (FR) En observant les normes de principe suivantes: (HU) A következő elvi szabványok alkalmazása mellett: (IT) Seguendo i principi standard indicati di seguito: (NL) overeenkomstig de volgende hoofdstandaards: (NO) Ved å bruke følgende prinsipielle standarder: (PL) Spełniając wymogi następujących głównych norm: (PT) observando as seguintes Normas Principais: (SK) Pri dodržaní nasledovných noriem: (SL) Uporabljeni osnovni standardi: (SV) Genom att använda följande principstandard:

Date: February, 2004

(CS) Datum: Únor 2004: (DA) Dato: Februar, 2004: (DE) Datum: Februar, 2004: (EL) Ημερομηνία: Φεβρουάριος, 2004: (ES) Fecha: Febrero, 2004: (FI) Päiväys: Helmikuu, 2004: (FR) Date: Février, 2004: (HU) Dátum: 2004 Február: (IT) Data: Febbraio, 2004: (NO) Dato: Februar, 2004: (NL) Datum: Februari, 2004: (PT) Data: Fevereiro, 2004: (PL) Data: luty 2004: (SK) Dátum: Február 2004: (SL) Datum: februar 2004 (SV) Datum: Februari, 2004:

Approved By:

(CS) Schválil: (DA) Godkendt af: (DE) Genehmigt von: (EL) Εγκρίθηκε από: (ES) Aprobado por: (FI) Hyväksytty: (FR) Approuvé par: (HU) Jóváhagyta: (IT) Approvato da: (NL) Goedgekeurd door: (NO) Godkjent av: (PL) Zatwierdzona przez: (PT) Aprovado por: (SK) Schválil: (SL) Odobril: (SV) Godkänt av:

Jean-Luc Faillon - IREP - Douai, France

Engineering Product Manager

