



**FINISH THOMPSON INC.**

# **PF SERIES PUMPS**

## **PFS OPERATION & PARTS MANUAL** *For Serial Number 162858 & lower*





**FINISH THOMPSON INC.**

921 Greengarden Road • Erie, PA 16501-1591 U.S.A.  
Ph 814-455-4478 • Fax 814-455-8518  
Email [fti@finishthompson.com](mailto:fti@finishthompson.com) • [www.finishthompson.com](http://www.finishthompson.com)

## EU Declaration of Conformity



Finish Thompson Inc. hereby declares that the following machine(s) fully comply with the applicable health and safety requirements as specified by the EC Directives listed. The product may not be taken into service until it has been established that the drive motor for the Drum and Container Pump complies with the provisions of all relevant EC Directives. The complete product complies with the provisions of the EC Directive on machinery safety provided motors manufactured by Finish Thompson Inc. are used.

This declaration is valid provided that the devices are fully assembled and no modifications are made to these devices.

### Type of Device:

Drum and Container Pump Tubes

### Models:

BTS - 40  
HVDP LR-27/40/48  
PFP-15/27/40/48/60/72  
TBP-27/40/48  
STTS-40

EPPI/EPSS 15/27/40  
HVDP HR-27/40/28  
PFS-27/40/48/60/72  
TBS-40  
TMS-40

EFP/EFV/EFS-16/27/40/48  
PFM-27/40/48/60  
PFV-27/40/48/60/72  
TTC/TTS-27/40/48

### EC Directives:

Machinery Safety (2006/42/EC)

### Applied Harmonized Standards:

EN ISO 12100 Part 1  
EN ISO 12100 Part 2  
EN 809

Manufacturer: Finish  
Thompson Inc.  
921 Greengarden Road  
Erie, Pennsylvania 16501-1591 U.S.A

Signed,

President

27 February 2015

Person(s) Authorized to Compile Technical File: Finish Thompson GmbH  
Otto-Hahn-Strasse 16  
Maintal, D-63477 DEU  
Telephone: 49 (0)6181-90878-0

## Introduction

This manual pertains to the PF Series, specifically the PFS stainless steel drum pump. Finish Thompson Inc. thanks you for choosing our products. We believe the use of our products will be fully satisfactory. When properly installed and operated, your Finish Thompson motor and pump will provide long, trouble-free service; therefore, please read this manual carefully before carrying out any operations on the pump/motor unit. Any use other than that described herein is considered incorrect; and, consequently, Finish Thompson Inc. shall not be held responsible for any damages to people or property. In case of doubt or enquiries, please reply to our Technical Service department directly at the following address:

Finish Thompson, Inc.  
 921 Greengarden Rd.  
 Erie, PA 16501 U.S.A.  
 Tel. 1-814-455-4478; Fax 1-814-455-8518  
[www.finishthompson.com](http://www.finishthompson.com); [fti@finishthompson.com](mailto:fti@finishthompson.com)

## Index

Introduction .....	1
Pump Specifications .....	1
Warranty, General Terms & Conditions.....	2
Safety .....	3
Installation.....	4
Maintenance	
Disassembly .....	4
Inspection .....	4
Reassembly .....	5
Exploded View .....	6
Pump Tube Spare Parts List .....	7-8

**Technical Service Hotline:** 1-800-888-3743 or email [techservice@finishthompson.com](mailto:techservice@finishthompson.com)

<b>PUMP SPECIFICATIONS</b>	
	<b>MODEL PFS</b>
Outer Tube Diameter	2" (51 mm)
Discharge Type	1" hose barb
Max. Specific Gravity	1.83
Max. Viscosity	2000 cP
Min./ Max. Fluid Temperature	-20°F (5° F with Perlast o-rings) Min. to 220° F Max. [-4° C (21° C) Min. to 105° C Max.]
Wetted Materials	316 Stainless Steel, FKM, PTFE, ETFE

# Warranty, General Terms & Conditions

1. The following terms and conditions apply to the sale of machinery, components and related services and products, of Finish Thompson Inc. (hereinafter “the products”)
2. Finish Thompson Inc. (the manufacturer) warrants only that:
  - a) its products are free of defects in material, design and workmanship at the time of original purchase;
  - b) its products will function in accordance with Finish Thompson Inc. operation manuals; Finish Thompson Inc. does not guarantee that the product will meet the precise needs of the Customer, except for those purposes set out in any invitation to render documents or other documents specifically made available to Finish Thompson Inc. before entering into this agreement;
  - c) high quality materials are used in the construction of the pumps and that machining and assembly are carried out to the highest standards. Except as expressly stated above, Finish Thompson Inc. makes no warranties, express or implied, concerning the products, including all warranties of fitness for a particular purpose.

This warranty shall not be applicable in circumstances other than defects in material, design, and workmanship. In particular warranty shall not cover the following:

- d) Periodic checks, maintenance, repair and replacement of parts due to normal wear and tear;
- e) Damage to the product resulting from:
  - i. Tampering with, abuse or misuse, including but not limited to failure to use the product for its normal purposes as stated at the time of purchase or in accordance with Finish Thompson, Inc. instructions for use and maintenance of the product, or the installation or improper ventilation or use of the product in a manner inconsistent with the technical or safety standard in force;
  - ii. Repairs performed by non-authorized service workshop, or opening of the unit by non-authorized personnel, or use of non genuine Finish Thompson Inc. parts;
  - iii. Accidents, force majeure or any cause beyond the control of Finish Thompson Inc., including but not limited to lightning, water, fire, earthquake, and public disturbances, etc.
3. The warranty shall cover the replacement or repair of any part, which is documented to be faulty due to construction or assembling, with new or repaired parts free of charge delivered by Finish Thompson, Inc. Parts subjected to normal wear and tear shall not be covered by the warranty. Finish Thompson, Inc. shall decide as to whether the defective or faulty part shall be replaced or repaired. Transportation charges are prepaid to Finish Thompson.
4. The warranty of the products shall be valid for a period of **12 months** from the date of delivery, under the condition that notice of the alleged defect to the products or parts thereof be given to Finish Thompson, Inc. within the term of 8 days from the discovery.
5. Repair or replacement under the terms of this warranty shall not give a right to an extension to, or a new commencement of, the period of warranty. Repair or replacement under the terms of this warranty may be fulfilled with functionally equivalent re-conditioned units. Finish Thompson Inc. qualified personnel shall be solely entitled to carry out repair or replacement of faulty parts after careful examination of the motor. Faulty parts or components when replaced by Finish Thompson Inc. will become the property of Finish Thompson Inc. If this warranty does not apply, the purchaser shall bear all cost for labor, material and transportation.
6. Finish Thompson Inc. will not be liable on any claim, whether in contract, tort, or otherwise, for any indirect, special, incidental, or consequential damages, caused to the customer or to third parties, including loss of profits, process down time, transportation costs, costs associated with replacement or substitution products, labor costs, installation or removal costs. In any and all events, manufacturer’s liability shall not exceed the purchase price of the product and/or accessories.
7. **Return Policy.** Should you have any problems with this product, please contact the distributor in your area. The distributor will determine if a return to the factory is necessary and will contact the factory for a Return Authorization Number. Otherwise, contact our Technical Service Hotline (1-800-888-3743) or e-mail [techservice@finishthompson.com](mailto:techservice@finishthompson.com) if you have any questions regarding product operation or repair.

# Safety

## 1. Introduction

This manual contains all the information needed for the correct installation, use and maintenance of your new Finish Thompson pump. It should be read and understood by all the personnel involved in installation, operating and servicing of the pump before it is started.

## 2. Operator Qualification and Training

The personnel in charge of the installation, the operation, and the maintenance of the pump must be qualified and able to perform the operations described in this manual. Finish Thompson, Inc. shall not be held responsible for the training level of personnel and for the fact that they are not fully aware of the contents of this manual.

## 3. Safety Instructions

### **FOR YOUR OWN SAFETY**

**BEFORE** using or servicing your pump, please make sure to wear the proper clothing, eye protection and follow standard safety procedures when handling corrosive or personally harmful materials.

### **GENERAL DANGER**

**ALWAYS** use a stainless steel pump tube with an explosion proof electric motor or air motor and static protection kit with grounded discharge hose when pumping or mixing flammable or combustible material.

**NEVER** use in pressurized containers.

**ALWAYS** store unit upright, i.e. motor above pump, and away from corrosive liquids and vapors.

### **DANGER: POWER SUPPLY**

Refer to instructions for the appropriate motor in the Operation & Installation Manual - Drum Pump Motors.

## 4. Noise Level

Refer to specifications in the Operation & Installation Manual - Drum Pump Motors.

## 5. Modifications and Spare Parts

Any changes concerning the service of the pump as originally purchased can be executed only after written approval from Finish Thompson Inc. It is recommended to use only genuine Finish Thompson Inc. spare parts and approved accessories. The use of non-original spare parts or non-approved accessories will void warranty and removes any responsibility on the manufacturer's behalf for any damage caused to people or things.

# Installation & Maintenance Instructions

## Installation

1. Remove the drum pump and motor from its packaging and inspect for shipping damage.
2. Turn the pump coupling to verify there is no binding. Verify the housing cover (item 16) is on tight (it has a left hand thread).
3. Adjust the coupling so that the empty slots in the insert are at 3 and 9 o'clock with the pump discharge at 12 o'clock.
4. Install the motor according to instructions in the appropriate motor manual.
5. Attach 1" i.d. discharge hose and secure with hose clamp.
6. Install into the container.

## Maintenance

### Disassembly

1. Remove the housing cover (item 16) by turning it clockwise (left hand thread) while gripping the impeller housing (item 13).
2. Turn the impeller until a hole in the shaft can be seen through the square slot in the impeller housing (item 13), and insert 3/32 pin into the hole. Holding the pin, turn the impeller (item 15) counterclockwise (right-hand thread) and remove it.
3. Remove the impeller housing (item 13) by gripping the intake tube and turning the housing clockwise (left hand thread).
4. Place a wooden board or rubber mat on the floor (to protect the threads on the bottom of the shaft) and gently tap the shaft (item 14) on it until the inner tube (item 9), shaft sleeve (item 10), and bottom bearing (item 3) drops out. Continue to tap the shaft until both bearings (item 3) are exposed at the top of the pump.
5. Pull the bearings and shaft out through the top of the pump.

### Inspection

1. Check the housing cover (item 16), the impeller (item 15), and the impeller housing (item 13) for wear, rubbing, or damage from foreign objects. Replace if damaged.  
**Note:** The double impeller design of this pump is dependant on the impeller working correctly. Any damage to the impeller can cause pump failure.
2. Inspect the pump shaft (item 14) for wear in the bearing (item 11) and the lip seal (item 4) areas. Replace the shaft if needed.
3. Inspect the bottom bearing (item 11) for internal wear. Inspect all o-rings (items 8 & 12) for nicks or chemical attack. Replace as needed.
4. Inspect the bearing assembly (item 3) for rust or corrosion.
5. If the bearing assembly needs to be replaced, unthread it from the shaft. Insert 3/32" pin into the hole at the bottom and hold the bearing assembly by the half coupling. Turn the shaft counterclockwise (right hand thread) to loosen and remove. If corroded, then a penetrating fluid may be used on the threads to help loosen.  
**Note:** Never reuse the lip seal.

## Reassembly

1. Install new lip seal (item 4) into the pump head with the grooved side facing the bottom of the pump.
2. If bearing assembly is replaced -- thread the shaft (item 14) into the bearing assembly (item 3) with the 3/32 hole in the shaft on the other end. Carefully insert the shaft straight through the lip seal (to avoid seal damage) from the top and seat the bearing assembly (item 3) into the pump head.
3. If o-rings are replaced -- install 2 inner tube o-rings (item 8) in the grooves. Install the impeller housing o-ring (item 12) inside the top of the housing. Apply a small amount of Vaseline to the o-rings to aid in assembly.
4. With the pump on a bench, slide shaft liner (item 10) into the inner tube (item 9) assembly onto the shaft until it stops. Slide the shaft liner/inner tube/shaft assembly into the outer tube (item 7) using the shaft (item 14) as a guide.
5. Slide the impeller housing over the shaft, center the bottom of the lower inner tube into the counter bore in the top of the impeller housing, and push / thread into the intake tube bottom (left hand thread).
6. Gripping the coupling at the top of the pump, thread the impeller on (right hand thread). Install the housing cover (left hand thread). turn the coupling to verify there is no binding inside the pump.

# PFS SPARE PARTS EXPLODED VIEW

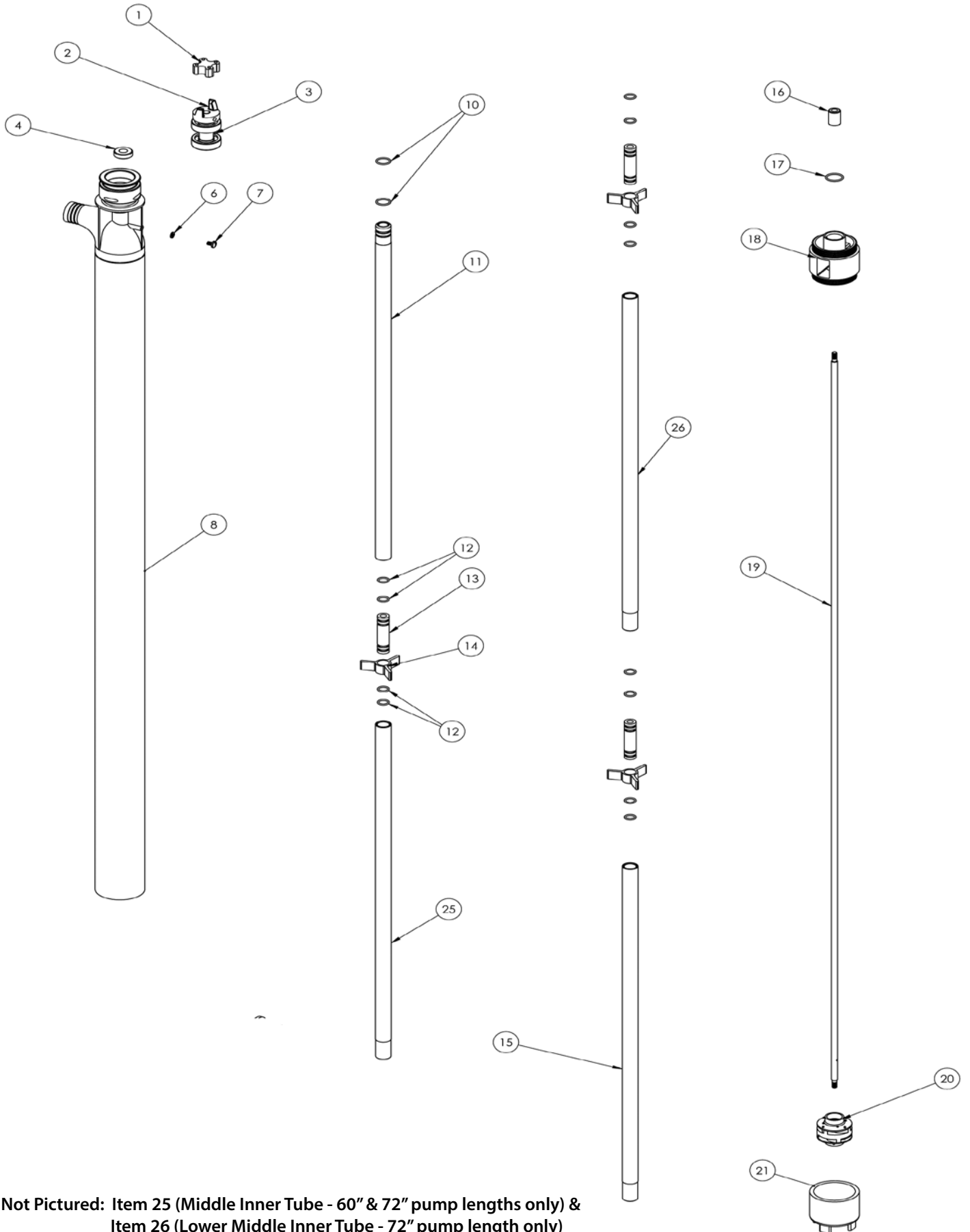

Not Pictured: Item 25 (Middle Inner Tube - 60" & 72" pump lengths only) & Item 26 (Lower Middle Inner Tube - 72" pump length only)

**PUMP SPARE PARTS LIST**  
(for serial numbers 162858 and lower)

ITEM	QTY	DESCRIPTION	PART NUMBER
1	1	<b>COUPLING INSERT</b>	
			J100014
2	1	<b>COUPLING HALF</b>	
			J100012
3*	1	<b>BEARING ASSEMBLY</b>	
			A101110
4*	1	<b>VAPOR SEAL</b>	
			M100008
6	1	<b>LOCK WASHER</b>	
		#8 BRASS	J100823
7	1	<b>SCREW</b>	
		#8-32 X 1/4 BRASS PAN HEAD	J100822
8	1	<b>INTAKE TUBE ASSEMBLY</b>	
		27" MODELS	A101725-1
		40" MODELS	A101725-3
		48" MODELS	A101725-4
		60" MODELS	A101725-5
		72" MODELS	A101725-6
10*	2	<b>INNER TUBE O-RING</b>	
		FKM	J100249
		EPDM	106519
		PERLAST	105621
11	1	<b>STAINLESS STEEL UPPER INNER TUBE</b>	
		27" MODELS	M100786-1
		40" MODELS	M100786-3
		48" MODELS	M100786-4
		60" MODELS	M100786-3
		72" MODELS	M100786-3
12*	1	<b>CENTER BEARING O-RING</b>	
		FKM	J100018
		EPDM	106798
		PERLAST	105620
13*	1	<b>CENTER BEARING</b>	
		PTFE	M100010
14*	1	<b>BEARING GUIDE</b>	
		PTFE	M101603-3
15	1	<b>LOWER INNER TUBE</b>	
		27" MODELS	M100789-1
		40" MODELS	M100789-3
		48" MODELS	M100789-4
		60" MODELS	M100789-3
		72" MODELS	M100789-3
16*	1	<b>BOTTOM BEARING</b>	
		PTFE	M100007
17	1	<b>IMPELLER HOUSING O-RING</b>	
		FKM	J100019
		EPDM	106799
		PERLAST	105622
18†	1	<b>IMPELLER HOUSING (sold as a kit with Item 21)</b>	
		Stainless steel	108131
19	1	<b>SHAFT</b>	
		27" MODELS	M100004-5
		40" MODELS	M100004-7
		48" MODELS	M100004-8
		60" MODELS	M100004-12
		72" MODELS	M100004-13
20*	1	<b>PFS IMPELLER ASSEMBLY</b>	
			A100002-3

21 <sup>†</sup>	1	<b>PFS HOUSING COVER (sold as a kit with Item 18)</b>	
			See Item 18
25		<b>UPPER MIDDLE INNER TUBE</b>	
		27" MODELS	N/A
		40" MODELS	N/A
		48" MODELS	N/A
		60" MODELS	M100789-3
		72" MODELS	M100789-3
26	1	<b>LOWER MIDDLE INNER TUBE</b>	
			M100789-1

\*Recommended Spare Parts

<sup>†</sup>If replacing either item number 18 or 21, you must order both to assure proper fit.

**Note:** Bearing assembly and vapor seal can be purchased as a kit using part number 106567.



**FINISH THOMPSON INC.**

Rev. 1, 3-5-13  
Service 1-800-888-3743