



# Liftchain Hook Mount Air Chain Hoist

1.5-100 ton

**All steel construction**  
for better durability

**Fully enclosed, automatic multi disc brake** for corrosion resistance

**Pneumatic great motor**

**Integrated upper and lower limit switches** for better protection

**Corrosion resistant grade 80 load chain**

**Water drain holes** to prevent water from being trapped in the block and corroding

**Ball bearing mounted bottom hook** for easier, smoother turning under load

**Ergonomic pendant control**

Ideal for:



Shipbuilding



Metals



Heavy Construction

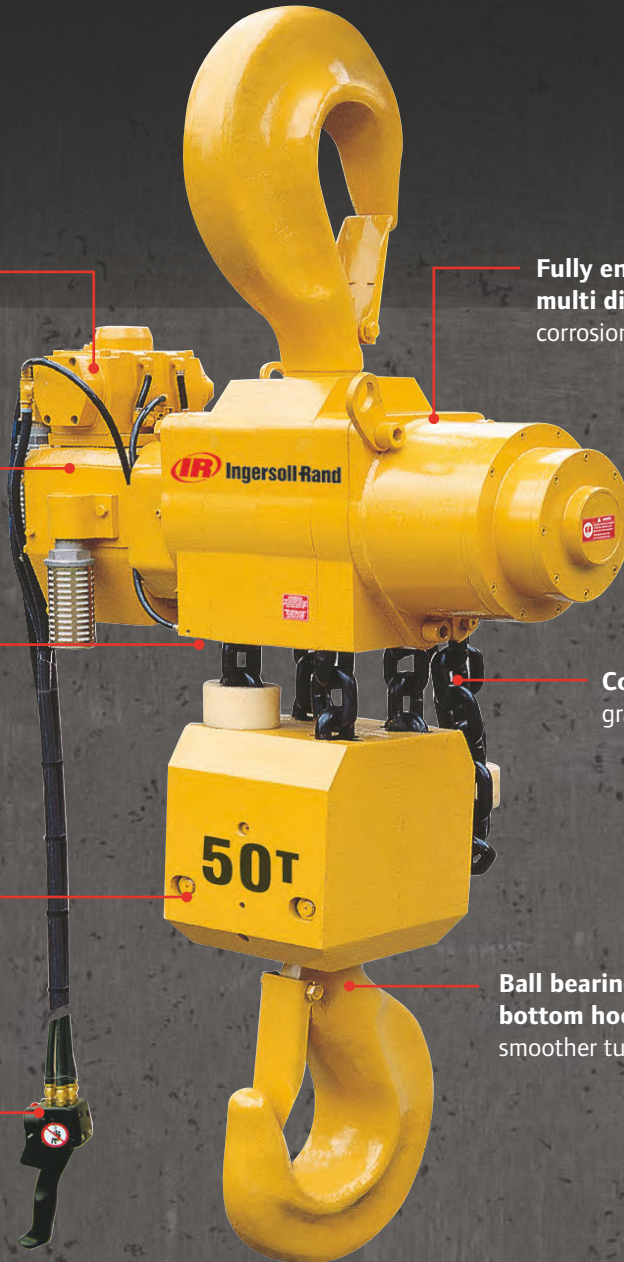



# Liftchain Hook Mount Air Chain Hoist

1.5-100 ton

Ingersoll Rand Liftchain Hoists are the most advanced heavy-lifting hoists in the Ingersoll Rand hoist line. They incorporate all the best features we've developed from our decades of experience into a compact, modular frame. Hook Mount versions offer maximum versatility to place them where you need them. Count on Liftchain hook mount hoists to get the job done.

General Characteristics					
Model	Lifting Capacity Metric Tons	Reeves of Chain	Headroom mm (in)	Hoist Weight with 3m (10ft) of chain kg (lb)	Weight per additional meter of lift kg (lb)
LC2A015SI	1.5	1	409 (16.1)	38 (84)	1.5 (3.3)
LC2A030DI	3	2	549 (21.6)	48 (106)	3.0 (6.6)
LC2A040SI	4	1	580 (22.8)	90 (198)	3.8 (8.4)
LC2A060QI	6	4	653 (25.7)	74 (163)	6.0 (13.2)
LC2A060SI	6	1	717 (28.2)	125 (276)	5.7 (12.6)
LC2A080DI	8	2	807 (31.8)	118 (260)	7.6 (16.8)
LC2A120DI	12	2	945 (37.2)	170 (375)	11.4 (25.1)
LC2A125SI	12.5	1	865 (34.1)	395 (871)	10.7 (23.6)
LC2A180TI	18	3	1063 (41.9)	277 (611)	17.1 (37.7)
LC2A250QI	25	4	1156 (45.5)	324 (714)	23.0 (50.7)
LC2A250DI	25	2	1235 (48.6)	558 (1,230)	21.4 (47.2)
LC2A375TI	37.5	3	1484 (58.4)	855 (1,885)	32.1 (70.8)
LC2A500QI	50	4	1590 (62.6)	965 (2,127)	42.8 (94.4)
LCA750TI	75	3	2338 (92.0)	1700 (3,748)	73.5 (162.0)
LCA1000QI	100	4	2455 (96.7)	2200 (4,850)	98.0 (216.1)

Performance						
Model	Lifting Capacity Metric Tons	Hoist Performance				Working Air Pressure bar (psi)
		Lifting Speed		Lowering speed m/min (fpm)	Required Air Flow m <sup>3</sup> /min (cfm)	
		Full Load m/min (fpm)	No Load m/min (fpm)			
LC2A015SI	1.5	6.2 (20.3)	11 (36.1)	8.5 (27.9)	4 (141)	6.3 (90)
LC2A030DI	3	3 (9.8)	5.5 (18)	4 (13.1)	4 (141)	6.3 (90)
LC2A040SI	4	3.9 (12.8)	7 (23)	4.5 (14.8)	4.5 (159)	6.3 (90)
LC2A060QI	6	1.5 (4.9)	2.5 (8.2)	2 (6.6)	4 (141)	6.3 (90)
LC2A060SI	6	2.2 (7.2)	3.6 (11.8)	2.7 (8.9)	5.2 (184)	6.3 (90)
LC2A080DI	8	1.8 (5.9)	3.5 (11.5)	2.2 (7.2)	4.4 (155)	6.3 (90)
LC2A120DI	12	1.1 (3.6)	1.8 (5.9)	1.3 (4.3)	5 (177)	6.3 (90)
LC2A125SI	12.5	3.2 (10.5)	6 (19.7)	5 (16.4)	10 (353)	6.3 (90)
LC2A180TI	18	0.7 (2.3)	1.2 (3.9)	0.9 (3)	5 (177)	6.3 (90)
LC2A250QI	25	0.5 (1.6)	0.9 (3)	0.6 (2)	5 (177)	6.3 (90)
LC2A250DI	25	1.6 (5.2)	3 (9.8)	2.5 (8.2)	10 (353)	6.3 (90)
LC2A375TI	37.5	1.1 (3.6)	2 (6.6)	2 (6.6)	10 (353)	6.3 (90)
LC2A500QI	50	0.8 (2.6)	1.5 (4.9)	1.5 (4.9)	10 (353)	6.3 (90)
LCA750TI	75	0.4 (1.3)	0.7 (2.3)	0.7 (2.3)	10 (353)	6.3 (90)
LCA1000QI	100	0.3 (1)	0.5 (1.6)	0.5 (1.6)	10 (353)	6.3 (90)



Performance test conducted per European standard EN range 14492-2.  
<sup>(1)</sup> Rack and pinion trolley configuration traverse speed is 50% of speed stated in table above.

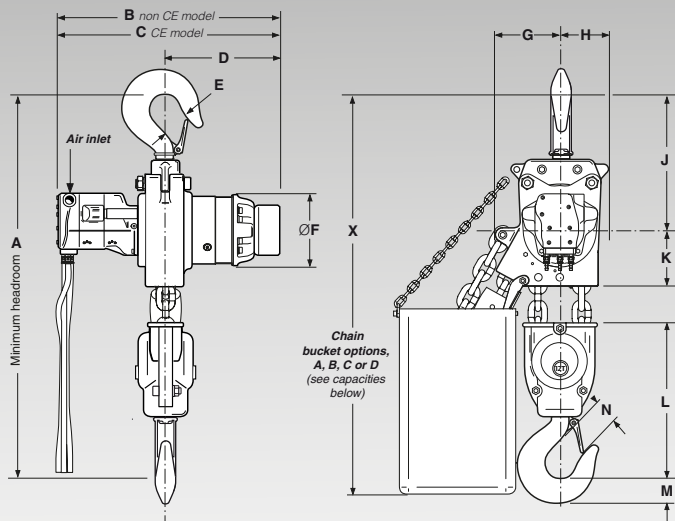

Dimensions shown are mm. Dimensions in Brackets [ ] are inches.  
Dimensions are subject to change. Contact factory for certified drawings.

Model	A	B	C	D	E	F	G	H	J	K	L	M	N	Air Inlet Ø
LC2A015SI	409	385	410	210	27	137	112	68	173	90	146	30	27	3/4" BSP
LC2A030DI	549	385	410	210	35	137	112	68	202	90	257	37	35	3/4" BSP
LC2A040SI	580	580	606	297	35	192	183	71	264	127	190	37	35	1" BSP
LC2A060QI	653	448	474	236	43	137	112	68	266	90	296	50	43	3/4" BSP
LC2A060SI	717	605	630	310	43	192	233	75	350	139	228	50	43	1" BSP
LC2A080DI	807	580	606	297	53	192	140	115	307	127	373	60	53	1" BSP
LC2A120DI	945	605	630	310	58	192	175	133	370	152	424	67	58	1" BSP
LC2A125SI	865	725	816	265	58	—	276	194	368	226	296	67	58	1 1/4" BSP <sup>(1)</sup>
LC2A180TI	1063	724	750	386	78	192	195	98	427	152	484	80	78	1" BSP
LC2A250QI	1156	724	750	367	87	192	175	118	474	152	530	96	87	1" BSP
LC2A250DI	1235	460	265	94	87	91	276	194	80	459	205	276	572	1 1/4" BSP
LC2A375TI	1484	514	373	132	103	91	229	194	125	565	205	298	714	1 1/4" BSP
LC2A500QI	1590	541	346	150	118	91	229	194	140	622	205	352	763	1 1/4" BSP
LCA750TI	2338	557	718	190	160	75	566	304	180	973	310	420	1055	1 1/4" BSP
LCA1000QI	2455	594	682	250	184	75	566	304	200	1030	314	490	1111	1 1/4" BSP

### Chain Bucket Capacity And Height – A, B, C or D Options

Model	Chain Bucket, Type A			Chain Bucket, Type B			Chain Bucket, Type C			Chain Bucket, Type D		
	Bucket Material	Corresponding Height of Lift Capacity	Height "X"	Bucket Material	Corresponding Height of Lift Capacity	Height "X"	Bucket Material	Corresponding Height of Lift Capacity	Height "X"	Bucket Material	Corresponding Height of Lift Capacity	Height "X"
		(m)	(mm)		(m)	(mm)		(m)	(mm)		(m)	(mm)
LC2A015SI	Canvas	12	628	Canvas	30	728	Canvas	60	828	Metal	80	TBA
LC2A030DI	Canvas	6	657	Canvas	15	757	Canvas	30	857	Metal	40	TBA
LC2A040SI	Canvas	12	847	Canvas	25	947	Metal	40	1107	Metal	60	1147
LC2A060QI	Canvas	3	721	Canvas	7.5	821	Canvas	15	921	Metal	20	TBA
LC2A060SI	Canvas	12	1065	Metal	26	1265	Metal	40	1265	Metal	60	1445
LC2A080DI	Canvas	6	890	Canvas	12.5	990	Metal	20	1150	Metal	30	1190
LC2A120DI	Canvas	6	1085	Metal	13	1285	Metal	20	1285	Metal	30	1465
LC2A125SI	Metal	30	475	Metal	60	800	—	—	—	—	—	—
LC2A180TI	Canvas	4	1142	Metal	8.5	1342	Metal	13	1342	Metal	20	1522
LC2A250QI	Canvas	3	1189	Metal	6.5	1389	Metal	10	1389	Metal	15	1569
LC2A250DI	Metal	15	840	Metal	30	1055	—	—	—	—	—	—
LC2A375TI	Metal	10	840	Metal	20	1055	—	—	—	—	—	—
LC2A500QI	Metal	7.5	840	Metal	15	1055	—	—	—	—	—	—
LCA750TI	Metal	10	2462	Metal	20	3052	—	—	—	—	—	—
LCA1000QI	Metal	7.5	2462	Metal	15	3052	—	—	—	—	—	—

(1) 1 1/2" air inlet with CE package.

## How to Order

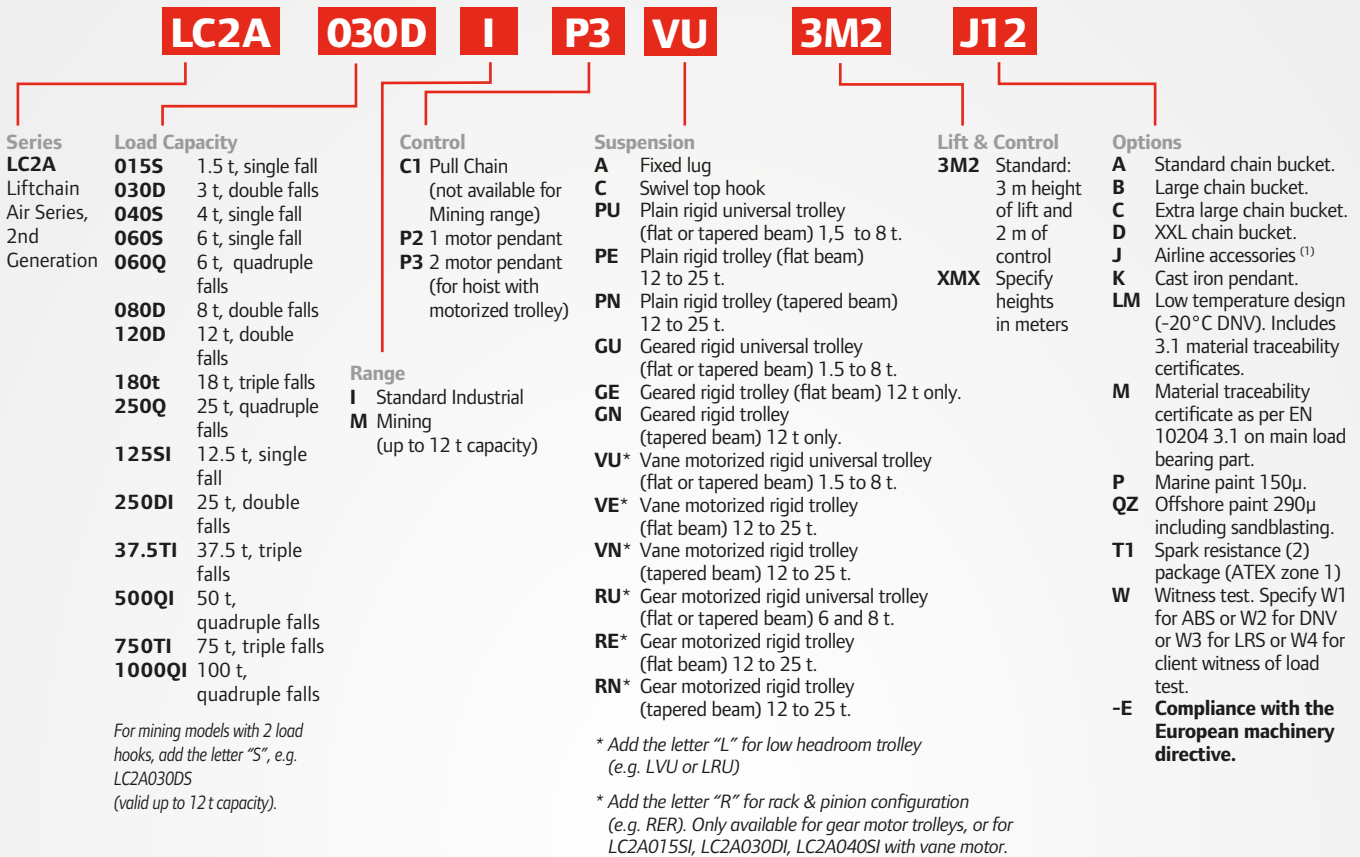

<sup>(1)</sup> For protection during shipment and due to the wide range of installation variables, the airline accessories are shipped loose for client installation. Specify J1: Filter, J2: Lubricator, J3: Regulator or numerical combination.

<sup>(2)</sup> Option T1 includes the following:  
For the hoist: Cast iron pendant and bronze coated bottom hook assembly  
For the trolley: Solid bronze wheels (all trolleys).  
In addition for motorized trolleys, pinion drive in solid bronze or stainless steel and cast iron pendant.  
In addition for geared trolleys, bronze coated hand wheel with brass hand chain guide.



For More Information [www.ingersollrandproducts.com/lifting](http://www.ingersollrandproducts.com/lifting) [lifting@irco.com](mailto:lifting@irco.com)

Ingersoll Rand, IR, the IR logo and Impactool are trademarks of Ingersoll Rand, its subsidiaries and/or affiliates. All other trademarks are the property of their respective owners. Nothing contained on these pages is intended to extend any warranty or representation, expressed or implied, regarding the product described herein. Any such warranties or other terms and conditions of sale of products shall be in accordance with Ingersoll Rand's standard terms and conditions of sale for such products, which are available upon request. Product improvement is a continuing goal at Ingersoll Rand. Designs and specifications are subject to change without notice or obligation. Unless otherwise noted this equipment is not designed for transporting people or lifting loads over people. It is the user's responsibility to determine the suitability of this product for any particular use and to check compliance with applicable regulations. Before installation, see maintenance and operations manual for additional warnings and precautions.