

MP PUMPS HTW SERIES**TEMPUFLO**INSTRUCTION BULLETIN
HTW120

Read this bulletin in full before installing, operating or servicing this pump. If any of the warnings of this bulletin are ignored serious injury or death could occur.

**WARNING!**

If any of the items listed below are violated, serious injury or death from burns caused by hot water may occur.

Do not perform service or maintenance when pumping system is pressurized or hot.

Do not operate the pump in a manner that it was not intended to be used.

Do not install for use in an open environment where people are present.

Do not install in a rigid piping system that does not allow the pipe to expand and cause the pump to be strained.

Do not allow severe temperature changes to occur in a short time period within the pumping system.

Do not operate beyond the pressure or temperature limits stated in the product literature, see pressure temperature curve.

Do not mount pump in conditions that high piping loads exist on the pump flanges.

Do not continue to operate the pump when unusual noise or vibration occurs.

Do not continue to operate the pumping system when a known leak exists or the system starts to smoke.

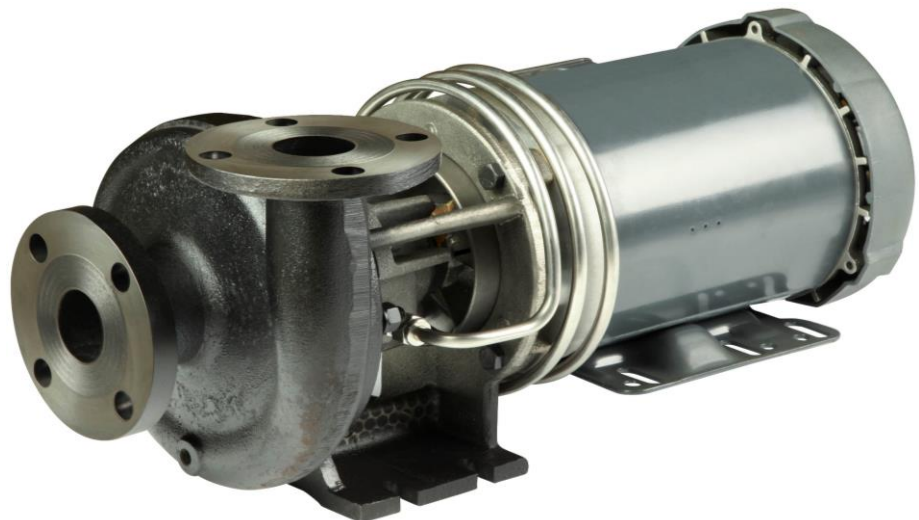

34800 BENNETT • FRASER, MI 48026-1686
(586) 293-8240 • FAX (586) 293-8469
(800) 563-8006 • www.mppumps.com

FORM 3080-A (5/15)

PRINTED IN THE U.S.A.

MP PUMPS HTW SERIES

APPLICATION AND INSTALLATION INSTRUCTIONS

It is important that this Instruction Bulletin be read carefully to fully familiarize yourself with the pump assembly arrangement. The instructions contained herein pertain to installation and maintenance of the pump assembly only. Check unit carefully to make certain that no parts are missing or have been broken in shipment.

Any questions call 800-563-8006 or visit mppumps.com

INSTALLATION

1. The pump must be installed in a horizontal shaft position.
2. The housing may be rotated to a horizontal or vertical discharge to fit the particular piping installation.
3. Rigid and supported piping must be used that will not strain the pump housing when temperature changes are made during the use of the pump.
4. The piping system must be free of foreign material before start up.
5. Pipe thread sealing compound must be used on the NPT flanges that is compatible with the fluid being pumped and is rated for the temperature requirements.
6. The installation should permit adequate circulation of air to provide proper cooling of the motor and pump seal.
7. Do not install in a sealed enclosure or insulate the pump adapter and motor. The motor and/or pump seal may fail from excessive heat.
8. A good installation will have an enclosure that provides adequate air flow of ambient air to the motor of the pump.

OPERATION AND MAINTENANCE

Any system leak should be repaired immediately.

Ideal mechanical seal life is 20,000 hours. Reduced seal life may be experienced from extreme conditions.

Once disassembled check the impeller and other wear items for unusual wear. Replace if necessary.

START-UP

1. Fill pumping system with fluid before start-up.
2. Check for leaks before insulating the piping system.
3. Check for proper shaft rotation by jogging the power and observing the fan clamp. Rotation arrows are provided on the pump housing.
4. The seal cavity inside the pump will internally vent during fill and start-up.
5. A small amount of fluid may leak from the seal cavity at the shaft; this is normal for a new installation and will stop after approximately one hour.
6. Do not allow the pump to run dry, or continue to operate the pump when it is noisy, vibrating, or leaks are observed. These noticeable signs give a warning that something is wrong with the equipment and must be investigated to avoid possible damage or injury from burns caused by hot fluids.

When servicing the pump, care should be taken that the pump has cooled to a sufficient temperature to permit disassembly. Operating personnel should be warned to exercise care and utilize eye and skin protection when servicing the pump.



34800 BENNETT • FRASER, MI 48026-1686
(586) 293-8240 • FAX (586) 293-8469
(800) 563-8006 • www.mppumps.com

FORM 3080-A (5/15)

PRINTED IN THE U.S.A.

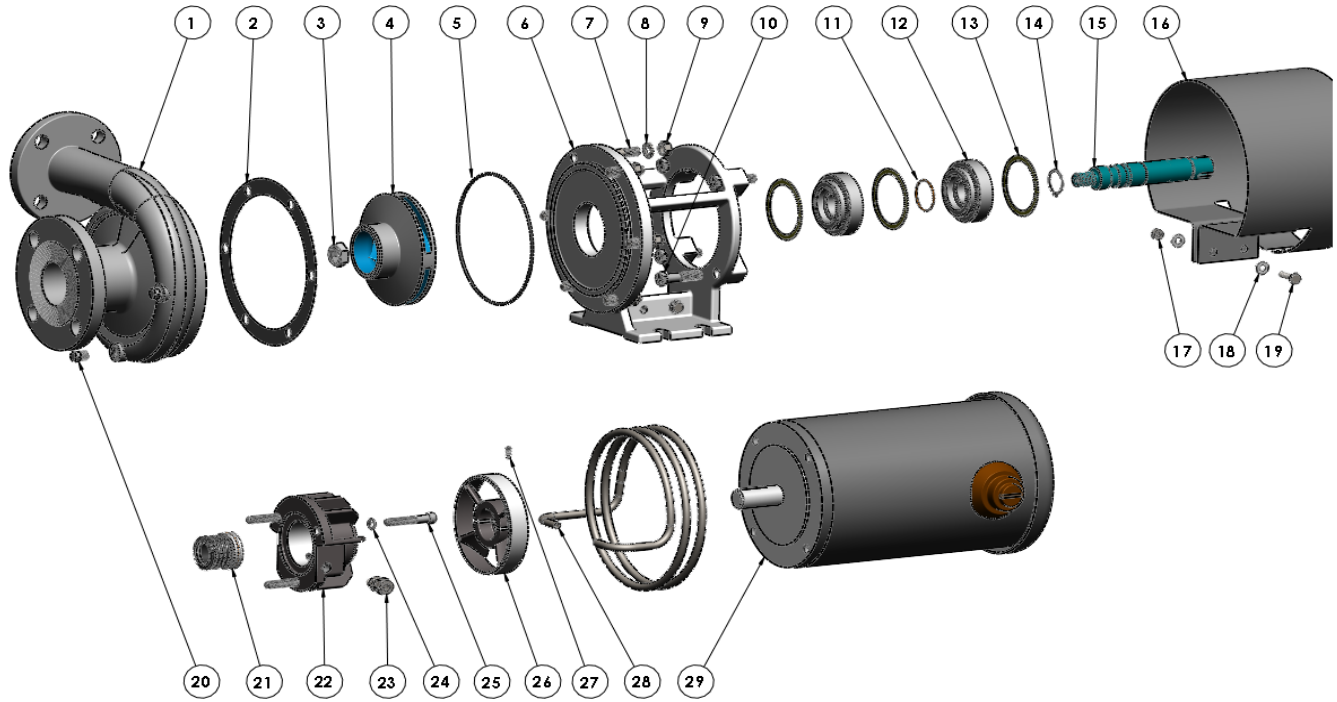

ITEM NO.	PART NUMBER	DESCRIPTI ON	MATERIAL	QTY.
1	31492	HOUSING	DUCTILE IRON	1
2	35558	GASKET	KLINGERSIL	1
3	22655	HEX JAM NUT 5/8-18	304 STAINLESS STEEL	1
4	30223	IMPELLER	CAST IRON	1
5	29715	O RING AS 568-162	VITON	1
6	36624	ADAPTOR	DUCTILE IRON	1
7	21261	STUD 3/8-16X1.63	304 STAINLESS STEEL	6
8	21266	LOCKWASHER 3/8 X 1/8	304 STAINLESS STEEL	6
9	21268	HEXNUT 3/8-16	304 STAINLESS STEEL	6
10	41259	CAPSCREW 3/8-16X1.75	STEEL	4
11	29230	O-RING 1.301ID X .070	VITON	1
12	29158	ISOLATOR	CG	2
13	35559	GASKET	KLINGERSIL	3
14	29782	SNAP RING	STEEL	1
15	29781	DRIVE SLEEVE	STAINLESS STEEL	1
16	36640	SHEILD	STEEL	1
17	21241	HEXNUT 1/4-20	304 STAINLESS STEEL	2
18	27261	WASHER	STEEL	4
19	33563	CAPSCREW 1/4-20X1	304 STAINLESS STEEL	2
20	21585	PIPE PLUG 1/8 NPT	ZPS	2
21	29773	SEAL ASSEMBLY	CAR/SIC	1
22	36628	HOUSING SEAL	DUCTILE IRON	1
23	36645	ADP FITTING	304 STAINLESS STEEL	2
24	29765	WASHER FLAT .50X.327X.093	STEEL	3
25	29178	CAPSCREW 5/16-18X2.0	STEEL	3
26	29775	CLAMP FAN ASSEMBLY	DUCTILE IRON/STEEL	1
27	33417	SET SCREW 1/4-28X1/2	STEEL	1
28	36641	HE COIL	304 STAINLESS STEEL	1
29	25920	ELECTRIC MOTOR	TEFC	1

MP PUMPS HTW SERIES

ASSEMBLY INSTRUCTIONS

1. Assemble drive sleeve # 15, impeller # 4 and nut # 3. The drive sleeve needs to be held stationary when shouldering the impeller and nut.
2. Thread pipe plug # 20 into housing # 1. Torque 1/8" NPT side of # 23 ferrule fitting with 27-30ft-lbs into seal housing # 22. Install O-ring # 5 into adapter # 6.
3. With the housing # 1 on the bench, suction down, place the impeller and drive sleeve assembly #'s 16,3 & 2 into the housing.
4. Assemble the adapter # 6 to the housing with gasket # 4 between them. Use (6) 3/8-16 studs # 7, washers # 8 and hexnuts # 9. Torque to 27-30 ft. lbs.
5. Install (3) gaskets # 13, (2) carbon isolators # 12 and (1) O-ring # 11 onto drive sleeve. The O-ring and (1) gasket go between the two carbon isolators. The second gasket goes between the carbon isolators and the adapter. The third gasket goes between the carbon isolator and the seal housing # 22. Install snap ring #14 (29782) onto the drive sleeve groove.
6. Assemble seal # 21 onto the drive sleeve with a liberal amount of MS-180 LUBRICANT to prevent the seal from being damaged.
7. Press the stationary seal seat # 21 into the seal housing # 22. Position and press in the seal seat with the polished side up.
8. Assemble the seal housing # 22 to the adapter # 6 with (3) 5/16-18 screws # 25. Securing the seal housing in place, thread the (3) 5/16-18 screws in and torque them to 25 inch-lbs. each. Working around the bolt circle, tighten the screws in 25 inch-lbs. increments until each screw is tightened to 150 inch-lbs.
9. Assemble fan clamp # 26 and set screw # 27 to drive sleeve with the set screw inside the slot on the drive sleeve.
10. Place ferrule fitting side of # 23 onto both sides of heat exchanger coil # 28. Place heat exchanger and ferrule into both sides of the seal housing. Make sure that the coil shoulders up against the 1/8" NPT side of the ferrule fitting. Make the ferrule finger tight. Mark the ferrule nut in the 9 o'clock position, then rotate the ferrule 1- ¼ turns so that the mark is in the 12 o'clock position.
11. Assemble the pump to the motor by sliding the pump onto the motor. Install and tighten the (4) mounting screws. Push the impeller towards the motor until it stops (contact with the impeller and isolator). Tighten the drive clamp screw to 70/90 inch-lbs. followed by the set screw at 70/90 inch-lbs. Rotate the fan clamp and check for excessive rotational drag.



34800 BENNETT • FRASER, MI 48026-1686
(586) 293-8240 • FAX (586) 293-8469
(800) 563-8006 • www.mppumps.com

FORM 3080-A (5/15)

PRINTED IN THE U.S.A.

