



HHLF

1-1/2" or 2" x 1-1/2" or 2" High Head Low Flow Self Priming Centrifugal Pump

HHLF (High Head Low Flow) "HR" high pressure self-priming centrifugal pumps meet USCG specifications for auxiliary fire control (46 CFR compliant) and is ABS type approved.

The high suction centerline and impeller design eliminates premature priming loss while ensuring consistent priming capability. The HHLF pump is capable of achieving up to 25 feet suction lift.

The HHLF series is available close coupled to NEMA "C" Face electric motors or as PumPAKs®. The engine drive models are capable of close coupling to both gasoline and diesel engines with 1" keyed drive shafts. Pedestal mounted pumps are also available.

The volute and impeller are removable and easily replaced.

ABS Type Approval for the HHLF, HHLF 1.5 & HHLF HO - [Download PDF](#)

SPECIFICATIONS:

Suction And Discharge	1-1/2" x 1-1/2" NPT, 2" x 2" NPT
Materials Of Construction	Bronze, Cast iron
Flow	Up to 140 GPM
Head Feet	Up to 190'
Impeller	6.7" cast iron Class 30 or silicon bronze CA 875
Drive Options	Close coupled 184TC, Engine mount 5.5 HP, Engine mount 7.5 HP, Hydraulic motor .73 cu. in., Pedestal, PumPAK® (without motor)
Seal	Optional seals available, Standard carbon / ceramic / Viton
Adaptor	Cast Iron Class 30 or Silicon Bronze CA 875
46 Cfr Compliant	Yes
Abs Type Approved	Yes



Application

- Agricultural
- Commercial
- Industrial
- Marine
- OEM

Drive Sleeve

- 304 Stainless Steel

Features

- 46 CFR Compliant
- ABS Type Approved

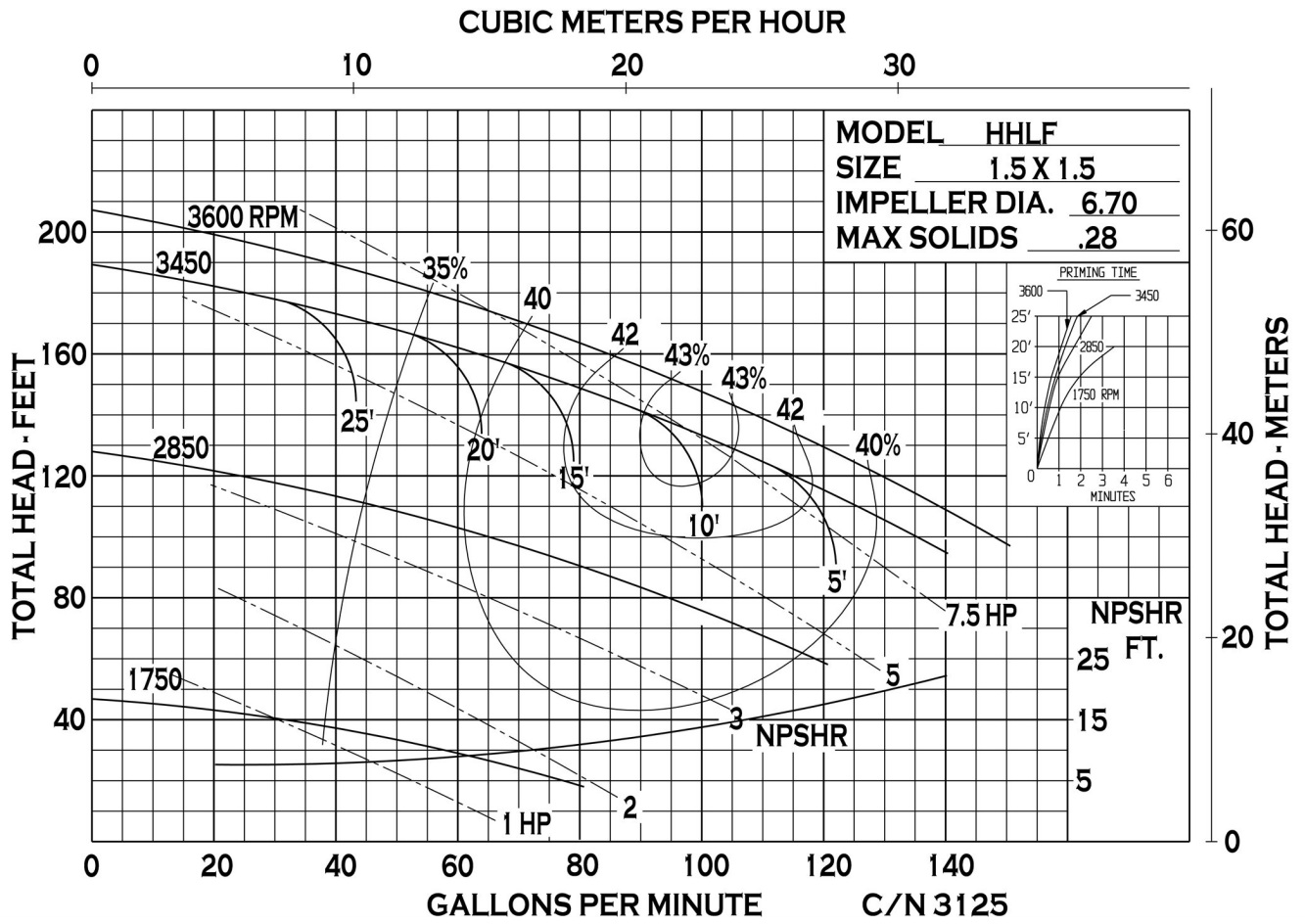

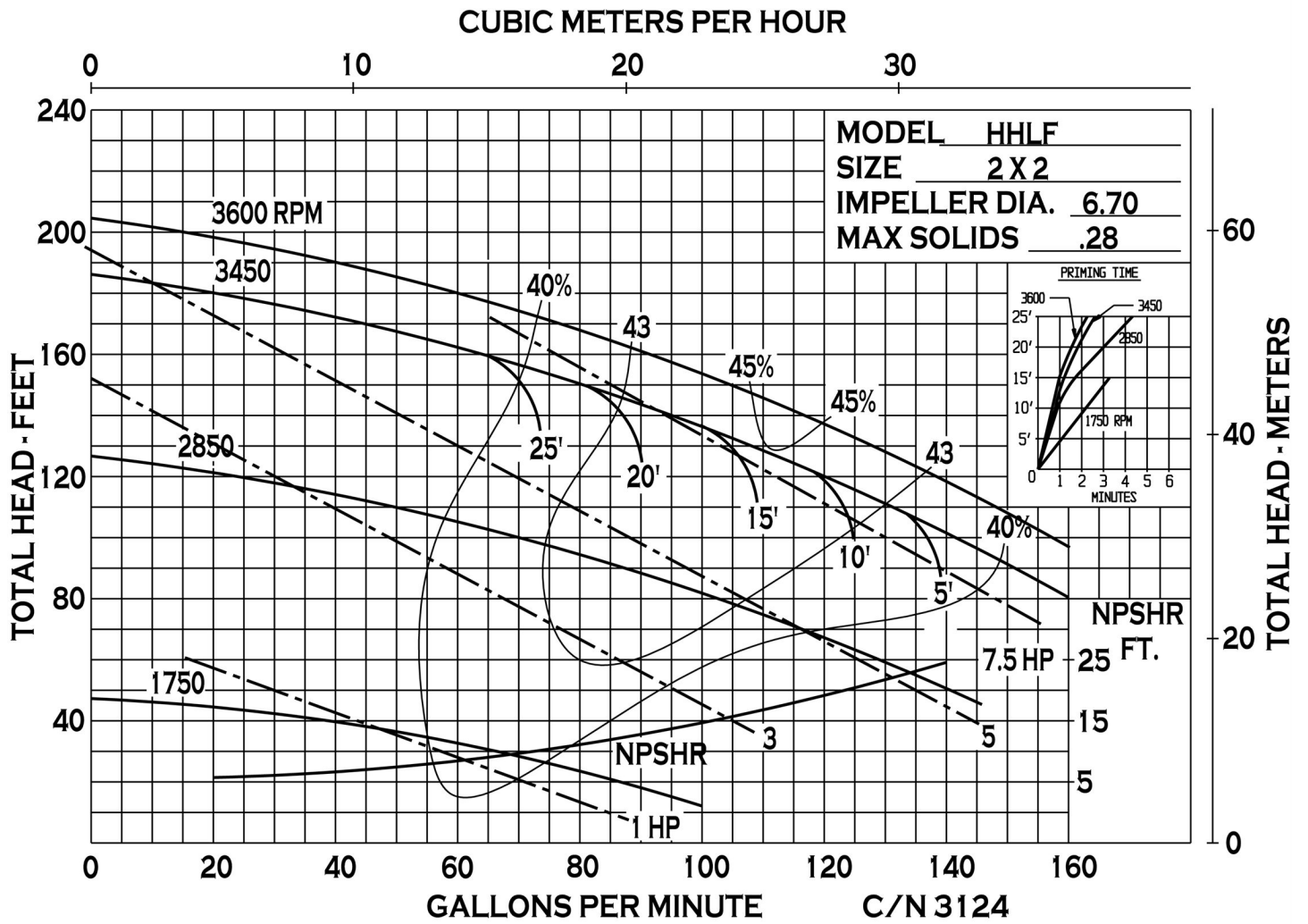

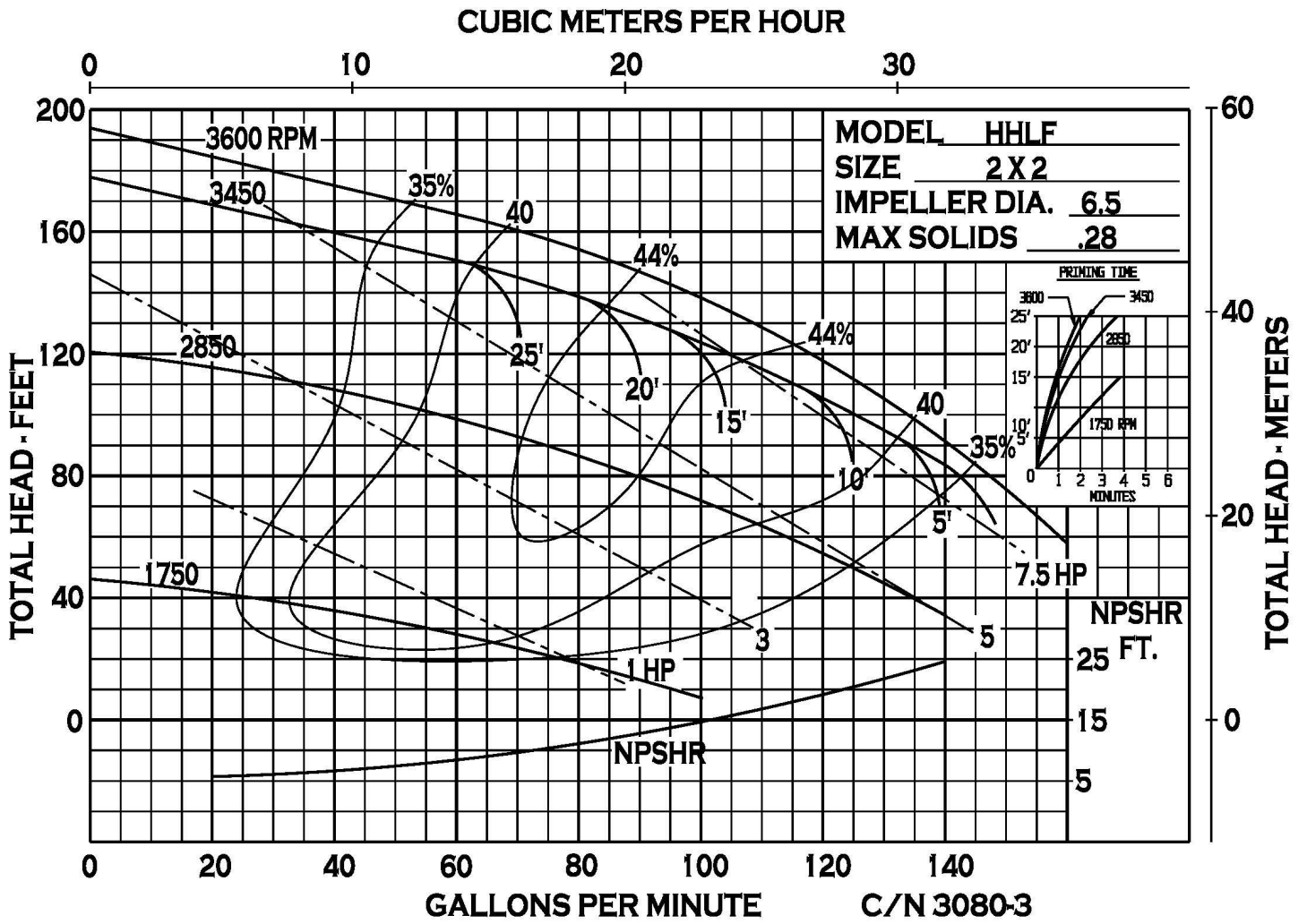

HHLF 1.5" (2.0") CLOSE COUPLED ELECTRIC MOTOR

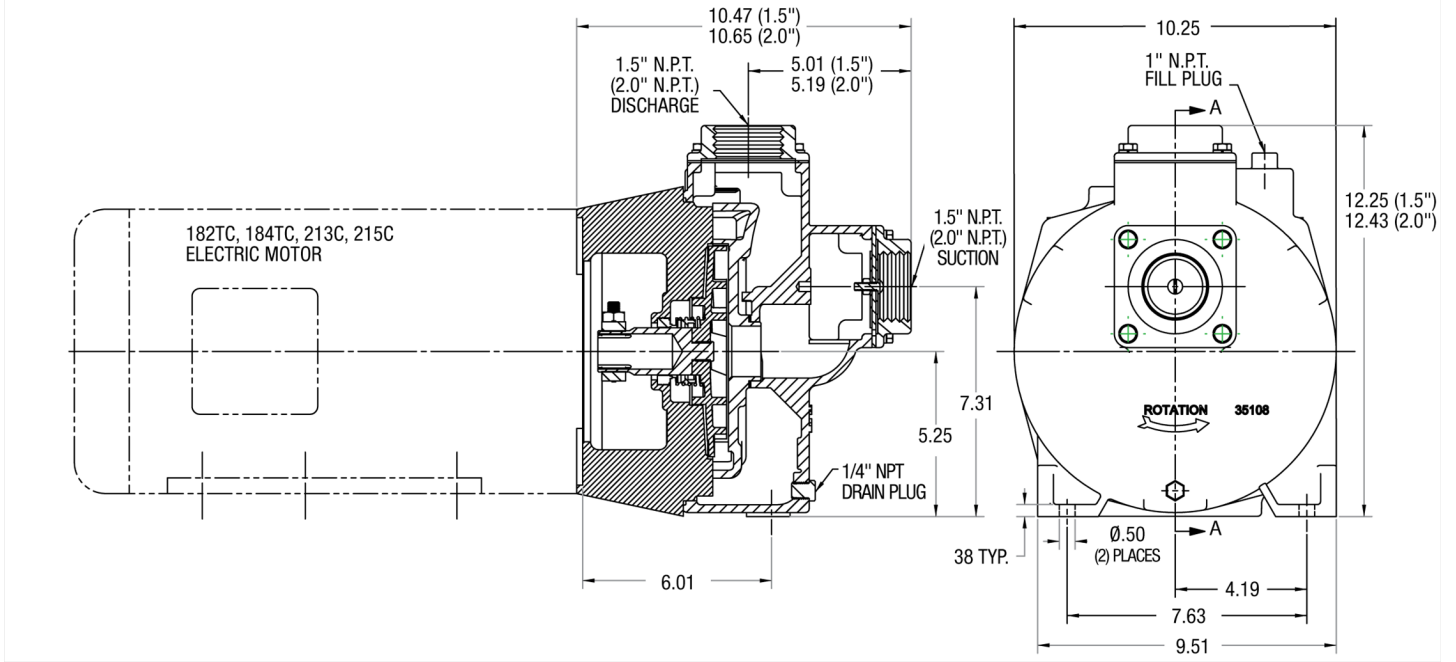

HHLF 1.5" (2.0") CLOSE COUPLED MTR PUMPAK

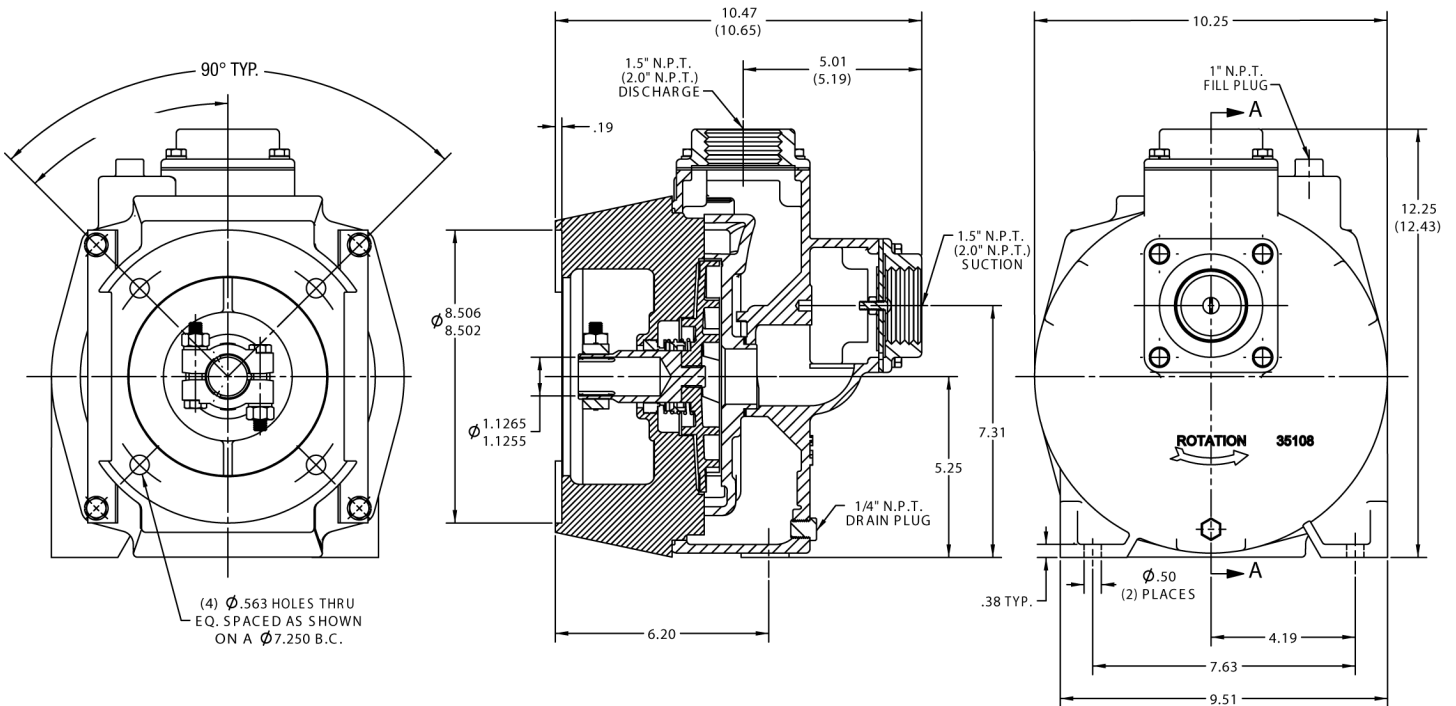

HHLF 1.5" (2.0") ENGINE MOUNT PUMPAK

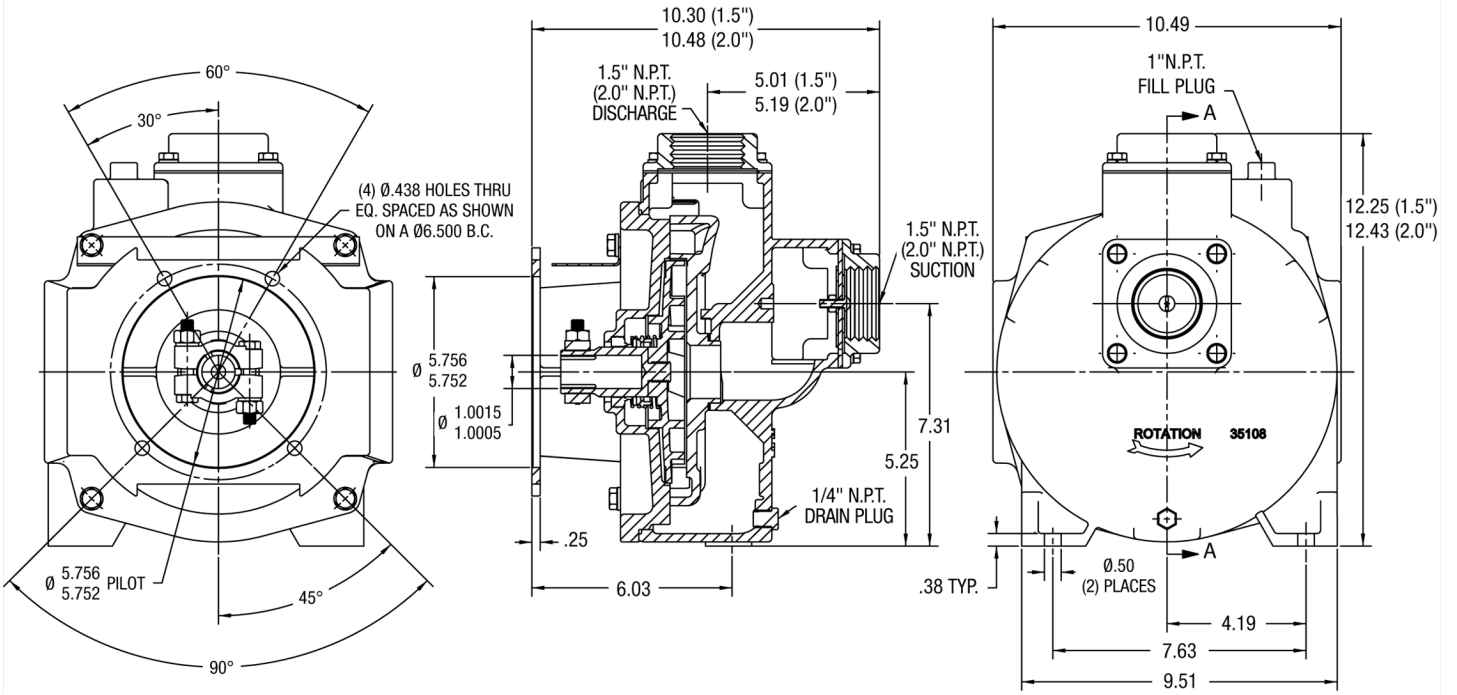

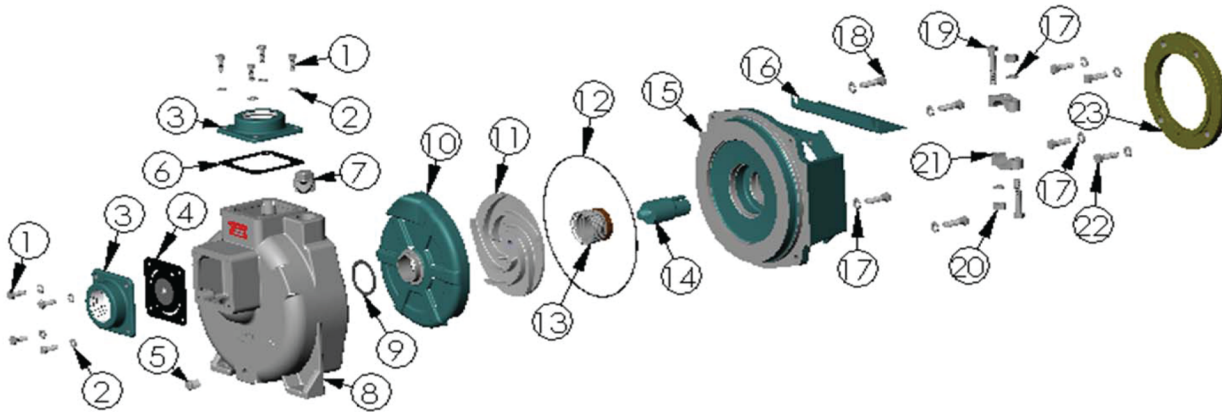

PART NO.	ITEM NO.	DESCRIPTION	QTY.		PART NO.	ITEM NO.	DESCRIPTION	QTY.
21242	1	CAPSCREW - 5/16"-18 X 7/8" - S.S.	8	*	28907	12	O-RING - AS-568-175 - VITON	1
21238	2	LOCKWASHER - 5/16" - S.S.	8	*	29533	13	SEAL - Ø1.5 - T-21	1
22311	3	SCT. & DISCRG FLG. 2" N.P.T. - CAST	2		28825	14	DRIVE SLEEVE -Ø1.00 - S.S.	1
* 23022	4	FLAPPER ASSEMBLY	1		29092	15	ADAPTER - CAST	1
41475	5	PIPE PLUG - 1/4" N.P.T. - CAST	1		29192	16	CLAMP GUARD - STEEL	1
* 22256	6	GASKET - BUNA	1		21266	17	LOCKWASHER - 3/8" - S.S.	10
41483	7	PIPE PLUG - 1" N.P.T. - CAST	1		21259	18	CAPSCREW - 3/8"-16 X 1.38 - S.S.	4
35109	8	HOUSING - CAST	1		21269	19	CAPSCREW - 3/8"-16 X 2.25 - S.S.	2
* 28908	9	GASKET - VITON	1		21268	20	HEXNUT - 3/8"-16 - S.S.	2
31988	10	VOLUTE - CAST	1		22356	21	CLAMP Ø1.00 - S.S.	2
35919	11	IMPELLER - Ø6.70 - CAST	1		21274	22	CAPSCREW - 3/8"-16 X 1.25 - S.S.	4
					29339	23	ENGINE ADAPTER - CAST	1

* SUGGESTED REPLACEMENT PARTS

MP PUMPS SERVICE PARTS LIST

HHLF "HR" - Cast Iron 1.5" x 1.5" 2.0" x 2.0"	Self Priming Electric Motor
--	--

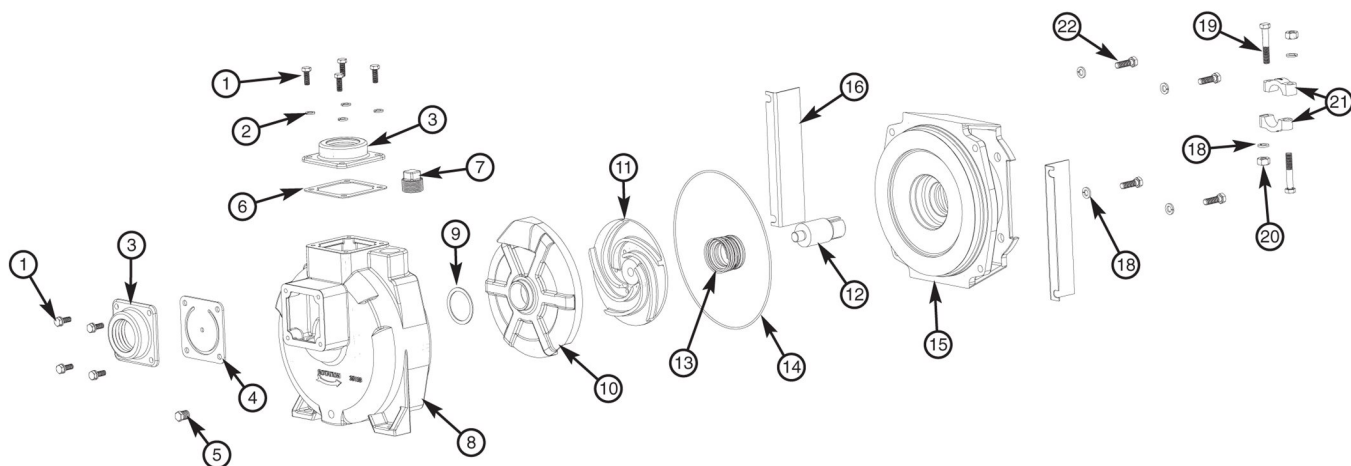

PART NO.	ITEM NO.	DESCRIPTION	QTY.	PART NO.	ITEM NO.	DESCRIPTION	QTY.
21242	1	CAPSCREW - 5/16"-18 X 7/8" - S.S.	8	28826	12	DRIVE SLEEVE 1.12" S.S.	1
21238	2	LOCKWASHER - 5/16" - S.S.	8	29533 *	13	SEAL - Ø1.5 - T-21	1
22266	3	1.5" SCT & DISCH FLANGE	2	28907 *	14	O-RING - VITON	1
22311	3	2" SCT & DISCH FLANGE	2	28824	15	ADAPTER - CAST IRON	1
23022 *	4	FLAPPER ASSEMBLY - BUNA	1	29192	16	CLAMP GUARD - STEEL	2
41475	5	PIPE PLUG - 1/4" N.P.T	1	21266	17	LOCKWASHER - 3/8" X 1/8" - S.S.	4
22256 *	6	GASKET - BUNA	1	23039	ASSY	CLAMP	1
41483	7	PIPE PLUG - 1" N.P.T. - CAST IRON	1	INCL	18	LOCKWASHER - 3/8" X 1/8" - S.S.	2
35109	8	HOUSING - CAST IRON "HR"	1	INCL	19	CAPSCREW - 3/8" - 16 X 2.25" S.S.	2
28908 *	9	GASKET - VITON	1	INCL	20	HEXNUT - 3/8" - 16 - S.S.	2
31988	10	VOLUTE - CAST IRON	1	INCL	21	CLAMP 1.0 - S.S	2
35919	11	IMPELLER - CAST IRON 6.7 IMP DIA.	1	21274	22	CAPSCREW - 3/8" - 16 X 1.25" S.S.	4
36084	11	IMPELLER - CAST IRON 6.5 IMP DIA.	1				

*-RECOMMENDED REPLACEMENT PARTS

MP PUMPS SERVICE PARTS LIST

HHLF "HR" - Cast Iron
1.5" x 1.5"
2.0" x 2.0"

Self Priming
Engine mount
Pedestal Mount

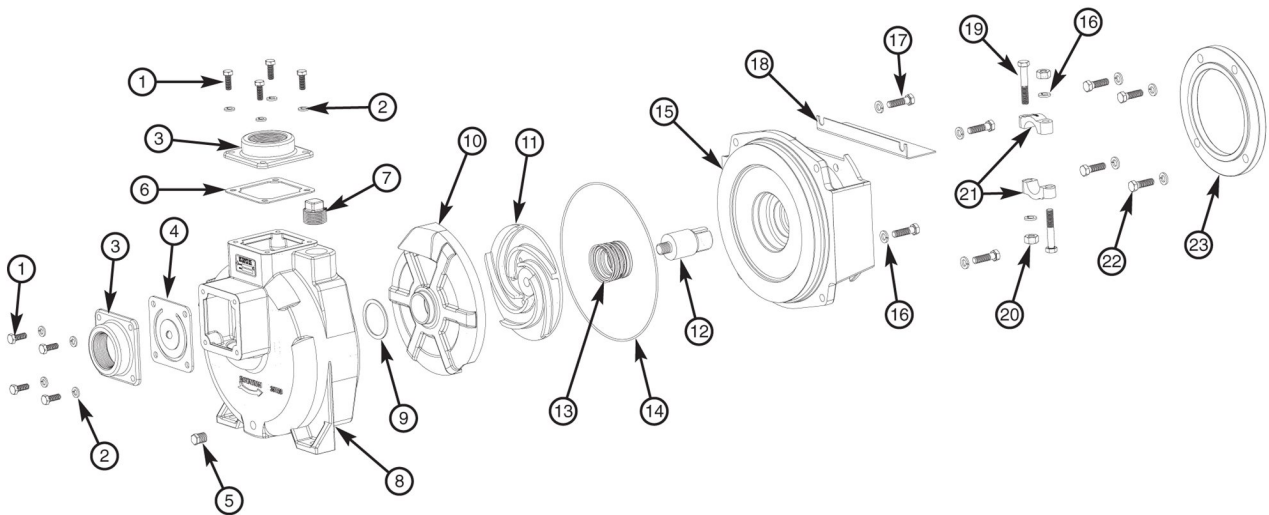

PART NO.	ITEM NO.	DESCRIPTION	QTY.	PART NO.	ITEM NO.	DESCRIPTION	QTY.
21242	1	CAPSCREW - 5/16"-18 X 7/8" - S.S.	8	29533 *	13	SEAL - Ø1.5 - T-21	1
21238	2	LOCKWASHER - 5/16" - S.S.	8	28907 *	14	O-RING - VITON	1
22266	3	1.5" SCT & DISCH FLANGE	2	29092	15	ADAPTER - CAST IRON PEM	1
22311	3	2" SCT & DISCH FLANGE	2	21266	16	LOCKWASHER - 3/8" X 1/8" S.S.	8
23022 *	4	FLAPPER ASSEMBLY - BUNA	1	21259	17	CAPSCREW - 3/8"-16 X 1-3/8" S.S.	4
41475	5	PIPE PLUG - 1/4" N.P.T	1	29192	18	CLAMP GUARD - STEEL	1
22256 *	6	GASKET - BUNA	1	23039	ASSY	CLAMP	1
41483	7	PIPE PLUG - 1" N.P.T. - CAST IRON	1	INCL	19	CAPSCREW - 3/8" - 16 X 2.25" - S.S.	2
35109	8	HOUSING - CAST IRON "HR"	1	INCL	20	HEXNUT - 3/8" - 16 - S.S.	2
28908 *	9	GASKET - VITON	1	INCL	21	CLAMP 1.0 - S.S.	2
31988	10	VOLUTE - CAST IRON	1	INCL	16	LOCKWASHER - 3/8" X 1/8" S.S.	2
35919	11	IMPELLER - CAST IRON 6.7 IMP DIA.	1	21274	22	CAPSCREW - 3/8"-16 X 1.25" S.S.	4
36084	11	IMPELLER - CAST IRON 6.5 IMP DIA.	1	29339	23	ADAPTER PLATE FOR 5.75 PILOT	1
28825	12	DRIVE SLEEVE 1.0" S.S.	1	26163	N/S	PEDESTAL ASSY (PED MOUNT ONLY)	1

N/S = Not Shown

*-RECOMMENDED REPLACEMENT PARTS

MP PUMPS SERVICE PARTS LIST

HHLF "HR" - Bronze 1.5" x 1.5" 2.0" x 2.0"	Self Priming Electric Motor
---	--

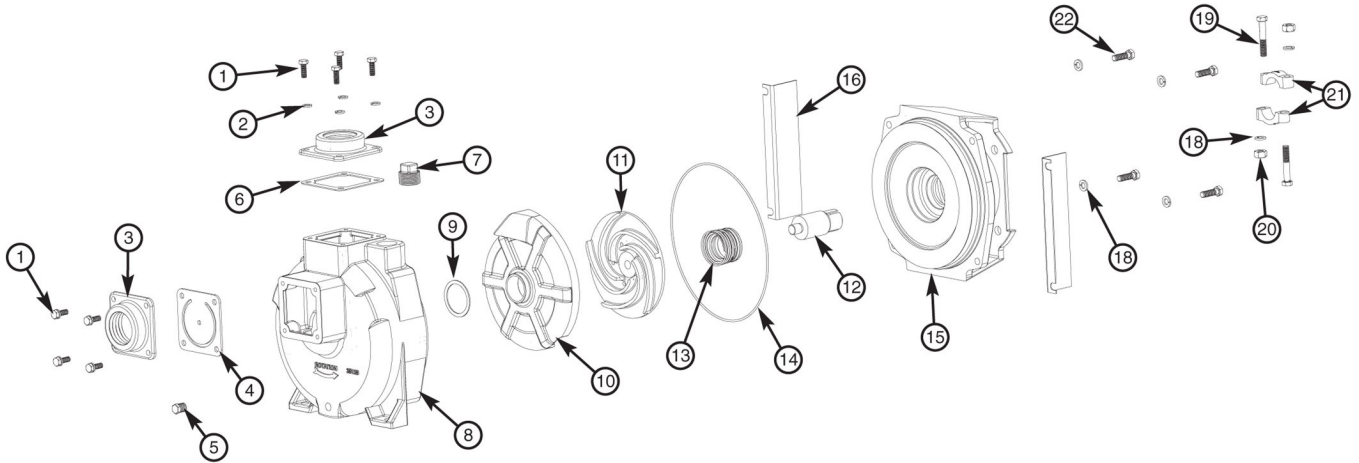

PART NO.	ITEM NO.	DESCRIPTION	QTY.	PART NO.	ITEM NO.	DESCRIPTION	QTY.
21242	1	CAPSCREW - 5/16"-18 X 7/8" - S.S.	8	28826	12	DRIVE SLEEVE 1.12" S.S.	1
21238	2	LOCKWASHER - 5/16" - S.S.	8	29533 *	13	SEAL - Ø1.5 - T-21	1
22265	3	1.5" SCT & DISCH FLANGE	2	28907 *	14	O-RING - VITON	1
22310	3	2" SCT & DISCH FLANGE	2	29057	15	ADAPTER - BRONZE	1
23022 *	4	FLAPPER ASSEMBLY - BUNA	1	29192	16	CLAMP GUARD - STEEL	2
21186	5	PIPE PLUG - 1/4" N.P.T	1	21266	17	LOCKWASHER - 3/8" X 1/8" - S.S.	4
22256 *	6	GASKET - BUNA	1	23039	ASSY	CLAMP	1
22378	7	PIPE PLUG - 1" N.P.T. - BRONZE	1	INCL	18	LOCKWASHER - 3/8" X 1/8" - S.S.	2
35118	8	HOUSING - BRONZE "HR"	1	INCL	19	CAPSCREW - 3/8" - 16 X 2.25" S.S.	2
28908 *	9	GASKET - VITON	1	INCL	20	HEXNUT - 3/8" - 16 - S.S.	2
33453	10	VOLUTE - BRONZE	1	INCL	21	CLAMP 1.0 - S.S.	2
35921	11	IMPELLER - BRONZE 6.7 IMP DIA.	1	21274	22	CAPSCREW - 3/8" - 16 X 1.25" S.S.	4
36082	11	IMPELLER - BRONZE 6.5 IMP DIA.	1				

*-RECOMMENDED REPLACEMENT PARTS

MP PUMPS SERVICE PARTS LIST

HHLF "HR" - Bronze 1.5" x 1.5" 2.0" x 2.0"	Self Priming Engine mount Pedestal Mount
---	---

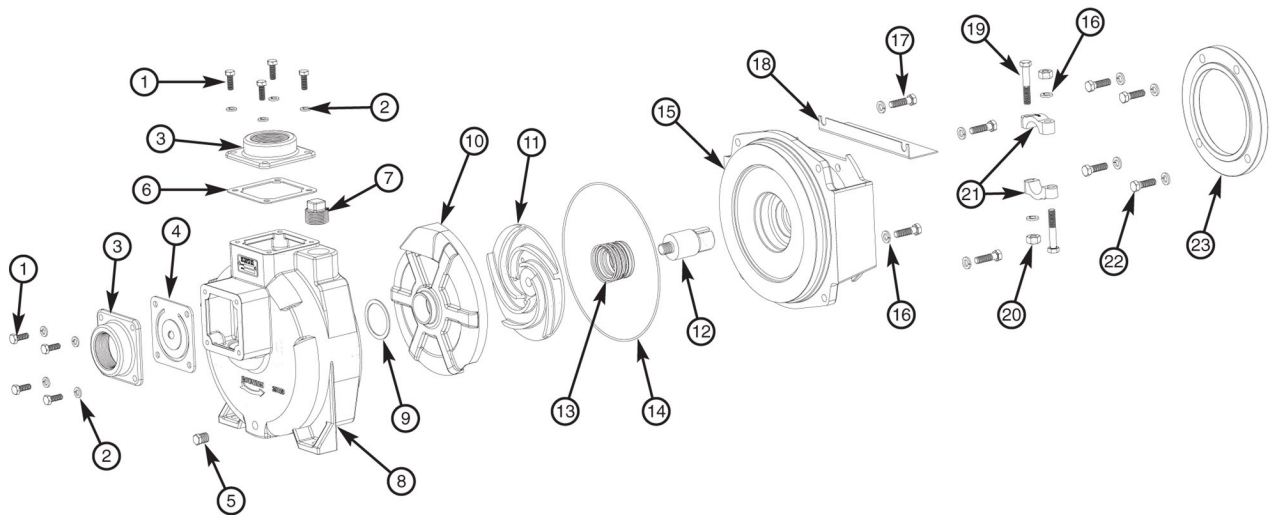

PART NO.	ITEM NO.	DESCRIPTION	QTY.	PART NO.	ITEM NO.	DESCRIPTION	QTY.
21242	1	CAPSCREW - 5/16"-18 X 7/8" - S.S.	8	29533 *	13	SEAL - Ø1.5 - T-21	1
21238	2	LOCKWASHER - 5/16" - S.S.	8	28907 *	14	O-RING - VITON	1
22265	3	1.5" SCT & DISCH FLANGE	2	29093	15	ADAPTER - BRONZE PEM	1
22310	3	2" SCT & DISCH FLANGE	2	21266	16	LOCKWASHER - 3/8" X 1/8" S.S.	10
23022 *	4	FLAPPER ASSEMBLY - BUNA	1	21259	17	CAPSCREW - 3/8"-16 X 1-3/8" S.S.	4
21186	5	PIPE PLUG - 1/4" N.P.T	1	29192	18	CLAMP GUARD - STEEL	1
22256 *	6	GASKET - BUNA	1	23039	ASSY	CLAMP	1
22378	7	PIPE PLUG - 1" N.P.T. - BRONZE	1	INCL	19	CAPSCREW - 3/8" - 16 X 2.25" - S.S.	2
35118	8	HOUSING - BRONZE "HR"	1	INCL	20	HEXNUT - 3/8" - 16 - S.S.	2
28908 *	9	GASKET - VITON	1	INCL	21	CLAMP 1.0 - S.S.	2
33453	10	VOLUTE - BRONZE	1	INCL	16	LOCKWASHER - 3/8" X 1/8" S.S.	2
35921	11	IMPELLER - BRONZE 6.7 IMP DIA.	1	21274	22	CAPSCREW - 3/8"-16 X 1.25" S.S.	4
36082	11	IMPELLER - BRONZE 6.5 IMP DIA.	1	29339	23	ADAPTER PLATE FOR 5.75 PILOT	1
28825	12	DRIVE SLEEVE 1.0" S.S.	1	26163	N/S	PEDESTAL ASSY (PED MOUNT ONLY)	1

N/S = Not Shown

*-RECOMMENDED REPLACEMENT PARTS



34800 BENNETT - FRASER, MI 48026-1686
 (586) 293-8240 - FAX (586) 293-8469
 (800) 563-8006 - www.mppumps.com