

# Metering Ball Valve Type 523



## General

- **Size:** 3/8"–1/2"
- **Material:** PVC, CPVC, PROGEF® Standard PP, SYGEF® Standard PVDF
- **Seat:** PTFE
- **Seals:** EPDM, FPM
- **End Connection:** Solvent cement socket, threaded, flanged, fusion spigot, fusion socket
- **Ball:** V-notch
- **Mounting:** Stainless steel threaded inserts

## Key Certifications

- **FDA CFR 21 177.1520:** PP and PVDF
- **FDA CFR 21 177.2600:** EPDM and FPM
- **FDA CFR 21 177.1550:** PTFE
- **USP 25 Class VI (physiological non-toxic):** PP and PVDF

## Sample Specification

The Type 523 Metering Ball Valve shall be true union and utilize a floating ball design. An integrated index plate shall indicate stroke in degrees. The ball shall be fully molded with a 180° tapered V-notch groove and shall be unidirectional indicated by flow direction arrows on the index plate. The stem shall be blowout proof, utilizing a double o-ring seal and a predetermined break point opposite the media side of the stem seals. The seat carrier shall be adjustable and reverse threaded. The handle shall double as a seat carrier adjustment or removal tool. The valve nut threads shall be of buttress type. Ball seats shall have an elastomeric backing o-ring and all elastomeric seals shall be of like material. ANSI flanged versions shall meet the ANSI B16.5 150lb standard. All valves shall be tested in accordance to ISO9393 and designed to ISO16135 standards. All valves shall be manufactured under ISO9001 for Quality and ISO14001 for Environmental Management. Following assembly, every valve shall be certified bubble tight exceeding Class VI standards.

## Material Specification

PVC valves shall meet ASTM D1784 cell classification 12454 standards. CPVC valves shall meet ASTM D1784 cell classification 23447 standards. PP valves shall meet ASTM D5847-14 cell classification PP0510B66851 standards. PVDF valves shall be type 1, grade 2 according to ASTM D3222 standards. Valves of all materials shall be RoHS compliant.

## Components

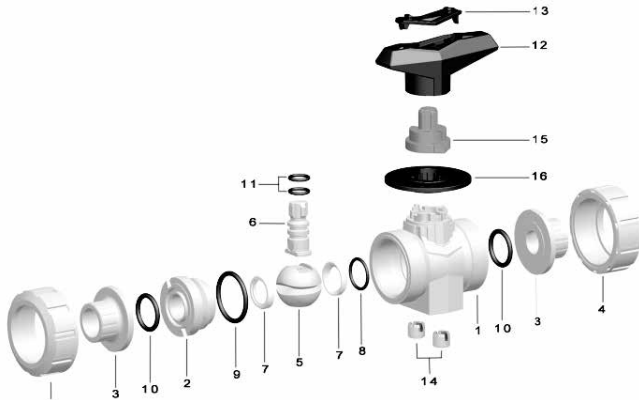

## Optional Features

- **Actuation:** Electric with positioner
- **Material:** ABS
- **Seals:** Alternative materials available upon request
- **Seat:** PVDF
- **End Connection:** Alternatives available upon request
- **Mounting pad:** Additional mounting option for valve base
- **Universal Adapter Kit:** ISO mount for actuation
- **Cleaned:** Silicone free/oil free

### Valve Components

Part	Description	Material
1	Valve body	PVC, CPVC, PP or PVDF
2	Seat carrier	PVC, CPVC, PP or PVDF
3	Valve end	PVC, CPVC, PP, PPn, ABS, PE or PVDF
4	Valve nut	PVC, CPVC, PP or PVDF
5	Ball	PVC, CPVC, PP or PVDF
6	Stem	PVC, CPVC, PP or PVDF
7	Seat	PTFE
8	Backing seal	EPDM or FPM
9	Body seal	EPDM or FPM
10	Face seal	EPDM or FPM
11	Stem seal	EPDM or FPM
12	Handle	Glass-filled PP
13	Handle clip	Glass-filled PP
14	Mounting insert	304 Stainless steel
15	Indicator insert	Glass-filled PP
16	Index plate	Glass-filled PP

## Key Design Features

The Type 523 Metering Ball Valve utilizes a 180° stroke. An integrated index plate shows the stroke in degrees with an indicator arrow attached to the valve handle. The index plate also shows correct flow direct and while it is removable, it can only be installed on the valve one way because of the design of its interface with the valve body.



The Type 523 Metering Ball features a V-notch design. This type of ball design allows for flow control even at very low flow rates given the size of the valve. The flow characteristics curve is nearly linear because orifice size changes gradually as the valve is opened and closed. This type of V-notch design provides much better flow control, especially at low flow rates, when compared to both keyed orifices and 90° V-notch flow control balls.

# Technical Data

## Pressure Temperature Curves

The following graphs are based on a 25 year lifetime water or similar media application

### PVC

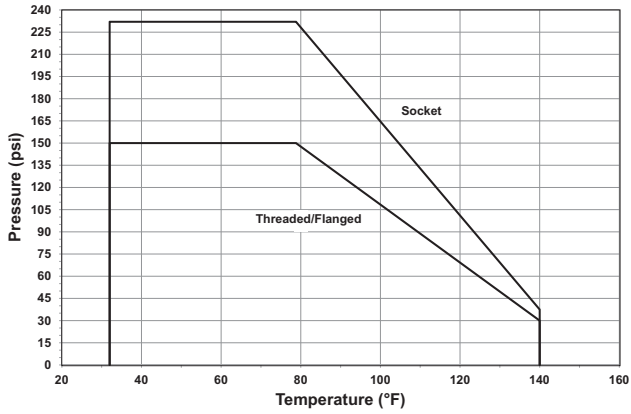

### CPVC

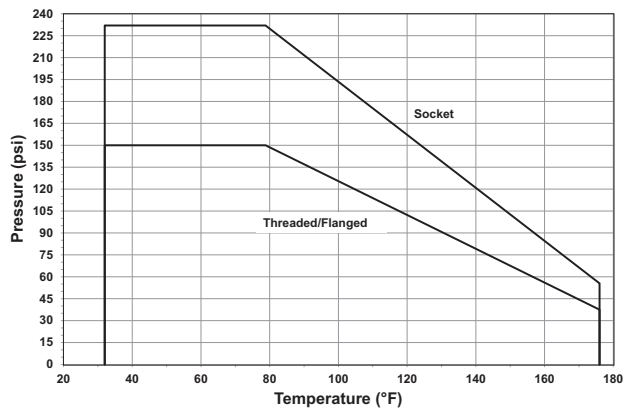

### PP

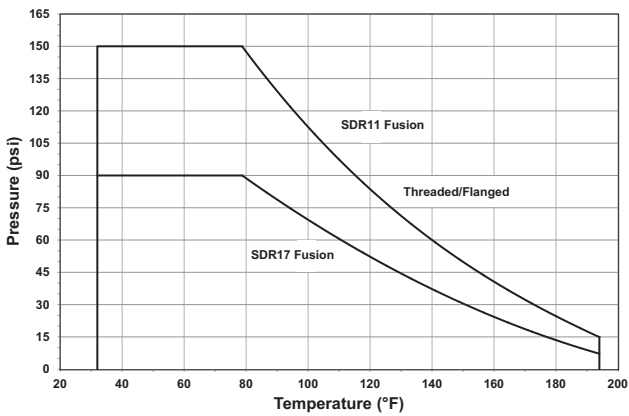

### PVDF

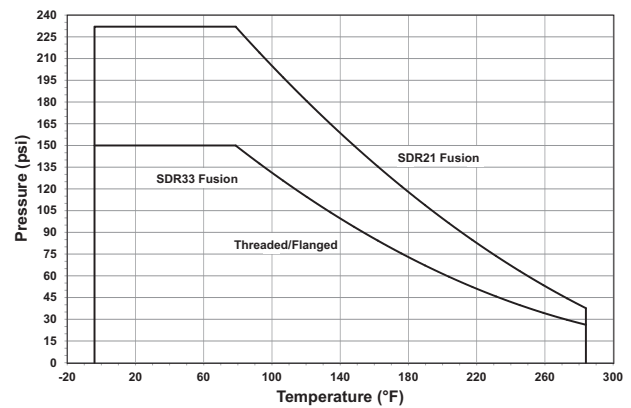

### ABS: Optional Material

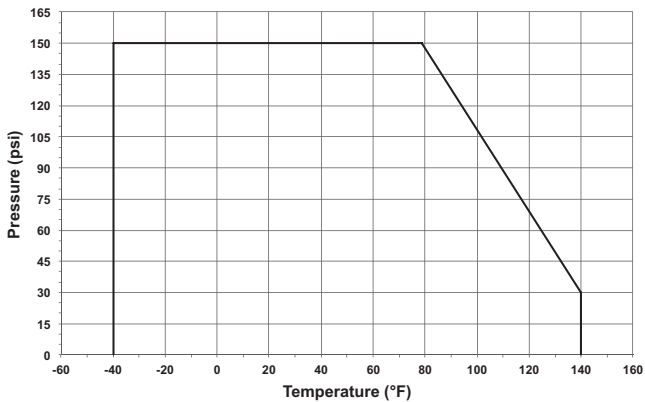

### Pressure-Temperature

Material	Temperature Range (°F)	Max Pressure (psi)
PVC	32 to 140	232
CPVC	32 to 176	232
PP	32 to 176	150
PVDF	-4 to 284	232

For availability, please contact GF

# Flow

The following information is based on water applications at 68° F

## Flow Characteristics

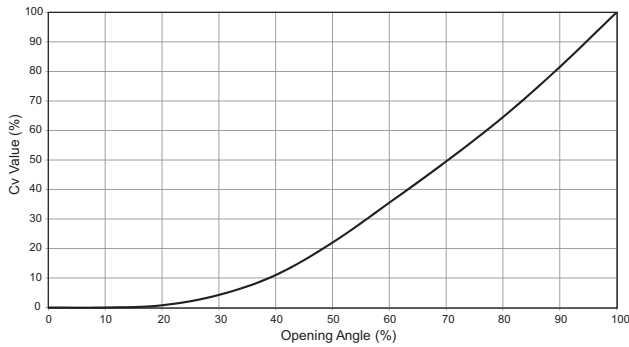

## Cv Value

Size (inch)	d (mm)	Cv (gal/min)
3/8	16	0.8
1/2	20	1.4

# Dimensions

The following tables are shown in millimeters unless otherwise specified.

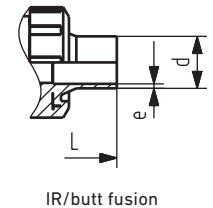
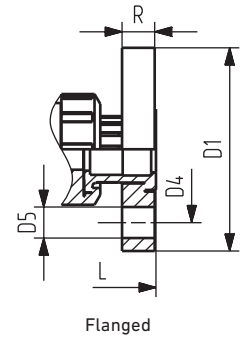
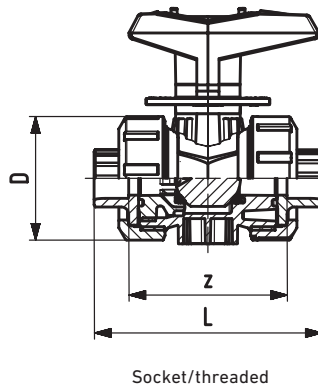
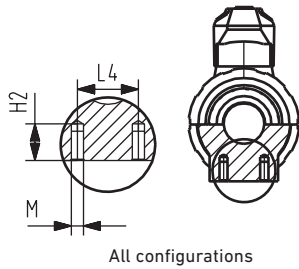

## All Materials

Size (inch)	d (mm)	D	H2	L4	M
3/8	16	50	12	25	M6
1/2	20	50	12	25	M6

## PVC/CPVC

Size (inch)	IPS Socket		Threaded NPT		ANSI Flanged				
	L	z	L	z	L	D1 (inch)	D4 (inch)	D5 (inch)	R (inch)
3/8	105	67	98	69	-	-	-	-	-
1/2	105	61	98	65	149	3.5	2.38	0.5	0.57

## PP

d (mm)	Metric Socket		Metric IR/Butt		Threaded NPT		ANSI Flanged				
	L	z	L	e	L	z	L	D1 (inch)	D4 (inch)	D5 (inch)	R (inch)
16	93	67	-	-	96	71	-	-	-	-	-
20	95	66	130	1.9	99	64	166	3.74	2.36	0.63	0.63

## PVDF

d (mm)	Metric Socket		Metric IR/Butt		Threaded NPT		ANSI Flanged				
	L	z	L	e	L	z	L	D1 (inch)	D4 (inch)	D5 (inch)	R (inch)
16	93	67	-	-	96	69	-	-	-	-	-
20	95	66	130	1.9	99	64	174	3.74	2.36	0.63	0.63