

True Union Ball Valve Type 375

CORZAN®



General

- **Size:** 3/8"–4"
- **Material:** PVC, CORZAN® CPVC, or PPn
- **Seat:** PTFE
- **Seals:** EPDM or FPM
- **End Connection:** Solvent cement socket, threaded, flanged, PPro-Seal™ electrofusion socket
- **Standard Pack Quantity:** 1 valve

Key Certifications

- **NSF 61:** PVC and CPVC
- **USP 25 Class VI (physiological non-toxic):** PP
- **FDA CFR 21 177.1520:** PPn
- **CORZAN:** CPVC

Optional Features

- **Vented Ball:** For sodium hypochlorite use

Sample Specification

The Type 375 Ball Valve shall be true union and utilize a floating ball design. The ball shall be full port with two way blocking capability. The stem shall be blowout proof and utilize a double o-ring seal. The seat carrier shall be adjustable with the handle doubling as a seat carrier adjustment or removal tool. Ball seats shall have an elastomeric backing o-ring and all elastomeric seals shall be of like material. ANSI flanged versions shall meet the ANSI B16.5 150lb standard. All valves shall be tested in accordance to ISO9393 and designed to ISO16135 standards. All valves shall be manufactured under ISO9001 for Quality and ISO14001 for Environmental Management. PVC valves shall meet ASTM D1784 cell classification 12454 standards. CPVC valves shall meet ASTM D1784 cell classification 23447 standards. PPn valves shall meet ASTM D4101 standards. Valves of all materials shall be RoHS compliant.

Components

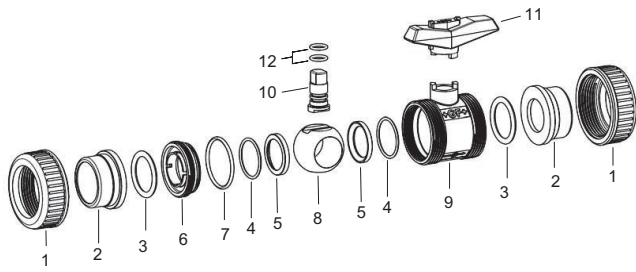

Key Design Features

An arrow is molded on the body of the Type 375 to indicate the side of the valve with a fixed seat. The valve is bidirectional, so the installation direction does not affect the valve's performance. However, the installation direction of the fixed side of the valve does provide benefits for both upstream and downstream installs. When a valve is closed, the ball seal in a pressurized system is provided by the downstream seat, it is therefore advantageous to install the valve with the fixed side downstream. Depending on system design, it can be easier to adjust the seat carrier of a valve if the fixed seat is upstream because the upstream side of the valve does not need to be depressurized.



Valve Components

Part	Description	Material
1	Valve nut	PVC, CPVC or PPn
2	Valve end	PVC, CPVC, PPn or PE
3	Face seal	EPDM or FPM
4	Backing seal	EPDM or FPM
5	Seat	PTFE
6	Seat carrier	PVC, CPVC or PPn
7	Body seal	EPDM or FPM
8	Ball	PVC, CPVC or PPn
9	Body	PVC, CPVC or PPn
10	Stem	PVC, CPVC or PPn
11	Handle	Glass filled PP
12	Stem seal	EPDM or FPM

Material Availability

Material	Range (inch)	Range (mm)
PVC	3/8-4	16-110
CPVC	3/8-2	16-63
PPn	1/2-2	20-63



The Type 375 stem utilizes a redundant O-ring design to provide an added barrier against leak out. It also features an oversized base to prevent blowout.

Vented Ball: Optional Feature

A vented ball is an optional feature with all variations of the Type 375 Ball Valve. This version of the valve has dedicated part numbers that utilize a special ball with a 1/8 inch hole. This ball is designed for applications in which the media requires out-gassing such as sodium hypochlorite. The hole functions as a vent for media that would normally be trapped inside a closed ball. The vent prevents potentially dangerous pressure from building up inside the valve. The vent is located on the seat carrier side of the ball valve and this side is recommended to be installed upstream.

Chemical applications vary from system to system and variations such as concentration, temperature and pressure need to be considered. It is the responsibility of the individual user to verify compatibility and GF recommends that every application be verified and tested by internal experts or a third party.



Technical Data

Pressure Temperature Curves

The following graphs are based on a 25 year lifetime water or similar media application

PVC

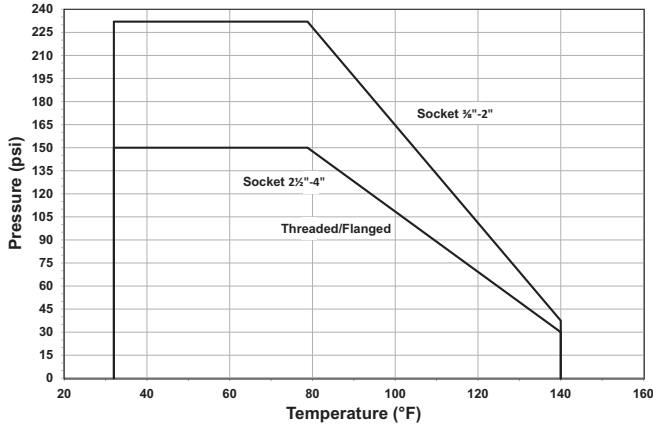

CPVC

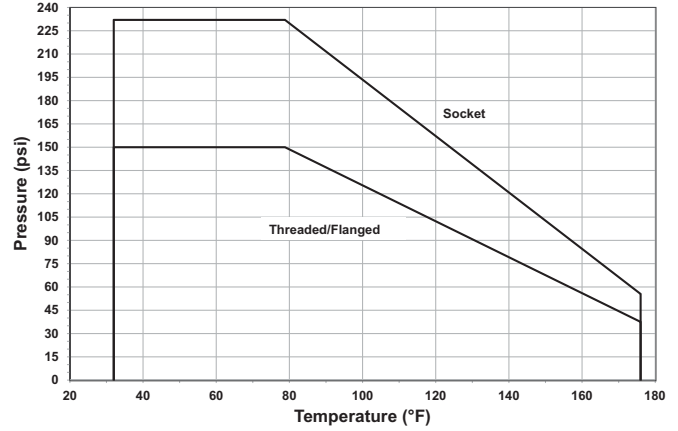

PPn

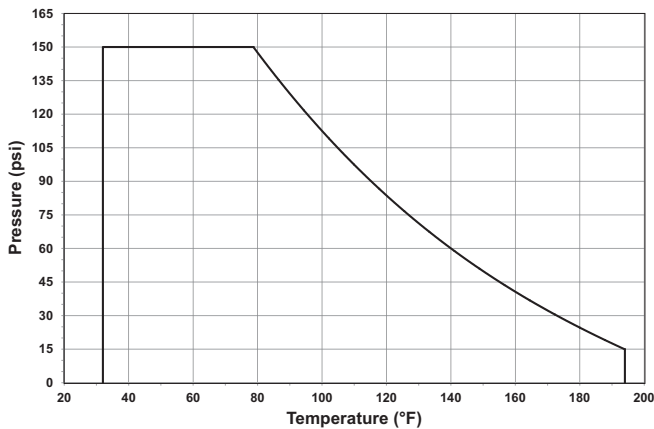

Pressure-Temperature

Material	Temperature Range (°F)	Max Pressure (psi)
PVC	32 - 140	232*
CPVC	32 - 176	232*
PPn	32 - 176	150

*Dependant on end connection as shown in P-T curves

Vacuum Service

The Type 375 is rated for full vacuum service. Maximum differential pressure of 15psi at 122°F.

Flow

The following information is based on water applications at 68° F

Cv Value

Size (inch)	d (mm)	Cv (gal/min)
1/2	20	15
3/4	25	21
1	32	55
1 1/4	40	81
1 1/2	50	126
2	63	245
2 1/2	75	364
3	90	490
4	110	700

Flow Characteristics

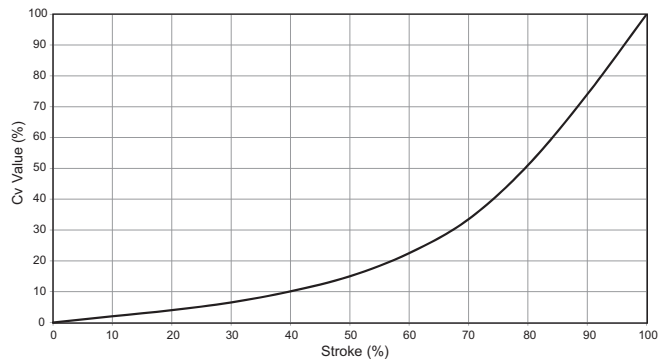

Dimensions

The following tables are shown in millimeters unless otherwise specified

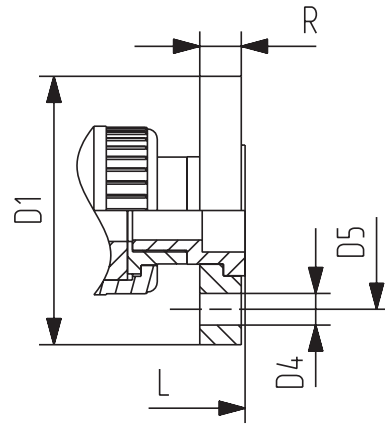
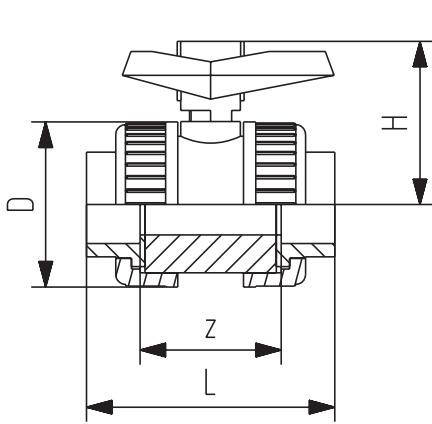

All Materials

Size (inch)	D	H
3/8	50	53
1/2	50	53
3/4	59	60
1	68	67
1 1/4	80	79
1 1/2	94	90
2	115	107
2 1/2	145	129
3	168	143
4	210	169

PPn

Size	PPro-Seal Socket	
	L	z
1/2	98	47
3/4	111	53
1	123	59
1 1/2	149	80
2	171	93
3	244	144

PVC/CPVC

Size	IPS Socket		Threaded NPT		ANSI Flanged				
	L	z	L	z	L	D1 (inch)	D4 (inch)	D5 (inch)	R (inch)
3/8	83	51	73	53	-	-	-	-	-
1/2	91	47	89	55	135	3.5	0.5	2.38	0.57
3/4	104	53	90	59	148	3.88	0.5	2.75	0.58
1	116	59	102	66	167	4.25	0.5	3.13	0.66
1 1/4	131	67	117	75	183	4.63	0.5	3.5	0.69
1 1/2	149	80	127	86	206	5	0.5	3.88	0.76
2	171	93	151	98	239	6	0.63	4.75	0.82
2 1/2	209	118	-	-	287	7	0.63	5.5	0.98
3	244	144	-	-	333	7.5	0.63	6	1.02
4	287	164	-	-	383	9	0.63	7.5	1.11