

Pneumatically Actuated Ball Valve Type 230-233



General

- **Size:** 3/8"–4"
- **Material:** PVC, CPVC, PROGEF® Standard PP, ABS, SYGEF® Standard PVDF
- **Seat:** PTFE
- **Seals:** EPDM, FPM
- **End Connection:** Solvent cement socket, threaded, flanged, fusion spigot, fusion socket
- **Actuator Housing 3/8"–2":** Glass-filled PP
- **Actuator Housing 2 1/2"–4":** Anodized aluminum
- **Manual Override 3/8"–2":** Standard versions with and without
- **Stroke Limiter 2 1/2"–4":** Integrated, ±10°
- **Mounting:** Stainless steel threaded inserts
- **Action:** Fail open, fail closed, and double acting
- **Position Indicator:** Optical, integrated

Sample Specification

The Type 230-233 Ball Valve shall be used in either open/close or modulating applications. The actuator shall be a PA11-45 depending on valve size. The ball valve shall be true union and utilize a floating ball design. The ball shall be fully molded and full port with two way blocking capability. The stem shall be blowout proof, utilizing a double o-ring seal and a predetermined break point opposite the media side of the stem seals. The seat carrier shall be adjustable and reverse threaded. The valve nut threads shall be of buttress type. Ball seats shall have an elastomeric backing o-ring and all elastomeric seals shall be of like material. ANSI flanged versions shall meet ANSI B16.5 150lb standards. All valves shall be tested in accordance to ISO9393 and designed to ISO16136 standards. All valves shall be manufactured under ISO9001 for Quality and ISO14001 for Environmental Management. Following manual assembly, every valve shall be tested and certified bubble tight exceeding Class VI standards. Following actuated assembly, every valve shall be tested to confirm functionality.

Material Specification

PVC valves shall meet ASTM D1784 cell classification 12454 standards. CPVC valves shall meet ASTM D1784 cell classification 23447-B standards. PP valves shall meet ASTM D5847-14 cell classification PP0510B66851 standards. ABS valves shall meet ASTM D3965 cell classification 42222 standards. PVDF valves shall be type 1, grade 2 according to ASTM D3222 standards. Valves of all materials shall be RoHS compliant.

Key Valve Certifications

- **NSF 61:** PVC and CPVC
- **FDA CFR 21 177.1520:** PP and PVDF
- **FDA CFR 21 177.2600:** EPDM and FPM
- **FDA CFR 21 177.1550:** PTFE
- **ABS:** All materials

Components

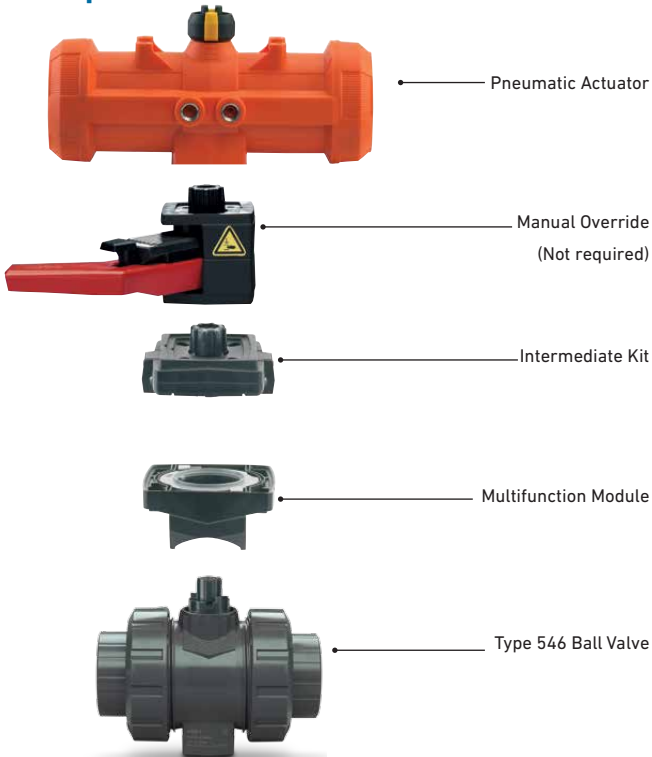

Key Design Feature



The Type 230-233 stem utilizes a pre-determined break point opposite the media side of the stem seals. This break point is a groove with an inner diameter that is less than the stem seal grooves. This ensures that if there is a stem failure, the failure will occur at that point and media will not leak to the outside of the valve.

Optional Features

- **Pilot Valve:** 24VAC/DC, 110VAC, 230VAC
- **Positioner:** Digital electro-pneumatic
- **Limit Switches:** Mechanical, inductive
- **Actuator Housing:** Alternative materials available upon request
- **Manual Override 2½"-4":** Declutchable
- **Stroke Limiter ¾"-2":** ±45°
- **Manual Loading Station:** Local control box
- **Seats:** Alternative materials available upon request
- **Seat:** PVDF
- **End Connection:** Alternatives available upon request
- **Control Ball:** For throttling applications available ¾"-2"
- **Vented Ball:** For sodium hypochlorite use
- **Cleaned:** Silicone free/oil free

Definition of Valve Type

- **Type 230:** ABS
- **Type 231:** PP
- **Type 232:** PVDF
- **Type 233:** PVC/CPVC

Key Design Feature

The Type 230-233 seat carrier is reverse threaded while the valve nut utilizes a standard thread. This ensures that the seat carrier is not inadvertently tightened when the valve nut is tightened thus avoiding an overtightening of the seat carrier which can cause several issues but the most common failure is stem breakage. This design feature is especially beneficial in pneumatically actuated applications where valves are rapidly cycled and valve stems endure high levels of induced stress.

A manual valve handle is included with Type 230-233 valves assembled by GF and doubles as a seat carrier adjustment tool by simply inserting the handle clip into the pre-molded notches on the seat carrier, making on-site maintenance quick and easy.



Actuator Technical Data

	PA 11/21	PA 30-45
Actuator Style	Rack and pinion	Scotch yoke
Control Media	Neutral, non aggressive gases (max. 104°F)	Neutral, non aggressive gases (max. 104°F)
Max. Allowable Control Pressure	100 psi	100 psi
Pneumatic Connection	1/8" BSP (NPT adapter supplied)	1/8" BSP (NPT adapter supplied) Namur compliant
Cycle Time	1-2 seconds	1-2 seconds
Actuation Angle	90°	90°
Action	Fail-safe close (FC) Fail-safe open (FO) Double acting (DA)	Fail-safe close (FC) Fail-safe open (FO) Double acting (DA)
Operating Temperature	14°F - 122°F	14°F - 176°F
Permissible Humidity	0-100%	0-95%
Position Indicator	Visual	Visual
Housing Material	PP-glass filled	Anodized aluminum

Actuator Type by Valve Size

	3/8	1/2	3/4	1	1 1/4	1 1/2	2	2 1/2	3	4
Fail-safe Close (FC)	PA 11	PA 11	PA 11	PA 11	PA 21	PA 21	PA 21	PA 30	PA 40	PA 40
Fail-safe Open (FO)	PA 11	PA 11	PA 11	PA 11	PA 21	PA 21	PA 21	PA 30	PA 40	PA 40
Double Acting (DA)	PA 11	PA 11	PA 11	PA 11	PA 21	PA 21	PA 21	PA 35	PA 45	PA 45

Min. Operating Air Pressure (psi)

	3/8	1/2	3/4	1	1 1/4	1 1/2	2	2 1/2	3	4
Fail-safe Close (FC)	60	60	60	60	60	60	60	43	60	60
Fail-safe Open (FO)	60	60	60	60	60	60	60	43	60	60
Double Acting (DA)	60	60	60	60	60	60	60	43	43	72

Technical Data

Flow

The following information is based on water applications at 68° F

Cv Value

Size (inch)	d (mm)	Cv (gal/min)
3/8	16	4.9
1/2	20	12.9
3/4	25	24.5
1	32	49.0
1 1/4	40	70.0
1 1/2	50	112.0
2	63	217.1
2 1/2	75	350.0
3	90	490.0
4	110	770.0

Flow Characteristics

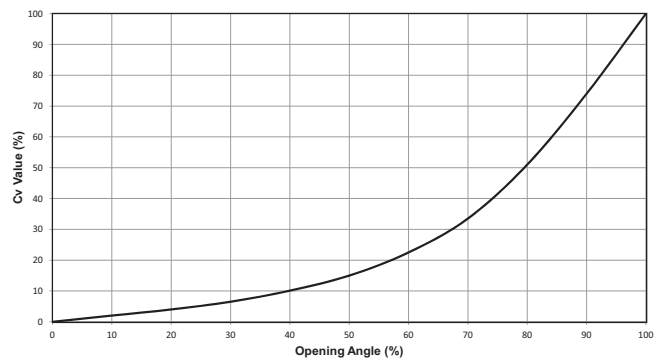

Technical Data

Pressure Temperature Curves

The following graphs are based on a 25 year lifetime water or similar media application

PVC

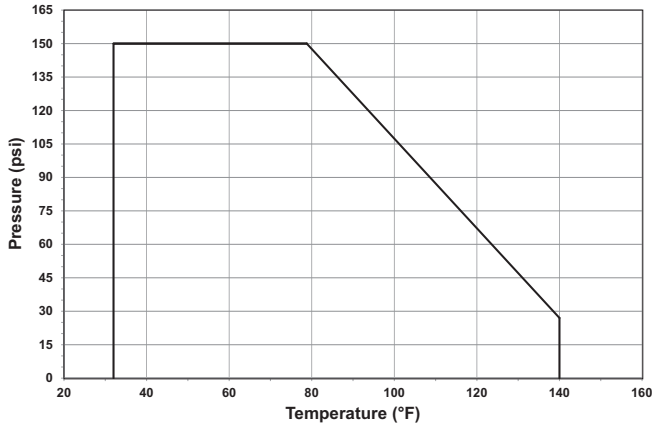

CPVC

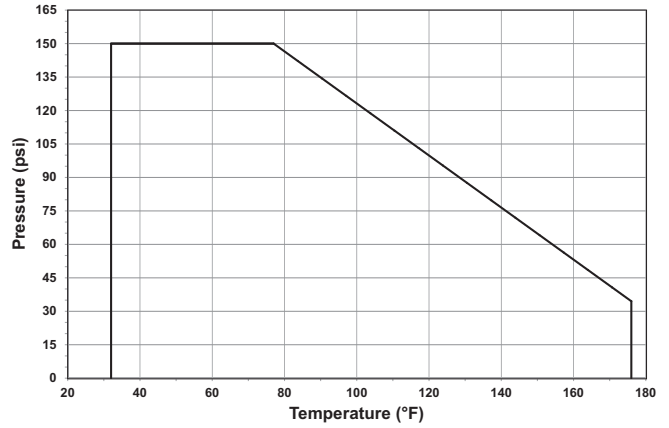

PP

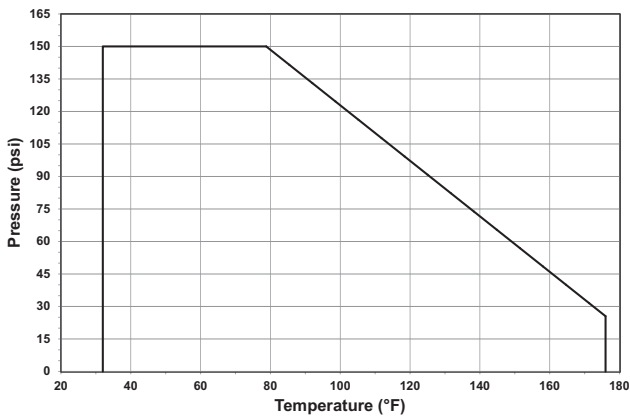

ABS

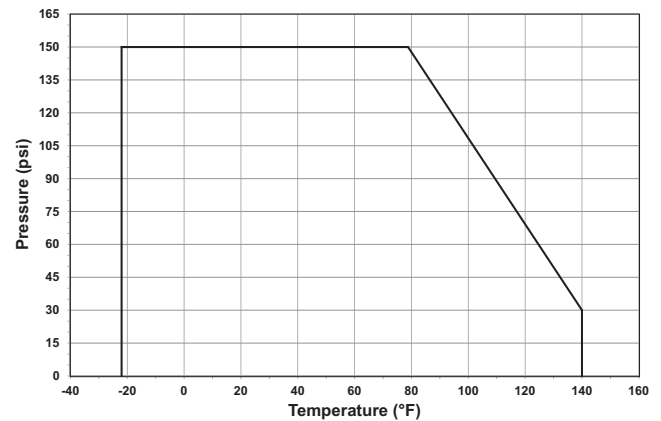

PVDF

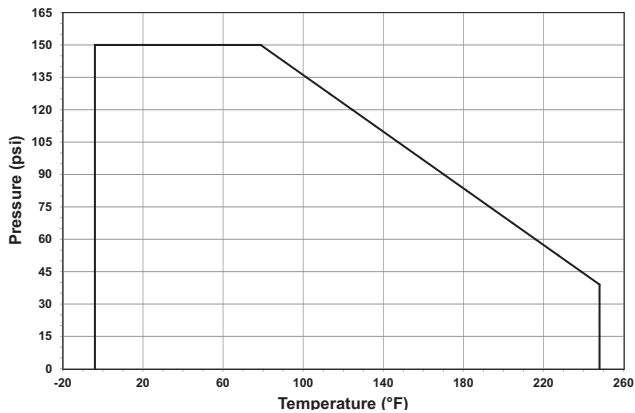

Pressure-Temperature

Material	Temperature Range (°F)	Max Pressure (psi)
PVC	32 to 140	150
CPVC	32 to 176	150
PP	32 to 176	150
ABS	-40 to 140	150
PVDF	-4 to 284	150

Vacuum Service

The Type 230-233 is rated for full vacuum service. Maximum differential pressure of 15psi at 122°F.

Dimensions

The following tables are shown in millimeters unless otherwise specified

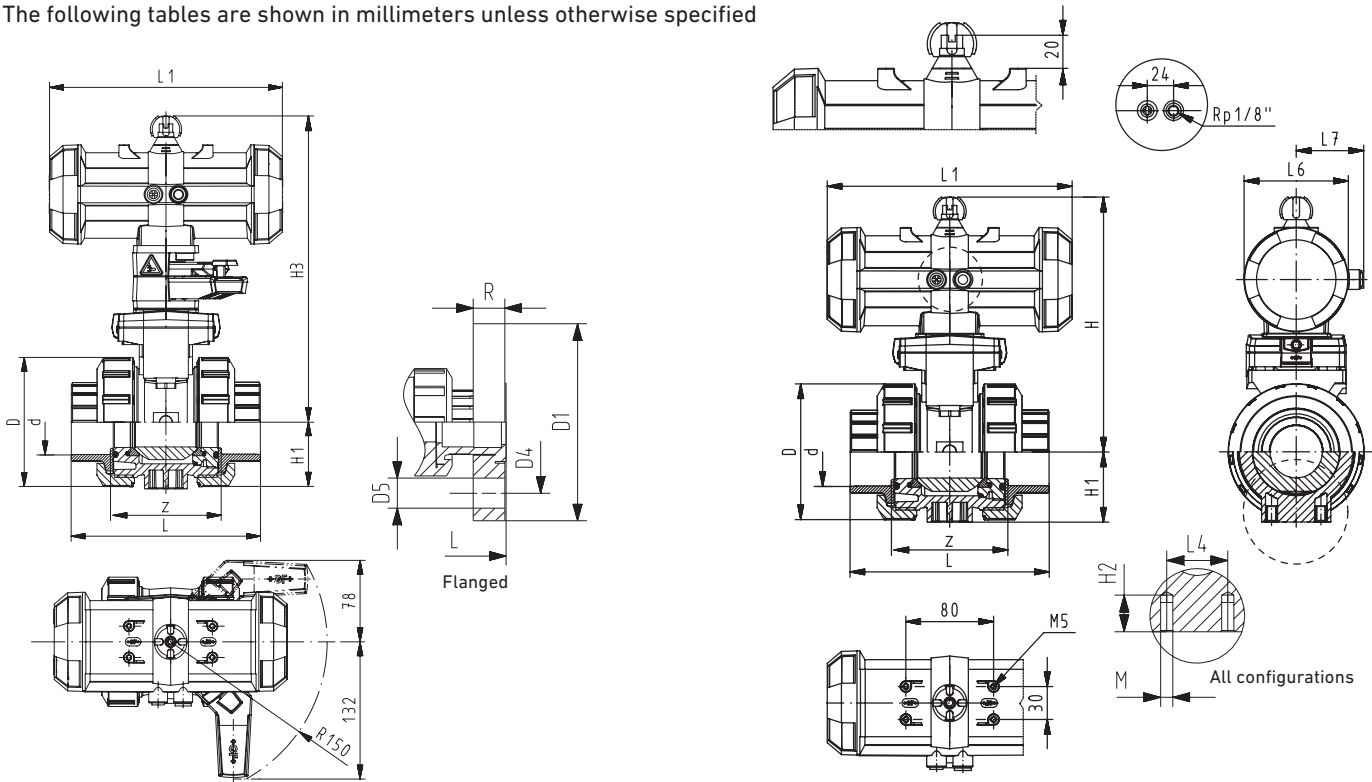

All Materials

Size (inch)	d (mm)	D	H	H1	H2	H3	L1 (SR/DA)	L4	L6 (SR/DA)*	L7 (SR/DA)*	M
3/8	16	50	167	27	12	230	194	25	76	48	M6
1/2	20	50	167	27	12	230	194	25	76	48	M6
3/4	25	58	176	30	12	239	194	25	76	48	M6
1	32	68	176	36	12	239	194	25	76	48	M6
1 1/4	40	84	210	44	15	271	224	45	95	59	M8
1 1/2	50	97	210	51	15	271	224	45	95	59	M8
2	63	124	232	64	15	293	224	45	95	59	M8
2 1/2	75	166	262	85	15	-	276/326	70	65/72	32.5/36	M8
3	90	200	281	105	15	-	370/411	70	80/90	40/45	M8
4	110	238	238	123	22	-	370/411	120	80/90	40/45	M12

*SR=Spring return (Fail-open/fail-close) DA=double acting. If only one dimension is shown they are both the same.

PVC/CPVC

Size (inch)	IPS Socket		Threaded NPT		ANSI Flanged					
	L	z	L	z	L	D1 (inch)	D4 (inch)	D5 (inch)	R (inch)	
3/8	105	67	98	69	-	-	-	-	-	
1/2	105	61	98	65	149	3.5	2.38	0.63	0.57	
3/4	121	70	111	74	165	3.88	2.75	0.63	0.58	
1	133	76	127	82	184	4.25	3.13	0.63	0.66	
1 1/4	154	90	147	98	206	4.63	3.5	0.63	0.69	
1 1/2	164	94	157	110	221	5	3.88	0.63	0.76	
2	183	107	183	135	251	6	4.75	0.63	0.82	
2 1/2	233	144	234	166	311	7	5.5	0.75	0.98	
3	254	151	255	175	343	7.5	6	0.75	1.02	
4	301	174	302	214	397	9	7.5	0.75	1.11	

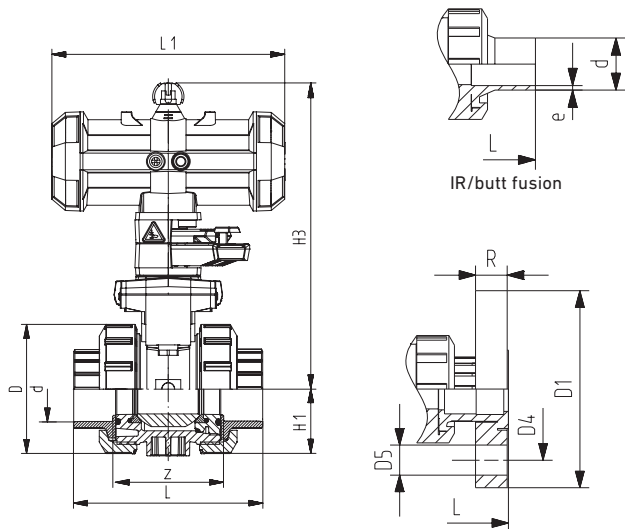

ABS

d (mm)	Metric Socket	
	L	z
16	92	64
20	95	64
25	110	72
32	123	79
40	146	94
50	157	95
63	183	107
75	233	144
90	254	151
110	301	174

PP

d (mm)	Metric Socket		Metric IR/Butt		Threaded NPT		ANSI Flanged				
	L	z	L	e	L	z	L	D1 (inch)	D4 (inch)	D5 (inch)	R (inch)
16	93	67	-	-	96	71	-	-	-	-	-
20	95	66	130	1.9	99	64	166	3.74	2.36	0.63	0.63
25	109	77	143	2.3	111	76	177	4.13	2.76	0.63	0.67
32	119	83	150	2.9	127	83	191	4.53	3.11	0.63	0.71
40	135	99	171	3.7	146	100	209	5.51	3.5	0.63	0.79
50	147	105	191	4.6	157	111	229	5.91	3.86	0.63	0.87
63	168	117	220	5.8	183	134	253	6.5	4.76	0.75	0.94
75	233	167	266	6.8	-	-	416	7.28	5.51	0.75	1.02
90	254	180	264	8.2	-	-	414	7.87	5.98	0.75	1.06
110	301	215	301	10.0	-	-	451	9.02	7.48	0.75	1.1

PVDF

d (mm)	Metric Socket		Metric IR/Butt		Threaded NPT		ANSI Flanged				
	L	z	L	e	L	z	L	D1 (inch)	D4 (inch)	D5 (inch)	R (inch)
16	93	67	-	-	96	69	-	-	-	-	-
20	95	66	130	1.9	99	64	174	3.74	2.36	0.63	0.63
25	109	77	143	1.9	111	76	189	4.13	2.76	0.63	0.67
32	119	83	150	2.4	127	83	199	4.53	3.11	0.63	0.71
40	135	99	171	2.4	146	101	235	5.51	3.5	0.63	0.79
50	147	105	191	3.0	157	111	243	5.91	3.86	0.63	0.87
63	168	117	220	3.0	183	135	261	6.5	4.76	0.75	0.94
75	233	167	266	3.6	-	-	426	7.28	5.51	0.75	1.02
90	254	180	264	4.3	-	-	426	7.87	5.98	0.75	1.06
110	301	215	301	5.3	-	-	487	9.02	7.48	0.75	1.1