

# Electrically Actuated Wafer Butterfly Valve Type 145



## General

- Size: 2"–12"
- Outer Body: Glass-filled PP
- Material: PVC, CPVC, PROGEF® Standard PP, ABS, SYGEF® Standard PVDF
- Seals: EPDM, FKM, PTFE/FKM
- Stem: 316 stainless steel
- Voltage: 100-230VAC, 24VAC/DC
- Connection: Both ANSI 150 and DIN 2501
- Actuator Housing: Glass-filled PP
- Manual Override: Integrated
- End Stops: Open, close, programmable middle position
- Position Indicator: LED, optical, integrated
- Position Feedback: Open, close, middle
- Heater: 10 position adjustable

## Sample Specification

The Type 145 Electrically Actuated Butterfly Valve shall be wafer style compatible with both ANSI B16.5 150 lb and DIN 2501 flange patterns. The disk operation shall utilize double eccentric design principles. The shaft shall be non-wetted by a bushing assembly with double O-ring seals and fixed at both ends. The face seal shall be a Q-ring compatible with flat and serrated flange adapters. The face, disk and shaft seals shall operate independently. The wetted body and disk shall be of like materials. Valves shall be rated for bidirectional use. All valves shall be tested in accordance to ISO9393 and designed to ISO16136 standards. All valves shall be manufactured under ISO9001 for Quality and ISO14001 for Environmental Management. Following assembly, every valve shall be tested and certified bubble tight exceeding Class VI standards.

## Material Specification

PVC valves shall meet ASTM D1784 cell classification 12454 standards. CPVC valves shall meet ASTM D1784 cell classification 23447-B standards. PP valves shall meet ASTM D5847-14 cell classification PP0510B66851 standards. ABS valves shall meet ASTM D3965 cell classification 42222 standards. PVDF valves shall be type 1, grade 2 according to ASTM D3222 standards. Valves of all materials shall be RoHS compliant.

## Key Valve Certifications

- NSF 61: PVC and CPVC
- FDA CFR 21 177.1520: PP and PVDF
- FDA CFR 21 177.2600: EPDM and FKM
- FDA CFR 21 177.1550: PTFE
- ABS: All materials
- USP Class VI (physiological non-toxic): EPDM, FKM, PTFE, PP and PVDF

## Components

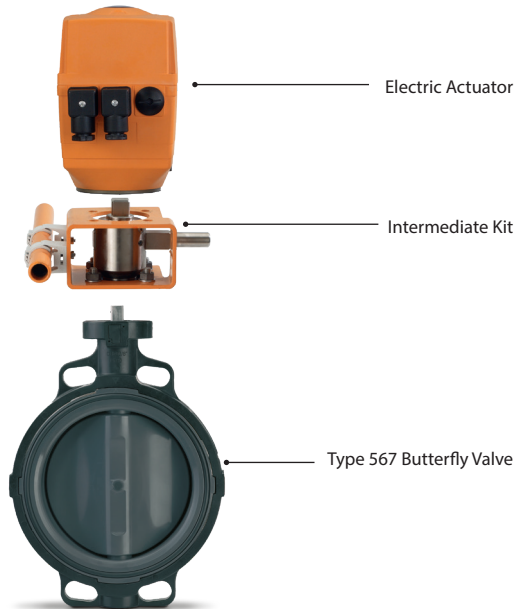

### Heater Dial Selector

Dial Setting	Heater Turned On (°F)	Heater Turned Off (°F)
0 (default)	32	41
1	41	50
2	50	59
3	59	68
4	68	77
5	77	86
6	86	95
7	95	104
8	104	113
9	104	113

## Optional Features

- Positioner: Current, voltage
- Network: Profibus DP
- Fail Safe Return: Battery back up, externally powered board
- Smart Module: Cycle monitoring, cycle counter, cycle time extension, motor current monitoring
- Manual Loading Station: Local control box
- Stem Extension: Two piece stainless steel
- Shaft: Titanium, Hastelloy-C
- Hardware: Alternatives available upon request
- Cleaned: Silicone free/oil free

## Actuator Certifications/Compliance

- Machinery Directive 2006/42/EC, Annex II B
- EMV Directive CE 2004/108/CE
- EMV VDE 0843 Section 20
- Low Voltage Directive CE 2006/95/CE
- Vibration Testing EN 60068-2-6
- Actuators for Industrial Valves EN 15714-2

## Key Design Feature

### Heater

An adjustable heater is integrated into the Type 145 Valve to protect the actuator subcomponents in cold applications and to prevent water from condensing inside the actuator housing in humid environments. The heater will turn on when the actuator's internal temperature reaches a designated value and turn off after it has heated to a designated value. These parameters can be adjusted by rotating the arrow on the dial selector shown below.

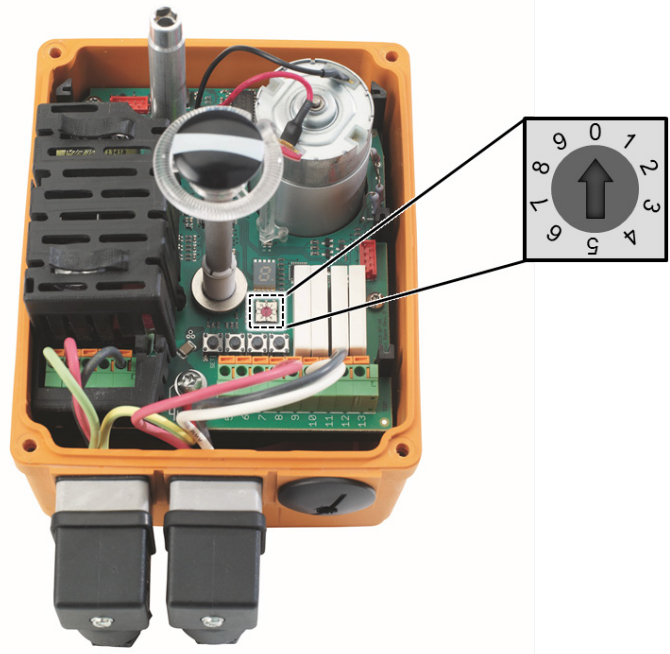

# Actuator Technical Data

	EA 45	EA 120	EA 250
Valve Size (w/o MO)	2"-2½"	3"-6"	8"-12"
Valve Size (w/ MO)	2" - 2 1/2"	2" - 6"	8" - 12"
Cycle Time	6s/90°	15s/90°	20s/90°
Rated Cycles at 70°F	100,000	100,000	75,000
Actuating Angle	Standard set at 90°, max. 355°		
Housing Material	Glass-filled PP		
Position Feedback	230V, 6 Amp		
Emergency Manual Override	Integrated		
Rated Voltage	100- 230V, 50/60 Hz 24V, AC/DC, 50/60Hz		
Rated Voltage Tolerance	+/- 15%		
Rated Output	55VA @ 100-230VAC 60VA @ 24VAC/DC	50VA @ 100-230VAC 55VA @ 24VAC/DC	60VA @ 100-230VAC 65VA @ 24VAC/DC
Duty Cycle	50%	50%	35%
Protection Class	IP 67 per EN 60529 UL/CSA Nema 4X		
Overload Protection	Resetting, current-time dependant (1)		
Overvoltage Category	Category II according to DIN EN 61010-1		
Power Connection	Connector plug 3 P+ E per DIN EN 175301-03		
Pollution Grade	Grade 2 according to DIN EN 61010-1		
Maximum Elevation	6561 feet		
Ambient Temperature	14° to 122°F (2)		
Allowable Humidity	90% relative humidity, non condensing		

(1) Overload protection of the motor is dimensioned so that the motor and the power supply board are protected. As soon as the load is within the torque range, the actuator will begin operating again.  
 (2) At temperatures below 14°F and if there is condensation, the heating element should be activated.

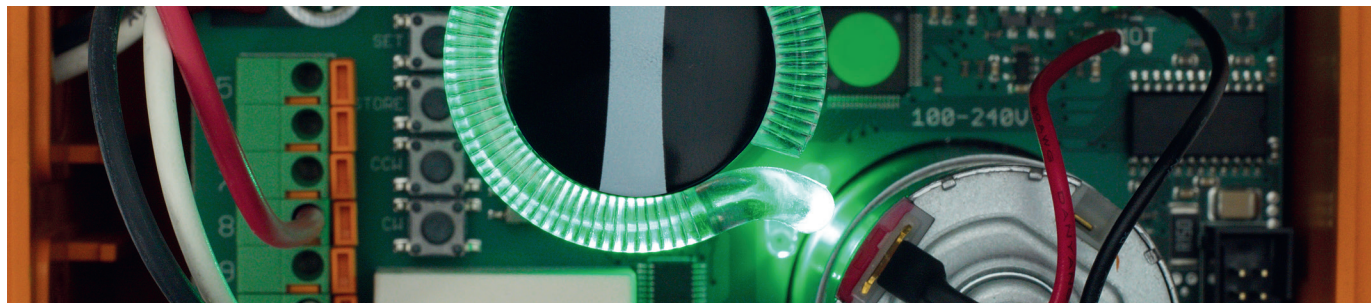

## Wiring Diagrams

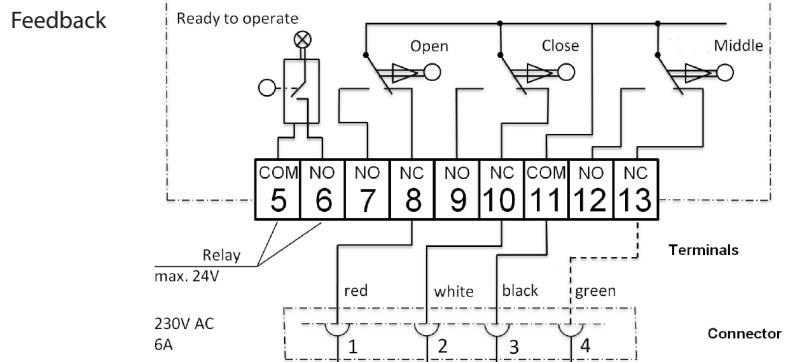
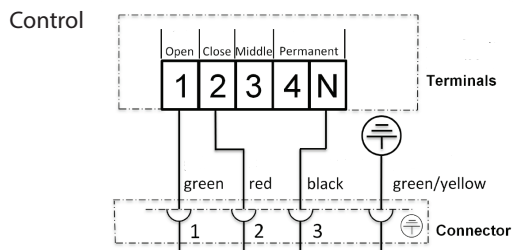

## Key Design Features

The Type 145 Butterfly Valve utilizes several design features to protect electric actuators and increase the useful life of the valve.

### Seals

The shaft is sealed with a bushing assembly on either side of the disc. Each bushing utilizes a double o-ring seal totaling eight shaft seals in every valve. Alternative o-ring shaft sealing designs are commonly found in competitive boot style thermoplastic butterfly valves. However, these solutions often rely upon elastomer on elastomer seals which can be unreliable, especially in chemical process applications or when working temperatures deviate from standard conditions. The Type 145 shaft seal design eliminates the need elastomer on elastomer seals, providing an industry tested dynamic double o-ring seal against a ridged thermoplastic surface.

The shaft, disc and face seals all operate independently from one another. This eliminates issues common to booted style centric valves such as crimping, where the compression of the valve between two flanges causes the boot to ripple. This can lead to increased operating torque and burn out electric actuators

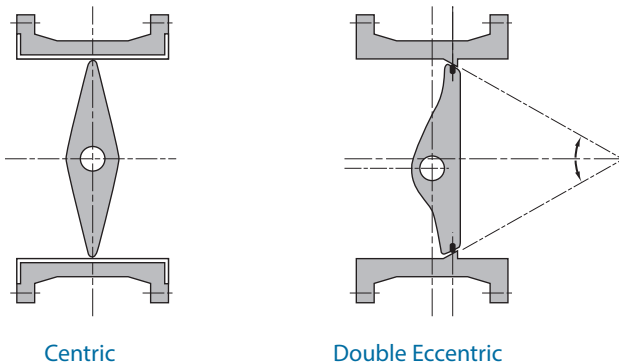

Centric

Double Eccentric

### Double Eccentric Design Principle

The Type 145 Butterfly Valve is designed using the double eccentric disc principle. When opening and closing, the disc is not in contact with the seat, significantly reducing component wear. This design principle greatly reduces the operating torque and required elastomeric sealing material. The reduction in sealing material decreases the impact of elastomeric swelling which can lead to increased operating torque and can cause electric actuators to burn out.

## Technical Data

### Flow

The following information is based on water applications at 68° F

#### Cv Value

Size (inch)	d (mm)	Cv (gal/min)
2	63	103
2½	75	154
3	90	210
4	110	455
5	140	805
6	160	1162
8	225	2772
10	280	3570
12	315	5110

#### Flow Characteristics

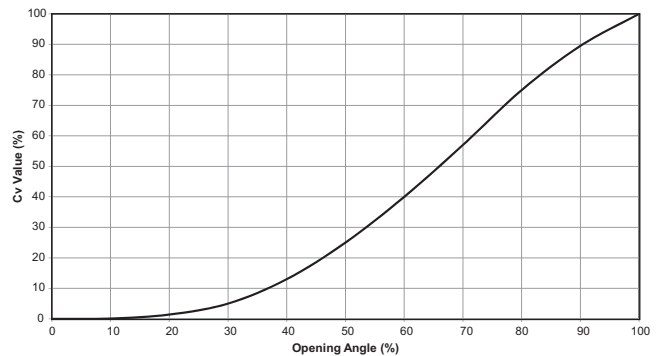

# Technical Data

## Pressure Temperature Curves

The following graphs are based on a 25 year lifetime water or similar media application

### PVC

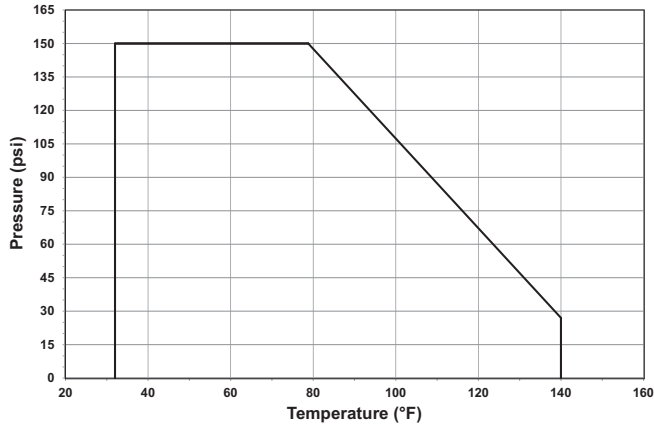

### CPVC

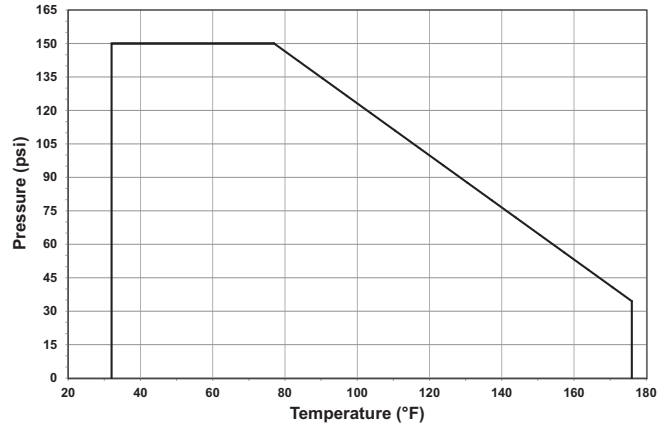

### PP

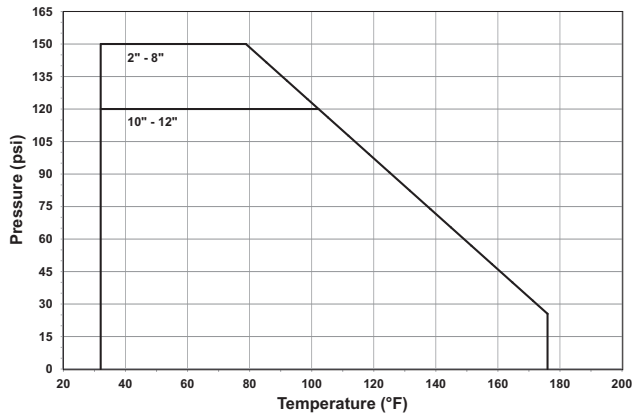

### ABS

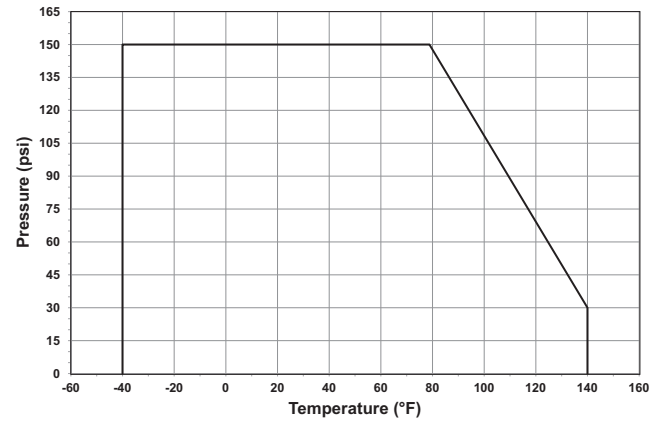

### PVDF

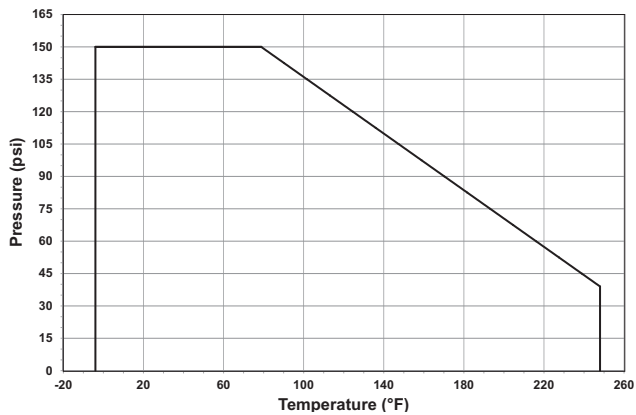

### Pressure-Temperature

Material	Temperature Range (°F)	Max Pressure (psi)
PVC	32 to 140	150
CPVC	32 to 176	150
PP	32 to 176	150*
ABS	-40 to 140	150
PVDF	-4 to 248	150

\*Dependant on size as shown in P-T curves

### Vacuum Service

The Type 145 is rated for full vacuum service. Maximum differential pressure of 15psi at 122°F.

# Dimensions

The following tables are shown in millimeters unless otherwise specified

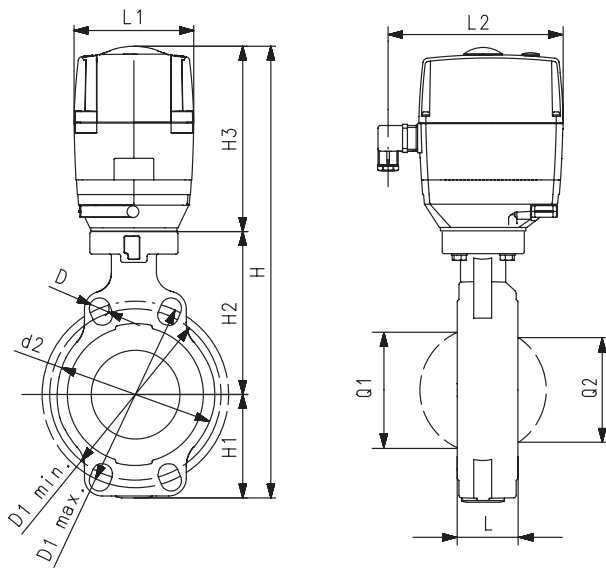

All Materials w/o Manual Override

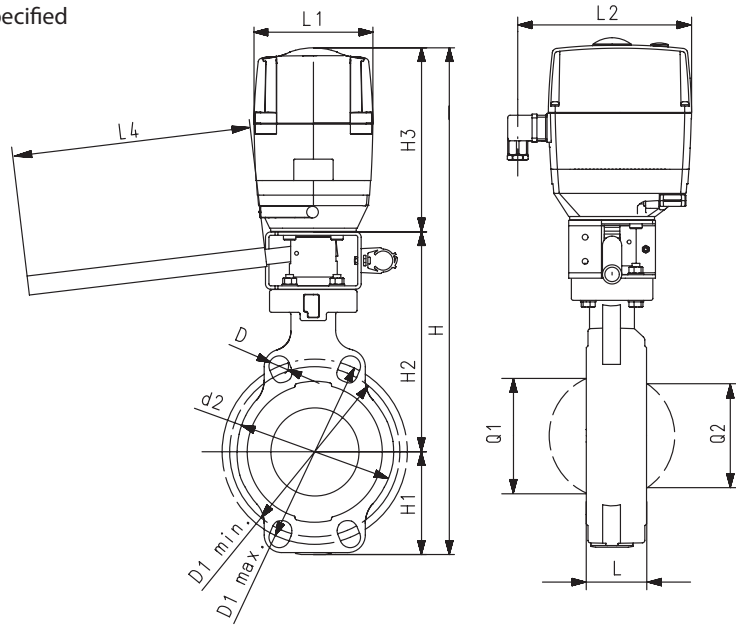

All Materials w/ Manual Override

## All Materials without Manual Override

Size (inch)	d2	D	D1 min	D1 max	H	H1	H2	H3	L	L1	L2	Q1	Q2
2	104	19	120	125	415	77	134	188	45	122	180	40	-
2½	115	19	140	145	428	83	140	188	46	122	180	54	35
3	131	19	150	160	428	89	146	188	49	122	180	67	50
4	161	19	175	191	460	104	167	188	56	122	180	88	74
5	187	23	210	216	487	117	181	188	64	122	180	113	97
6	215	24	241	241	508	130	189	188	72	122	180	139	123
8	267	23	290	295	575	158	210	208	73	122	180	178	169
10	329	25	353	362	677	205	264	208	113	122	180	210	207
12	379	25	400	432	721	228	285	208	113	122	180	256	253

## All Materials with Manual Override

Size (inch)	d2	D	D1 min	D1 max	H	H1	H2	H3	L	L1	L2	L4	Q1	Q2
2	104	19	120	125	475	77	134	188	45	122	180	200	40	-
2½	115	19	140	145	488	83	140	188	46	122	180	200	54	35
3	131	19	150	160	488	89	146	188	49	122	180	200	67	50
4	161	19	175	191	520	104	167	188	56	122	180	250	88	74
5	187	23	210	216	547	117	181	188	64	122	180	250	113	97
6	215	24	241	241	568	130	189	188	72	122	180	250	139	123
8	267	23	290	295	635	158	210	208	73	122	180	250	178	169