

Electrically Actuated Ball Valve Type 104



General

- **Size:** ½"–2"
- **Material:** PVC, CPVC, ABS
- **Seat:** PTFE
- **Seals:** EPDM or FPM
- **End Connection:** Solvent cement socket, threaded
- **Actuator Housing:** Glass-filled PP
- **Voltage:** 110 VAC, 220 VAC, 24 VDC
- **Duty cycle:** 75%
- **Limit Switches:** Two SPST 5A

Optional Features

- **Voltage:** 12VAC, 12VDC, or 24VAC
- **End Connection:** Flanged

Key Certifications

- **NSF 61:** PVC and CPVC

Sample Specification

The Type 104 Ball Valve shall be true union and utilize a floating ball design. The actuator shall be single voltage with a manual override. Two position switches for feedback shall be standard. The ball shall be fully molded and full port with two way blocking capability. The stem shall be blowout proof, utilizing a double o-ring seal and a predetermined break point opposite the media side of the stem seals. The seat carrier shall be adjustable and reverse threaded. The handle shall double as a seat carrier adjustment or removal tool. The valve nut threads shall be of buttress type. Ball seats shall have an elastomeric backing o-ring and all elastomeric seals shall be of like material. ANSI flanged versions shall meet ANSI B16.5 150lb standards. All valves shall be tested in accordance to ISO9393 and designed to ISO16135 standards. All valves shall be manufactured under ISO9001 for Quality and ISO14001 for Environmental Management. Following assembly, every valve shall be tested and certified bubble tight exceeding Class VI standards.

Actuator Technical Data



EA 04	110 VAC	220 VAC	24 V DC
Nominal Torque	14.8 ft-lb		
Peak Torque	18.4 ft-lb		
Control Time	7 seconds/90° ±10% without load		
Actuating Angle	90° – 270°		
L/W/H (Actuator Only)	7.0"/4.1"/5.2"		
Housing Materials	Polyamide		
Position Indicator	Optical, integrated		
Emergency Manual Override	Integrated, standard		
Rated Voltage +5%	110 VAC, 50/60 Hz	220 VAC, 50/60 Hz	24 VDC, 50/60 Hz
Consumption at Peak Torque	0.15 A - 33 W, +/- 5%	0.15 A - 33 W, +/- 5%	0.55 A - 13.2 W, +/- 5%
Duty Cycle	75% at 77°F/15 min		
Protection Class	IP 65		
Power Connector Plug	3 P+ E per DIN EN 175301-03		
Limit switch Connector Plug	DIN 3337 (mini DIN)		
Weight	3.8 Pounds		
Limit Switches	2 SPDT Micro, 5A 250V		
Ambient Temperature	-4° – 158°F		

Important Note: Some residual voltage may be present on the closed terminal when the valve is in the open state and on the open terminal when in the closed state. For position indication the auxiliary limit switches should be used. The power terminals should not be used for position indication.

Wiring Diagrams

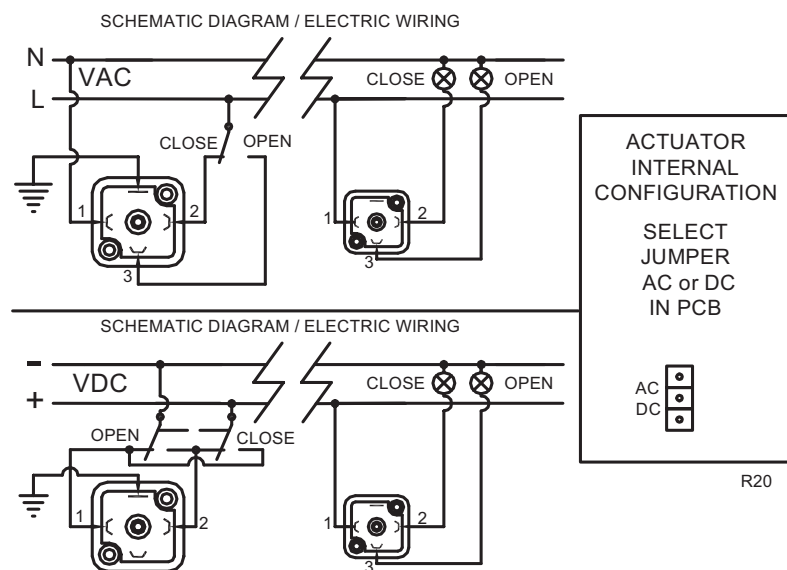

Converting from AC to DC Power

The Type 104 features a jumper connection on the main board that allows an operator to change the accepted incoming voltage from AC to DC power or vice versa. The 24V actuators come with the jumper set to DC in standard assemblies

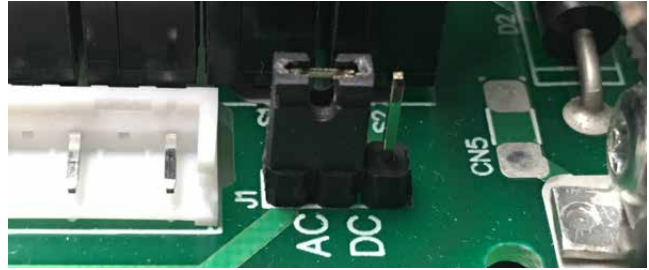

Technical Data

Pressure Temperature Curves

The following graphs are based on a 25 year lifetime water or similar media application

PVC

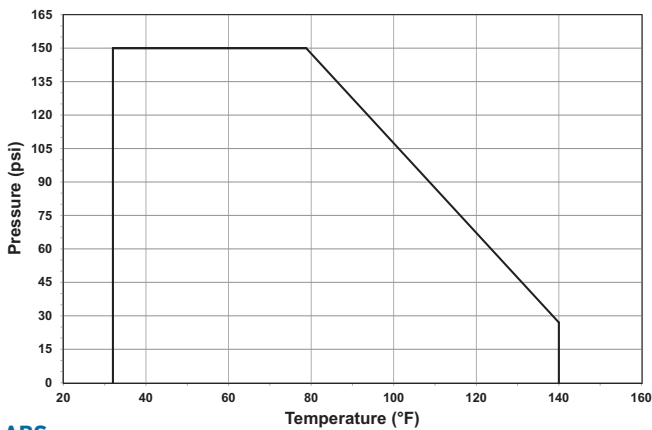

CPVC

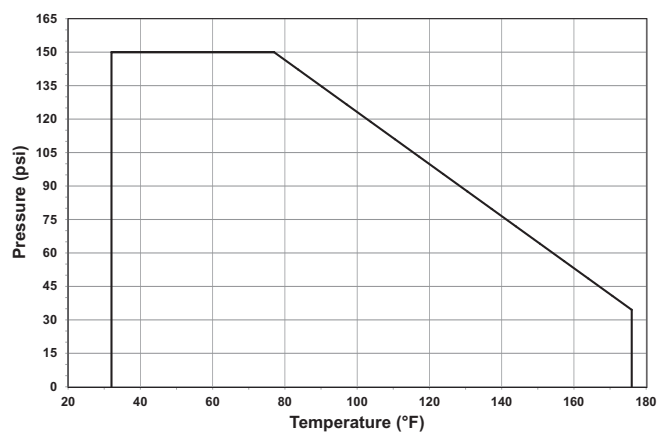

ABS

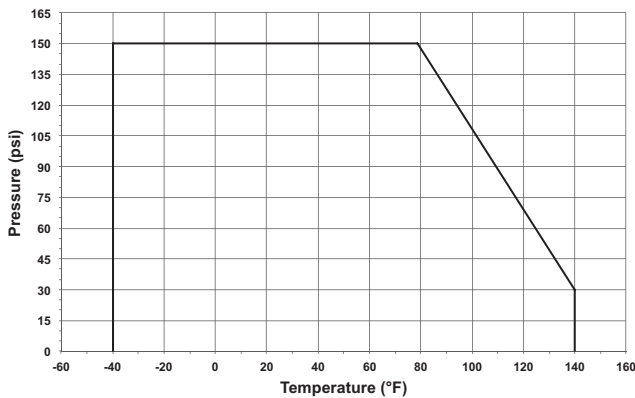

Flow

The following information is based on water applications at 68° F

Cv Value

Size (inch)	d (mm)	Cv (gal/min)
1/2	20	12.9
3/4	25	24.5
1	32	49.0
1 1/4	40	70.0
1 1/2	50	112.0
2	63	217.1

Dimensions

The following tables are shown in millimeters unless otherwise specified

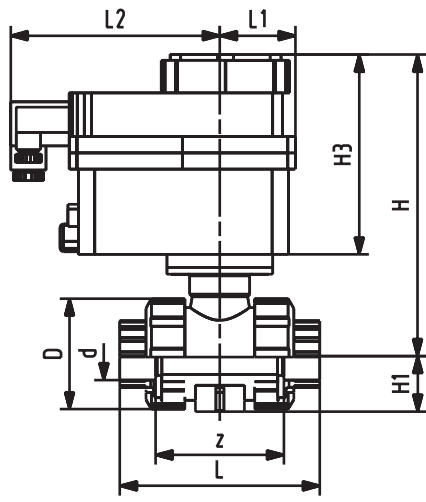

Socket/threaded

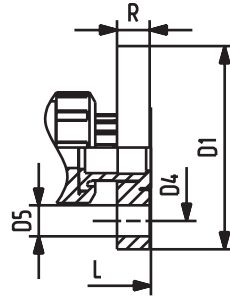

Flanged

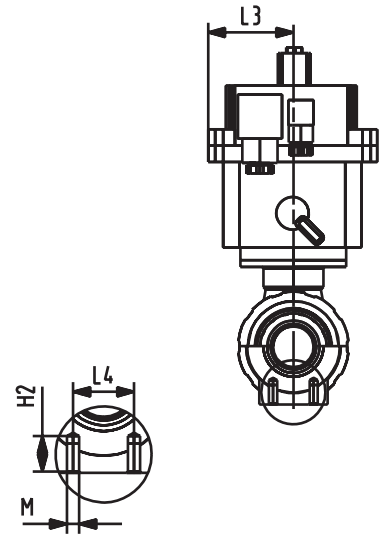

All Materials

All Materials

Size (inch)	D	H	H1	H2	H3	L1	L2	L3	L4	M
1/2	50	168	27	12	145	48	132	56	25	M6
3/4	58	173	30	12	145	48	132	56	25	M6
1	68	173	36	12	145	48	132	56	25	M6
1 1/4	84	177	44	15	145	48	132	56	45	M8
1 1/2	97	178	51	15	145	48	132	56	45	M8
2	124	184	64	15	145	48	132	56	45	M8

PVC/CPVC

Size (inch)	IPS Socket		Threaded NPT		ANSI Flanged				
	L	z	L	z	L	D1 (inch)	D4 (inch)	D5 (inch)	R (inch)
1/2	105	61	98	65	149	3.5	2.38	0.5	0.57
3/4	121	70	111	74	165	3.88	2.75	0.5	0.58
1	133	76	127	82	184	4.25	3.13	0.5	0.66
1 1/4	154	90	147	98	206	4.63	3.5	0.5	0.69
1 1/2	164	94	157	110	221	5	3.88	0.5	0.76
2	183	107	183	135	251	6	4.75	0.63	0.82

ABS

Metric Socket		
d (mm)	L	z
20	95	64
25	110	72
32	123	79
40	141	94
50	157	95
63	183	107