

Solenoid Valve Type 157



Product description

Type 157 is a high-quality, direct-acting 2/2-way pivoted armature solenoid valve that can be used for opening or closing. The magnetic system and the media chamber are separated from one another by a separating diaphragm system. The solenoid coils are moulded with a chemically resistant epoxy. The valve is especially suitable for aggressive media.

Function

A solenoid valve is a valve which is actuated by an electromagnet. Their tasks are to release, shut off, dose, distribute or mix gases and liquids. The solenoid valves can switch very fast, and guarantee high reliability and a long lifetime at a low actuator power. Solenoid valves with position measuring can be operated as servo valves.

Applications

- Water treatment
- Process/chemical engineering
- Plant/mechanical engineering
- Semiconductor industry
- Environmental engineering
- Medical engineering
- Apparatus engineering
- Analytical technology

Benefits/features

- PVC-U material: threaded socket with cylindrical female pipe thread Rp
- Circuit functions: A (normally closed - FC) and B (normally open - FO)
- Handle with ratchet setting
- Electrical connection with cable plug
- Protection rating IP65
- Service-friendly and robust manual override
- Direct-acting with isolating diaphragm
- Gasket materials are highly media-resistant
- Maintenance-free pivoted armature technology
- Vibration-proof, block screwed coil system

Flow media

Suited for aggressive media

Technical data

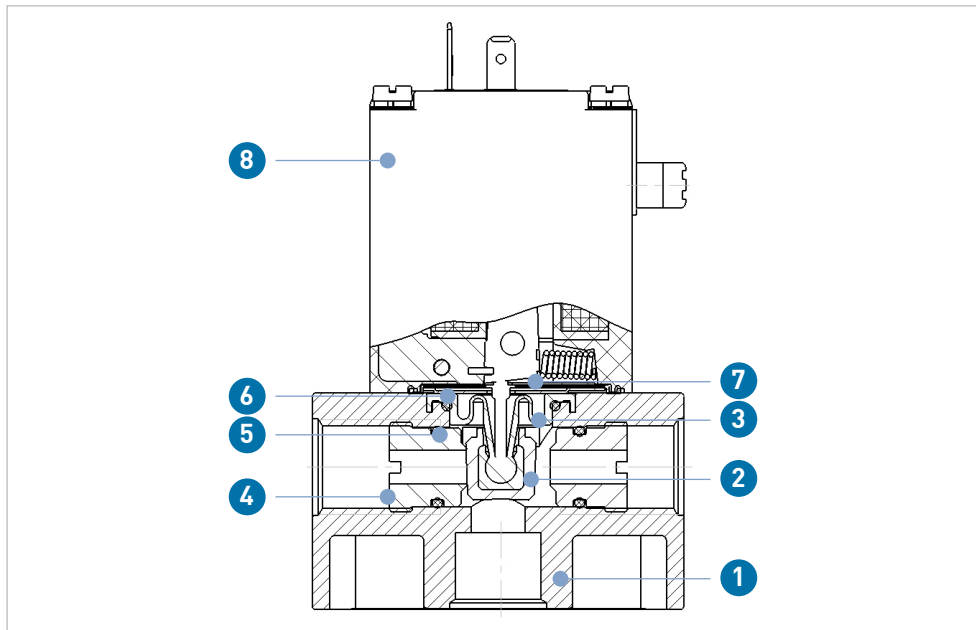

- ① PVC valve housing
- ② FKM gasket
- ③ PTFE rotating stem
- ④ PVC seat
- ⑤ FKM/EPDM O-Ring
- ⑥ PTFE gasket
- ⑦ FKM/EPDM isolating membrane
- ⑧ Epoxy coil

Specification		
Nominal diameter	DN2 – DN8	
Valve housing	PVC (resistant according to DIN 8062, 8061)	
Seal material media	FKM	Oxydizing acids and substances, hot oils with additives, salt solutions, waste gases
	EPDM	Alkalis, acids up to medium concentration, alkaline washing and bleaching lyes
Media temperatures	PVC + FKM	-10 to +50 °C
Housing + gasket (combination of materials)	PVC + EPDM	-30 to +50 °C
Ambient temperature	Max. +50 °C	
Viscosity	Max. 37 mm ² /s	
Voltage range	24V 50 Hz, 230V 50Hz, 24V UC*	
Voltage tolerance	±10%	
Switching frequency	Max. 100/min for AC	
	Max. 10/min for UC (high-capacity electronic)	
Rated duty	100 % ED for high-capacity electronic	
	40 % ED (10 min)	
Electrical connection with AC and DC	Plug in accordance with DIN EN 17301-803 Form A for cable plugs	
Protection rating	IP65 with cable plug	
Thermal insulation class of the coil	H	
Mounting position	As desired, preferably with actuator on top	
Weight	0.38 kg	

*UC = Universal Current = AC/DC

Flow rate, pressure range and electrical power consumption

Nominal dia- meter (mm)	Mechanism	Kv value ¹⁾ water (l/min)	Pressure range ²⁾		Power consumption Inrush (electrical)		Power consumption Operation(electrical)	
			AC (bar) ³⁾	DC (bar) ³⁾	AC (VA)	UC (W)	AC (VA/W)	UC (W)
4	A	5 ⁴⁾	0-4	0-2	30	40	15/8	8-12
6	A	10 ⁵⁾	0-2	0-1	30	40	15/8	8-12
8	A	16.7	0-1	0-0.8	30	40	15/8	8-12

¹⁾ Kv value (l/min) at +20 °C, 1 bar pressure at valve inlet and free outlet

²⁾ Pressure data (bar) excess pressure to atmospheric pressure

³⁾ Heat output 8W

⁴⁾ The Kv value is reduced to 4 l/min with sealing material FKM

⁵⁾ The Kv value is reduced to 8 l/min with sealing material FKM

Switching time

Frequency: AC		Frequency: UC	
Open (ms)	Close (ms)	Open (ms)	Close (ms)
20	11	11	8

Switching time (ms): Measurement at valve outlet at 6 bar and +20 °C. Open: Pressure build-up 0% to 90%. Close: Pressure build-up 100% to 10%.

Dimensions

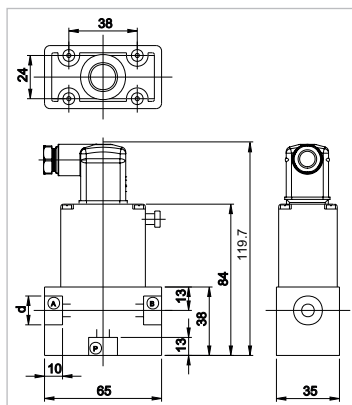

Housing material	Inch (inch)	B (mm)	E (mm)	F (mm)
PVC	G 3/8	91	35	65

Possible connections		
Mode of operation	Port 1	Port 2
A	A	P
B	P	B

i For further information on accessories, refer to the online product catalog at www.gfps.com

The information and technical data (altogether "Data") herein are not binding, unless explicitly confirmed in writing. The Data neither constitutes any expressed, implied or warranted characteristics, nor guaranteed properties or a guaranteed durability. All Data is subject to modification. The General Terms and Conditions of Sale of Georg Fischer Piping Systems apply.

10/2021-A
 © Georg Fischer Piping Systems Ltd, 8201 Schaffhausen/Switzerland
 Tel. +41 52 631 11 11 • www.gfps.com • E-Mail: info.ps@georgfischer.com