



Signet 2818-2823 Series Conductivity Sensor



3-2820.090-1 Rev. 16 08/19

Operating Instructions

2818 2819 2820 2821



2822 2823 Sanitary



- [English](#)
- [Deutsch](#)
- [Français](#)
- [Español](#)
- [中文](#)



Description

Signet 2818-2823 Conductivity/Resistivity Electrodes are designed to provide versatile installation and accurate sensing across a very broad dynamic range. These electrodes are built with a controlled surface finish to ensure accuracy and repeatability. The standard electrode is constructed 316 SS, but there are other materials available for maximum chemical compatibility (Titanium, Monel and hastelloy-C). Reversible threads or sanitary flanges allow for maximum installation versatility.

Sanitary flange versions are available in either SS or Titanium with quality surface finish of less than RA 25. An optional NIST Traceability Certificate (to meet USP requirements) is available. Coupled with GF Signet patented measuring circuitry, a platinum RTD (PT1000) located within the electrode allows optimal temperature sensing.

Features

- Standard process connections
 - 3/4" NPT Polypro
 - Tri-clamp 1 1/2", 2"
 - Opt. 1/2" NPT 316 SS
- 316 SS or Titanium standard electrode
- Alternative electrode materials available
 - Hastelloy-C
 - Monel
- In-line or submersible mounting
- NIST traceable certified cells ±1% meet USP requirements

Table of Contents

Warranty Statement.....	2
Product Registration.....	2
Chemical Compatibility.....	2
Safety Information.....	2
Dimensions.....	2
Specifications.....	3
Wiring.....	3
Recommended Position.....	3
In-Line Installation.....	4
2822 Submersible Installation.....	4
2823 Submersible Installation.....	4
Maintenance.....	4

Warranty Information

Refer to your local Georg Fischer Sales office for the most current warranty statement.

All warranty and non-warranty repairs being returned must include a fully completed Service Form and goods must be returned to your local GF Sales office or distributor. Product returned without a Service Form may not be warranty replaced or repaired.

Signet products with limited shelf-life (e.g. pH, ORP, chlorine electrodes, calibration solutions; e.g. pH buffers, turbidity standards or other solutions) are warranted out of box but not warranted against any damage, due to process or application failures (e.g. high temperature, chemical poisoning, dry-out) or mishandling (e.g. broken glass, damaged membrane, freezing and/or extreme temperatures).

Product Registration







Thank you for purchasing the Signet line of Georg Fischer measurement products.

If you would like to register your product(s), you can now register online in one of the following ways:

- Visit our website www.gfsignet.com and click on **Product Registration Form**
- If this is a pdf manual (digital copy), [click here](#)

Safety Information

1. Do not remove from pressurized lines.
2. Do not exceed max. temperature/pressure specifications.
3. Wear safety goggles or face shield during installation/service.
4. Do not alter product construction.
5. Disconnect instrument power before wiring this sensor.
6. Failure to follow safety instructions may result in severe personal injury!

	Warning / Caution / Danger Indicates a potential hazard. Failure to follow all warnings may lead to equipment damage, injury, or death
	Personal Protective Equipment (PPE) Always utilize the most appropriate PPE during installation and service of Signet products.
	Pressurized System Warning Sensor may be under pressure, take caution to vent system prior to installation or removal. Failure to do so may result in equipment damage and/or serious injury.
	Hand Tighten Only Overtightening may permanently damage product threads and lead to failure of the retaining nut.
	Do Not Use Tools Use of tool(s) may damage product beyond repair and potentially void product warranty.
	Note / Technical Notes Highlights additional information or detailed procedure.

Dimensions

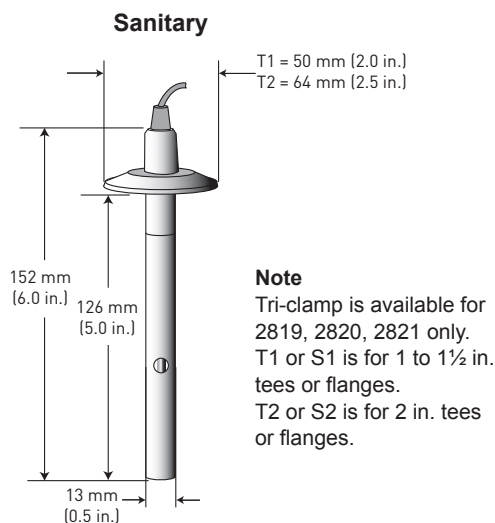
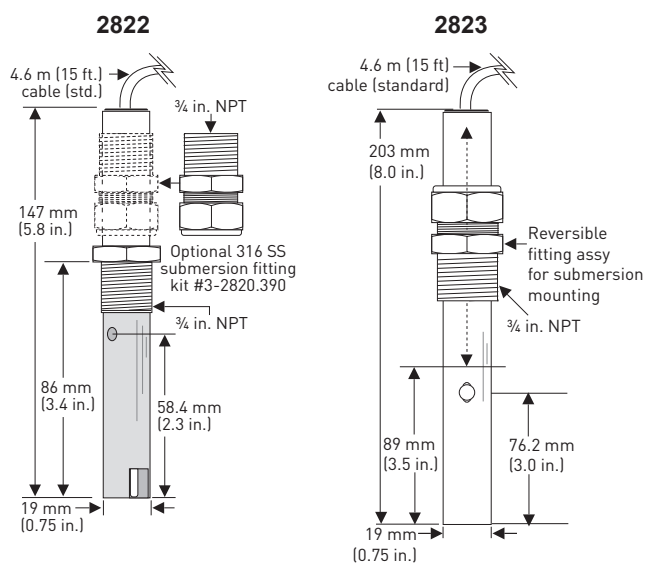
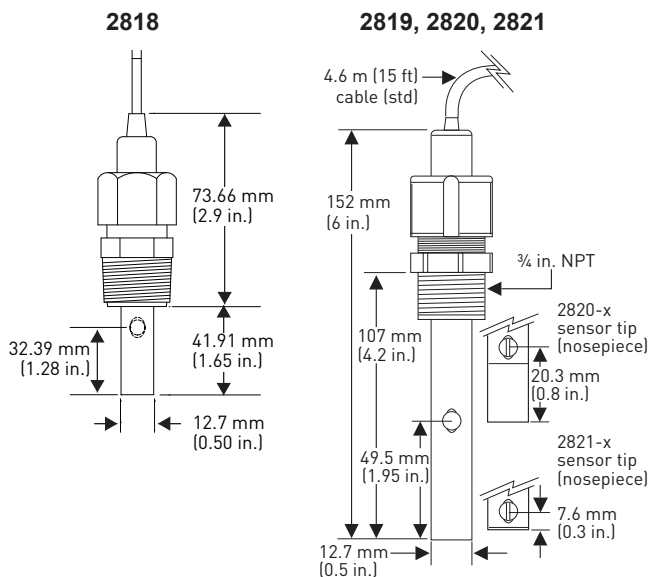

Specifications

General

Cell Constant

2818	0.01 cm ⁻¹
2819	0.01 cm ⁻¹
2820	0.1 cm ⁻¹
2821	1.0 cm ⁻¹
2822	10.0 cm ⁻¹
2823	20.0 cm ⁻¹

Operating Range:

2818	0.055 to 100 μS (10 kΩ to 18.2 MΩ)
2819	0.055 to 100 μS (10 kΩ to 18.2 MΩ)
2820	1 to 1000 μS (1 kΩ to 1 MΩ)
2821	10 to 10,000 μS (5 to 5000 ppm)
2822	100 to 200,000 μS (50 to 100,000 ppm)
2823	200 to 400,000 μS (100 to 200,000 ppm)

Cell Constant Accuracy ±2% (certified cells ±1%)

Temp. Compensation Device.. PT1000

Cable Length

Standard	4.6 m (15 ft)
Maximum	30 m (100 ft)
2818 & 2819-1	7.6 m (25 ft) max. when used with 8850 & 8860. Do Not splice cable.

Sanitary fitting size 1 in., 1½ in., 2 in.

Wetted Materials

O-Rings	EPR (EPDM)
Electrodes	316L Stainless Steel (1.4408, DIN 17440) or Titanium
Sanitary fitting	316L Stainless Steel or Titanium
2822 Body	CPVC
Insulator Material	
2818/2819/2820/2821	Carbon fiber reinforced PTFE
2823	PEEK®
Process Connection	¾ in. NPT threads; Standard 316 SS fitting & Optional 316 SS submersion adapter fitting (3-2820.390)

Shipping Weight

2818/2819/2820/2821/2822	0.4 kg (0.8 lb)
2823	0.3 kg (0.6 lb)

Environmental Requirements

Temperature Accuracy 0.3 °C

Max. Pressure/Temperature Ratings

2818/2819/2820/2821 Fittings:

Standard Polypropylene	6.9 bar @ 100 °C (100 psi @ 212 °F)
(3-2820.392) ½ NPT 316 SS	13.8 bar @ 120 °C (200 psi @ 248 °F)
Sanitary Connection	6.9 bar @ 120 °C (100 psi @ 248 °F)

2822 6.9 bar @ 95 °C (100 psi @ 203 °F)

2823 6.9 bar @ 150 °C (100 psi @ 302 °F)

Standards and Approvals

RoHS Compliant

 China RoHS (Go to www.gfsignet.com for details)

 Alternate wetted materials (such as Titanium, Hastelloy-C and Monel) are available through special order.

Cable length extensions to 30 m (100 ft.) are available through special order.

When using the ProcessPro 8850 or 8860: For resistivity measurements above 10 MΩ and/or below 20 °C, maximum cable length is 7.6 m (25 ft.).

Wiring

3-9900.092 Direct Conductivity/Resistivity Module

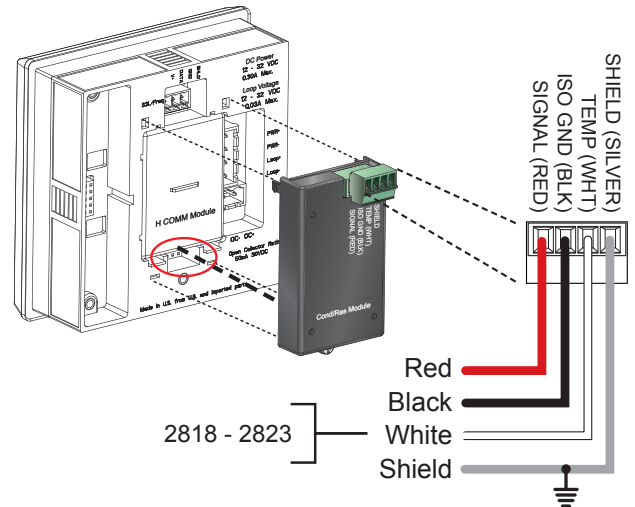

2850 Conductivity/Resistivity Sensor Electronics

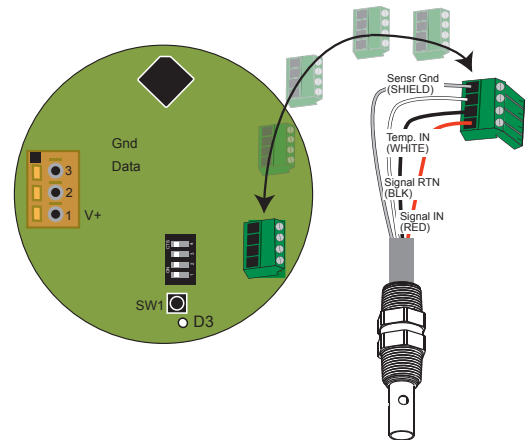

Recommended Position

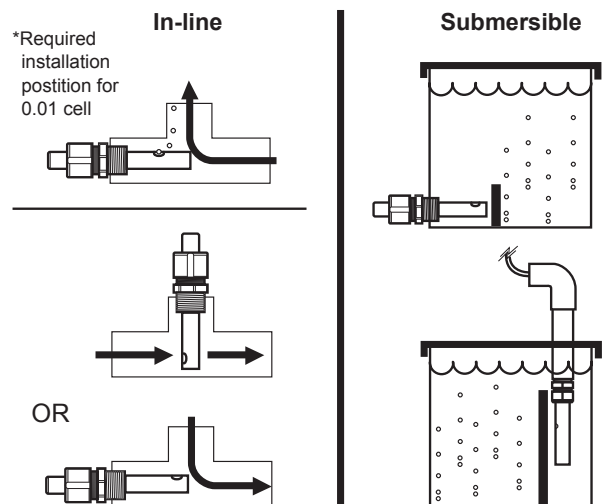

In-Line Installation



Installation tip:

Mark the sensor body to indicate the position of the vent hole. During installation, align the vent hole mark so it faces upward or against the process flow to prevent air bubble entrapment.

2818/2819/2820/2821

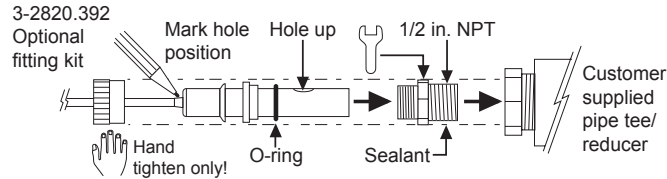
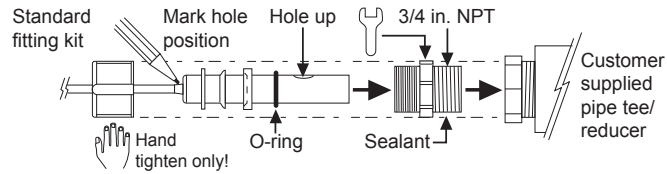

2822

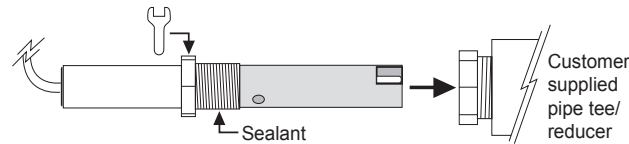

2823

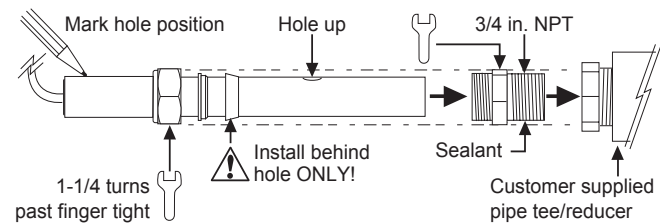

2822 Submersible Installation

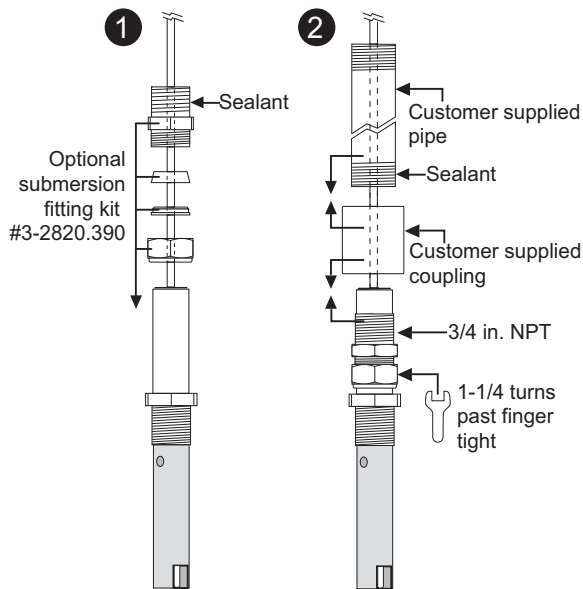

2823 Submersible Installation

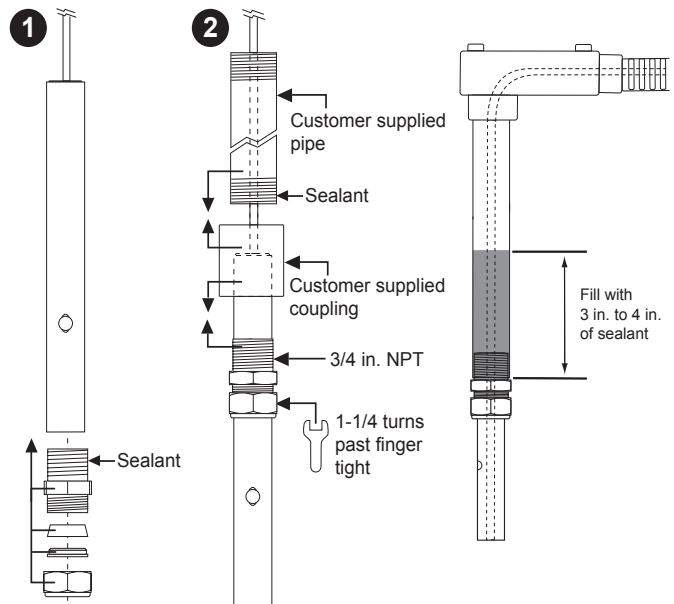

- Attach 3/4 in. watertight pipe to the top of the sensor.
- Secure the threaded connection to prevent any leakage.
- For additional defense against possible accumulation of condensation at the back seal area of the sensor, fill the lower 75 mm to 100 mm (3 in. to 4 in.) of conduit or extension pipe with a flexible sealant such as silicone.

Maintenance

- Any coatings on electrodes will cause readings to drift or show poor response.
- Clean metallic surfaces with a mild detergent and a non-abrasive brush or cotton swab.

2823-1 Sensor Tip Removal Procedure:

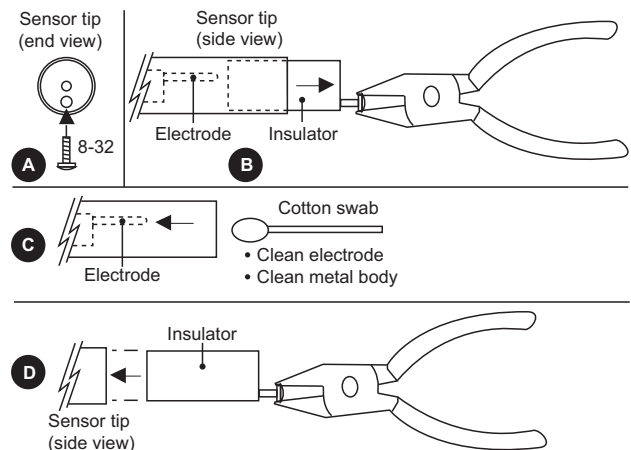

+GF+

Georg Fischer Signet LLC, 3401 Aero Jet Avenue, El Monte, CA 91731-2882 U.S.A. • Tel. (626) 571-2770 • Fax (626) 573-2057
 For Worldwide Sales and Service, visit our website: www.gfsignet.com • Or call (in the U.S.): (800) 854-4090
 For the most up-to-date information, please refer to our website at www.gfsignet.com