



# Signet 2580 FlowtraMag® Meter



3-2580.090 Rev 3 04/20

## Operating Instructions



- [English](#)
- [Deutsch](#)
- [Français](#)
- [Español](#)
- [中文](#)



### Description

The GF Signet 2580 FlowtraMag is a full-bore plastic PVC in line style magnetic flowmeter. The PVC body with titanium or *Hastelloy*® C electrodes has no moving parts, and is two to three times lighter in weight compared to traditional metal magmeters on the market. It is designed for high accuracy flow measurement in short pipe runs, making it an ideal solution for industrial applications where performance and ease of use are important.

The FlowtraMag is available in pipe sizes of DN25 (1 in.), DN50 (2 in.) and DN100 (4 in.), optimized for performance in short pipe runs often associated with final effluent lines, well heads and water treatment skids.

Features include:

- No moving parts
- No pressure drop
- Lighter in weight compared to traditional metal magmeters
- Reduced straight run requirements, ideal for final effluent lines, well heads and skids
- Factory calibrated with certificate ( $\pm 1\%$  of reading accuracy)
- Partially filled pipe detection status indicator
- Visual LED indicators make sensor status clear and easy to read
- Reverse flow direction configurable with 0252 Configuration Tool or GF Config Tool Bluetooth® App
- One device with three different outputs: field selectable Frequency or Digital (S<sup>3</sup>L), and analog 4 to 20 mA
- On-the-fly configuration with GF Config Tool Bluetooth® App
- Bluetooth® 4.2 capable, support iOS and Android for simple user configuration

### Table of Contents

|   |    |
|---|----|
| Warranty Information .....                          | 2  |
| Product Registration .....                          | 2  |
| Safety Information .....                            | 2  |
| Chemical Compatibility .....                        | 2  |
| Temperature-Pressure Graph .....                    | 2  |
| Specifications .....                                | 3  |
| Sensor Dimensions .....                             | 4  |
| Sensor Location .....                               | 5  |
| Sensor Mounting Angle .....                         | 5  |
| Sensor Pipe Installation .....                      | 6  |
| Wiring Configuration .....                          | 7  |
| Default Configurations .....                        | 8  |
| Wiring .....  | 9  |
| App Configuration - Setup .....                     | 12 |
| App Configuration - Monitor and Real Time Log ..... | 13 |
| App Configuration - Files .....                     | 14 |
| App Configuration - Sensor Setup .....              | 14 |
| Change Language .....                               | 16 |
| Calibration .....                                   | 16 |
| Customization and Performance Settings .....        | 16 |
| Averaging and Sensitivity Settings .....            | 17 |
| LED Status Indicators .....                         | 17 |
| Configuration - 0252 Configuration Tool .....       | 18 |
| Troubleshooting .....                               | 21 |
| Ordering Information .....                          | 24 |

U.S. and International Patents Pending



## Warranty Information

Refer to your local Georg Fischer Sales office for the most current warranty statement.

All warranty and non-warranty repairs being returned must include a fully completed Service Form and goods must be returned to your local GF Sales office or distributor. Product returned without a Service Form may not be warranty replaced or repaired.

Signet products with limited shelf-life (e.g. pH, ORP, chlorine electrodes, calibration solutions; e.g. pH buffers, turbidity standards or other solutions) are warranted out of box but not warranted against any damage, due to process or application failures (e.g. high temperature, chemical poisoning, dry-out) or mishandling (e.g. broken glass, damaged membrane, freezing and/or extreme temperatures).

## Product Registration

Thank you for purchasing the Signet line of Georg Fischer measurement products.

If you would like to register your product(s), you can now register online in one of the following ways:

- Visit our website [www.gfsignet.com](http://www.gfsignet.com). Under **Service and Support** click on **Product Registration Form**
- If this is a pdf manual (digital copy), [click here](#)

## Operating Pressure/Temperature Graph

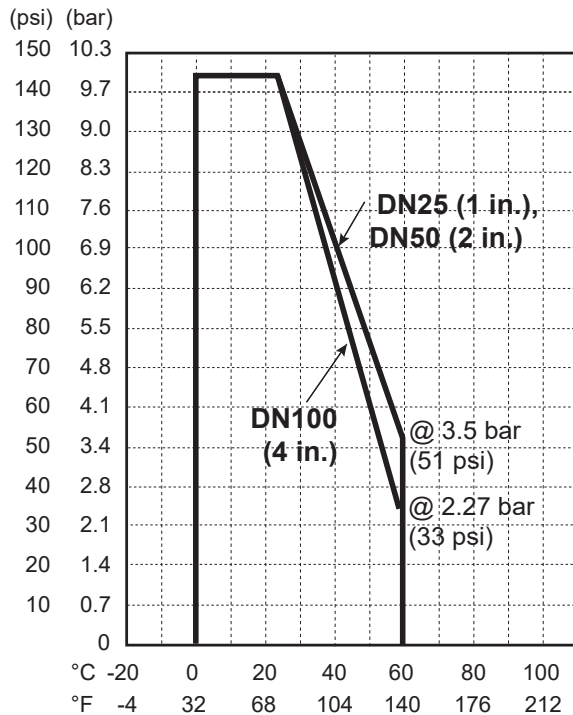

## Chemical Compatibility

Georg Fischer Signet products are manufactured in a variety of wetted materials to suit various liquids and chemicals.

All plastic materials including typical piping types (PVC) are more or less permeable to contained media, such as water or volatile substances, including some acids. This effect is not related to porosity, but purely a matter of gas diffusion through the plastic.

If the plastic material is compatible with the medium according to the application guidelines, the permeation will not damage the plastic itself. However, if the plastic encloses other sensitive components, as is the case with GF Signet FlowtraMag meter, these may be affected or damaged by the media diffusing through the plastic body.

**Unit is factory shipped configured to measure water.**

## Safety Information

1. Depressurize and vent system prior to installation or removal.
2. Confirm chemical compatibility before use.
3. DO NOT exceed maximum temperature or pressure specs.
4. ALWAYS wear safety goggles or face shield during installation and/or service.
5. DO NOT alter product construction.
6. If this equipment is used in a manner not specified by the manufacturer, the protection provided by the equipment may be impaired
7. **This device is not approved for use or installation in hazardous locations.**

|  |   |
|--|---|
|  | <b>Caution / Warning / Danger</b><br>Indicates a potential hazard. Failure to follow all warnings may lead to equipment damage, injury, or death  |
|  | <b>Electrocution Danger</b><br>Alerts user to risk of potential of injury or death via electrocution.   |
|  | <b>Electrostatic Discharge (ESD)</b><br>Alerts user to risk of potential damage to product by ESD..   |
|  | <b>Personal Protective Equipment (PPE)</b><br>Always utilize the most appropriate PPE during installation and service of Signet products.   |
|  | <b>Pressurized System Warning</b><br>Sensor may be under pressure, take caution to vent system prior to installation or removal. Failure to do so may result in equipment damage and/or serious injury. |
|  | <b>Hand Tighten Only</b><br>Overtightening may permanently damage product threads and lead to failure. (union nut only)   |
|  | <b>Do Not Use Tools</b><br>Use of tool(s) may damage product beyond repair and potentially void product warranty. (union nut only)  |
|  | <b>Note / Technical Notes</b><br>Highlights additional information or detailed procedure.   |

## Specifications

### General

|   |   |
|---|---|
| Pipe Size Range .....                                       | DN25 (1 in.), DN50 (2 in.)<br>DN100 (4 in.)                                       |
| Flow Range - Titanium or <i>Hastelloy C</i>                 |   |
| Minimum.....  | 0.02 m/s (0.07 ft/s)  |
| Maximum.....  | 10 m/s (33 ft/s)  |
| DN25 (1 in.) .....  | 0.53 to 266.35 L/min<br>(0.14 to 70.36 gal/min)                                   |
| DN50 (2 in.).....   | 2.23 to 1112.60 L/min<br>(0.59 to 293.92 gal/min)                                 |
| DN100 (4 in.).....  | 8.72 to 4357.83 L/min<br>(2.30 to 1151.22 gal/min)                                |
| Repeatability .....   | ± 0.5% of reading @ 25 °C (77 °F)   |
| Accuracy .....  | ± 1% ± 0.01 m/s (0.033 ft/s)<br>(reference condition 50 µS/cm and<br>water based) |
| Minimum Conductivity.....                                   | 20 µS/cm - water based  |
| Suspended Solids .....                                      | 5%  |
| Power Cable Wire .....                                      | 7.6 m (25 ft) 2-conductor shielded  |
| Output Cable Wire .....                                     | 7.6 m (25 ft) 5-conductor shielded  |
| • May be extended up to 305 m (1000 ft), special order only |   |

### Wetted Materials

|                      |  |
|----------------------|--|
| Flow Tube Body ..... | PVC  |
| Electrode .....      | Titanium, grade 2 or<br><i>Hastelloy C-276</i> |
| O-rings.....         | FKM  |

### Electrical

|  |                                |
|--|--------------------------------|
| Power Requirements   |                                |
| DC Power   |                                |
| (Functional Rating).....   | 24 VDC, max 24W (12 to 32 VDC) |
| Reverse Polarity Protected .....   | Up to 35 VDC                   |
| Over-Voltage Max. Rating.....  | 35 VDC                         |
| Please use a power supply that has been IEC 60950/61010/60601<br>Certified and will not be used outside of its electrical ratings and<br>matches the environmental conditions of the flow meter. |                                |

### Current Output

|  |                          |
|--|--------------------------|
| Passive (low power) 4 to 20 mA per ANSI-ISA 50.00.01 class H |                          |
| Active Output.....   | 4 to 20 mA               |
| Passive Loop Voltage .....                                   | 12 to 32 VDC             |
| Loop Accuracy.....   | ± 32 µA (25 °C @ 24 VDC) |
| Loop Resolution .....  | 5 µA                     |
| Loop Span.....   | 3.8 mA to 21 mA          |
| Error condition.....   | None, 3.6 mA or 22 mA    |
| Max. Cable .....   | 300 m (1000 ft)          |
| Max. Loop Resistance .....                                   | 600 Ω @ 24 VDC           |
| Compatible with PLC, PC or similar equipment                 |                          |

### Frequency Output

|  |                                 |
|--|---------------------------------|
| Frequency .....  | 5 to 24 VDC, 50 mA max.         |
| Frequency Range .....  | 0 to 1500 Hz                    |
| Max. Pull-up Voltage .....   | 30 VDC, 10k pull-up recommended |
| Max. Cable .....   | 300 m (1000 ft)                 |
| Compatible with Signet 8900, 9900, 9950, and<br>0486 Profibus Concentrator |                                 |

### Digital (S<sup>3</sup>L) Output

|   |                       |
|---|-----------------------|
| Digital (S <sup>3</sup> L) .....  | 4.5 to 5.5 VDC        |
| Serial ASCII, TTL level 9600 bps  |                       |
| Compatible with Signet 8900, 9900, 9950 and<br>0486 Profibus Concentrator |                       |
| Max. Cable Length.....  | Application dependent |

*Hastelloy*® is a registered trademark of Haynes International.

### Sensor Configuration

|   |  |
|---|--|
| GF Config Tool Bluetooth® App                                 |  |
| 2.4 GHz RF Transceiver Compatible with Bluetooth®             |  |
| Low Energy (BLE) 4.2 Specification                            |  |
| GF Config Tool App available in iOS and Android<br>App Stores |  |

0252 Configuration Tool

### Environmental Requirements

|                                 |                                    |
|---------------------------------|------------------------------------|
| Enclosure .....                 | NEMA 4X / IP65                     |
| Relative Humidity .....         | 0 to 95% (non-condensing)          |
| Altitude .....                  | 4,000 m (13,123 ft)                |
| Storage Temperature .....       | -10 °C to 60 °C (14 °F to 140 °F)  |
| Operating Temperature           |                                    |
| Ambient .....                   | -10 °C to 60 °C (14 °F to 140 °F)  |
| Media .....                     | 0 °C to 60 °C (32 °F to 140 °F)    |
| UL environmental Rating.....    | UL 50, Type 6P Storage             |
| Maximum Operating               |                                    |
| Pressure.....                   | 10 bar @ 23 °C (145 psi @ 73 °F)   |
| DN25 (1in.) and DN50 (2in.).... | 3.5 bar @ 60 °C (51 psi @ 140 °F)  |
| DN100 (4in.).....               | 2.27 bar @ 60 °C (33 psi @ 140 °F) |

### Shipping Weights - Titanium or *Hastelloy C*

|                    |                   |
|--------------------|-------------------|
| DN25 (1 in.).....  | 3.4 kg (7.5 lbs)  |
| DN50 (2 in.).....  | 4.5 kg (9.9 lbs)  |
| DN100 (4 in.)..... | 8.3 kg (18.3 lbs) |

### Sensor Weights - Titanium or *Hastelloy C*

|                    |  |
|--------------------|--|
| DN25 (1 in.).....  | 2.7 kg (5.9 lbs)                                     |
| DN50 (2 in.).....  | 3.7 kg (8.1 lbs)                                     |
| DN100 (4 in.)..... | 6.26 kg (13.9 lbs) - (excludes mounting<br>hardware) |

### Standards and Approvals

|   |  |
|---|--|
| CE  |  |
| UL, CUL Recognized Component  |  |
| NSF (Titanium only, does not include Flange gaskets)  |  |
| RoHS compliant  |  |
| Manufactured under ISO 9001 for Quality, ISO 14001<br>for Environmental Management and OHSAS 18001 for<br>Occupational Health and Safety. |  |
| China RoHS (visit <a href="http://gfsignet.com">gfsignet.com</a> for details)   |  |

### FC Declaration of Conformity according to FCC Part 15

This device complies with Part 15 of the FCC rules.  
Operation is subject to the following two conditions:  
(1) This device may not cause harmful interference, and,  
(2) This device must accept any interference received, including  
interference that may cause undesired operation.



The Bluetooth® word mark and logos are registered trademarks owned by Bluetooth SIG, Inc. and any use of such marks by Georg Fischer is under license. Other trademarks and trade names are those of their respective owners.

# Sensor Dimensions



## WARNING!

ASTM and Metric pipe cutout dimensions are different.

### 1 in.

Union ends and union nuts shown

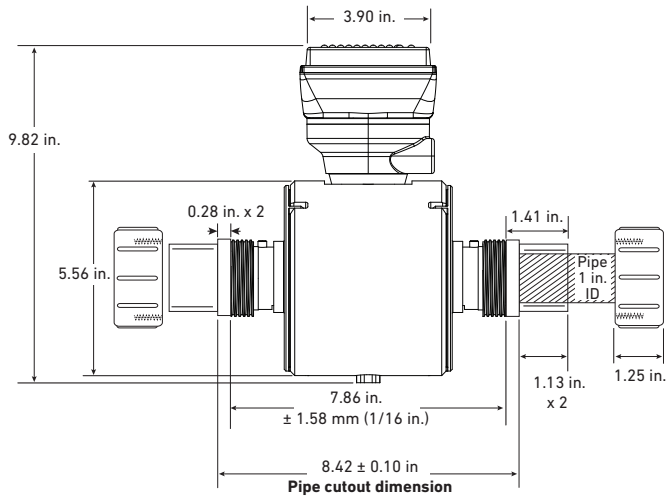

### DN25

Union ends and union nuts shown

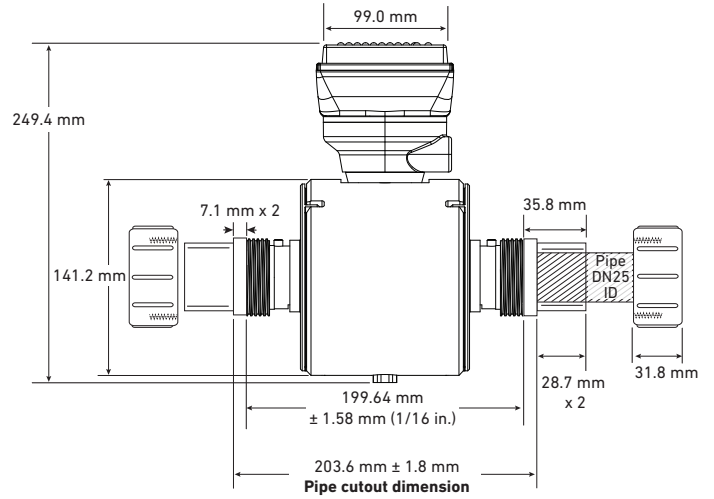

### 2 in.

Union ends and union nuts shown

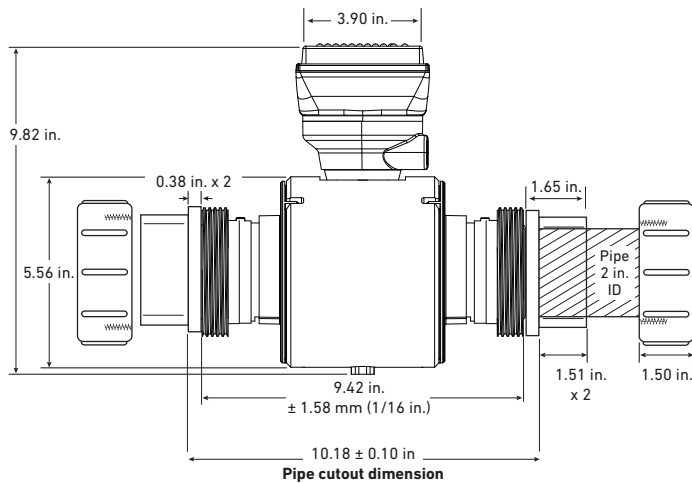

### DN50

Union ends and union nuts shown

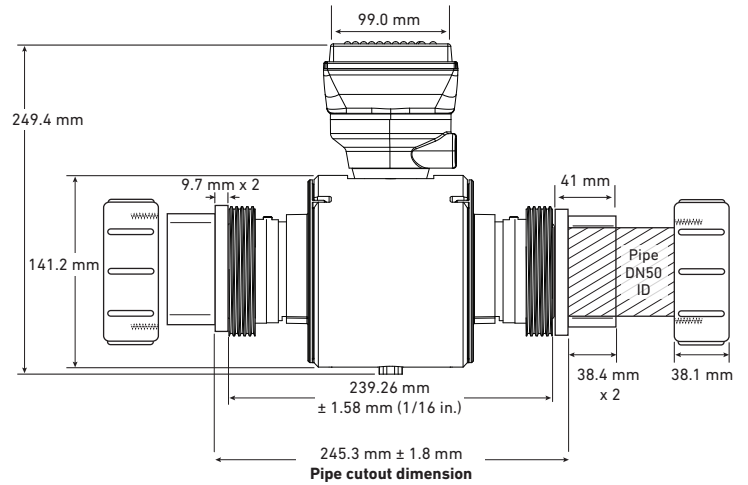

### 4 in.

Flange bolt kits and gaskets not shown (Sold separately)

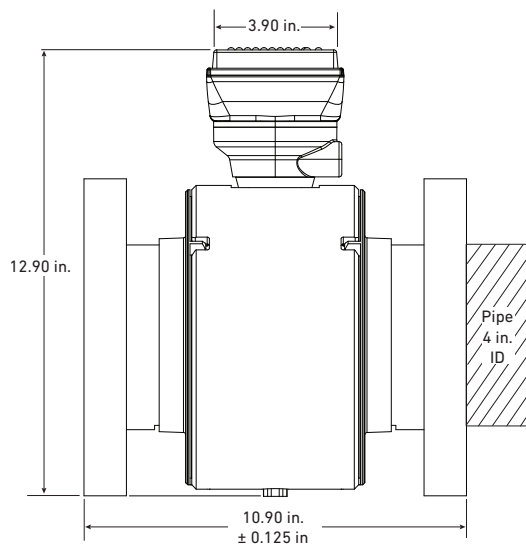

### DN100

Flange bolt kits and gaskets not shown (Sold separately)

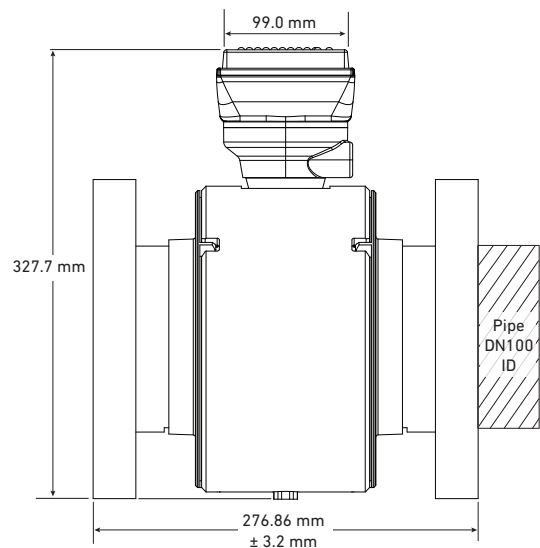

## Sensor Location

The 2580 FlowtraMag requires a minimum of 3x ID upstream and 2 x ID downstream of the sensor for best performance.

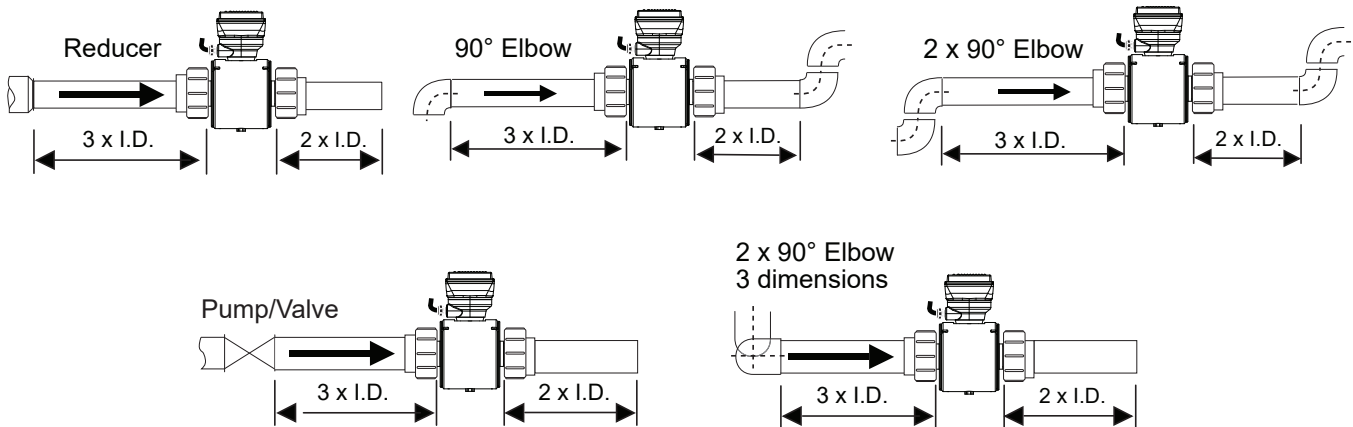

## Sensor Mounting Angle

### Horizontal Pipe Runs

GF recommends installing the sensor electronics at the 12 o'clock position.



#### **DO NOT HANDLE BY THE SENSOR!**

Always handle FlowtraMag Meters by the union nuts or flanges, **NOT** the sensor head.

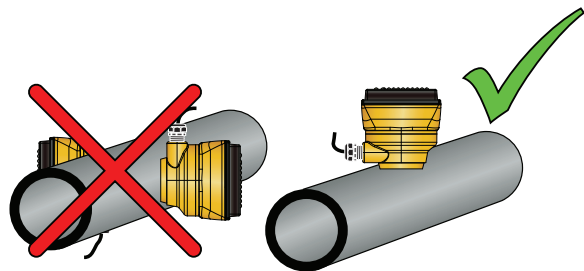

### Vertical Pipe Runs

To ensure pipe is flowing full with some back pressure, it is highly recommended that the fluid flows upward.

### Gravity and Discharge Lines

It is recommended to install a u-trap to ensure the pipe remains full at all times, and to minimize air bubbles. A vacuum breaker may be required downstream of the FlowtraMag to ensure pipe doesn't drain and fill with air.

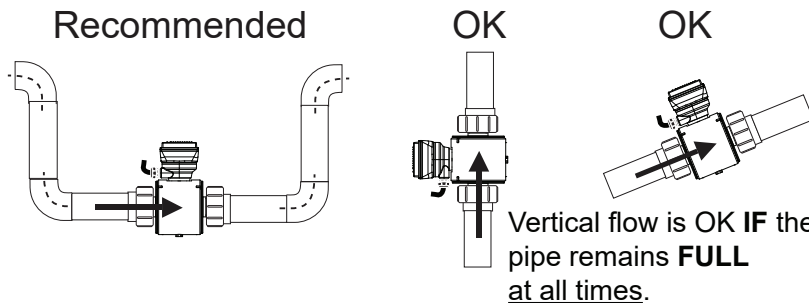

## Sensor Pipe Installation

1. Choose a mounting location that satisfies the requirements.
2. Select appropriate (Metric or ASTM) union end for installation
3. Install sensor with flow arrow pointing in the direction of flow.

**Note:** Gland fittings should point upstream of flow.



**Application Tip:** For Metric pipe installation, change union end to Metric.



**2580 FlowtraMag DN25 (1 in.)  
2580 FlowtraMag DN50 (2 in.)  
Union Ends**

**Hand Tighten Only!**

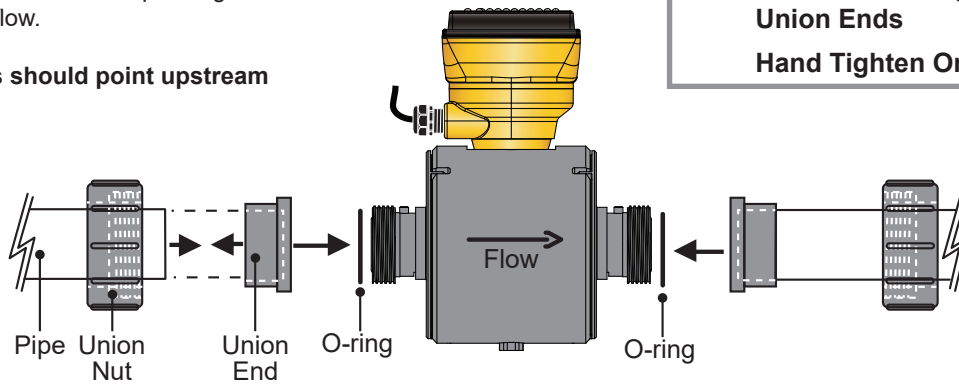

**2580 FlowtraMag DN100 (4 in.) Bolts  
DO NOT OVER TORQUE!**

Recommended bolt torque for the DN100 (4") flange of 27-41 Nm, (20 to 30 ft-lbs)

Tighten bolts by first assembling and hand tightening the nuts to position the gasket in place. Then tighten the bolts in a diagonal pattern 50% the recommended torque, then 100% of recommended torque.

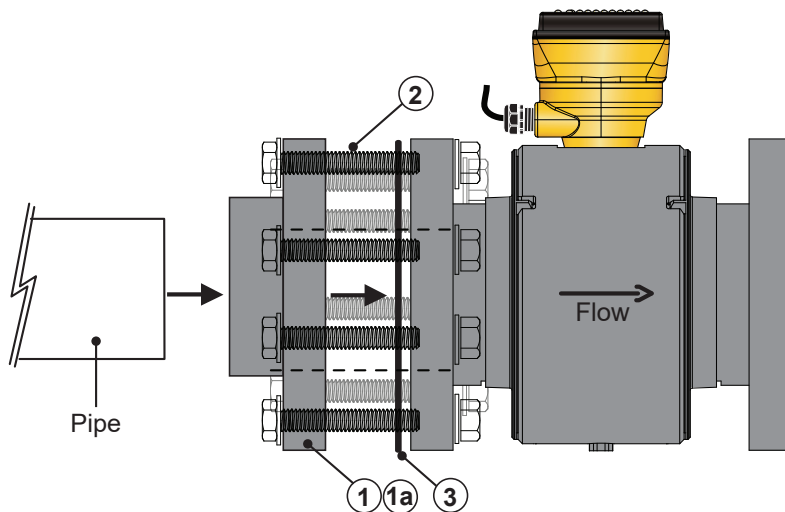
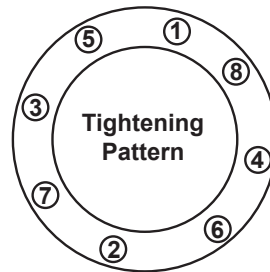

| Part No.     | Description   |
|--------------|---|
| ① 854-040    | DN100 Flange Adapter, PVC-U Metric                              |
| ①a 721790114 | DN100 Flange Adapter, PVC-U Metric (with backing flange, below) |
| 721700014    | DN100 Backing Flange, PVC-U Metric                              |
| ② 37Z000069  | Van Stone Flange Bolt Kit, 8 hole                               |
| ③ 749440714  | DN100 Profile Gaskets   |

Sold separately, quantity 2 required. See Ordering Information.

## Wiring Configuration

When using the 2580 FlowtraMag with frequency or Digital (S<sup>3</sup>L), all of the connections from the 2580 FlowtraMag to external equipment (PLC, Datalogger, Chart Recorder, Flow meter, etc.) are made using the red and white wires. See wiring diagrams for further details.

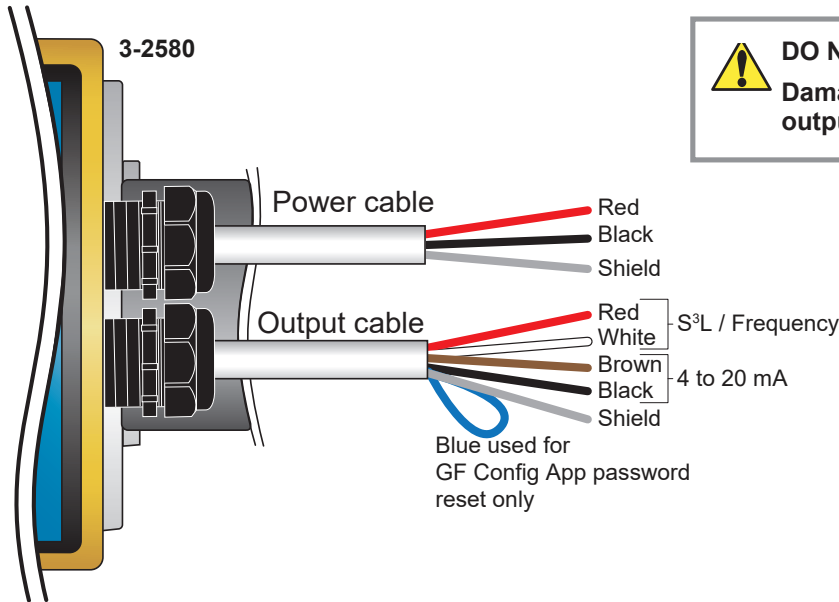

### Electromagnetic Compatibility (EMC) Recommendations

Complex instrumentation systems such as the 2580 FlowtraMag and the associated devices may face challenges involving Electromagnetic Interference (EMI). EMI interference may be coupled to the system via cables (conducted interference) or broadcast via electrical radiation (radiated interference).

Radiated interference may be mitigated by relocating the source or increasing the distance from the source. Metal shielding may be used.

Conducted interference can be mitigated by careful wiring practices. Because EMI may follow multiple paths, it will be necessary to observe the effectiveness of various grounding options.

#### 2580 FlowtraMag Power Cable

- In electrically noisy environments, connect the power cable shield (drain) wire to a clean low impedance earth ground.
- If there is a single power supply for all 2580 FlowtraMag system components (Instruments, PLCs and VFDs), route signal wiring directly to the instruments. Do not use ground points common to other wiring. Avoid creating ground loops.
- If separate power supplies are used, connect all power grounds to a common low impedance ground.

#### 2580 FlowtraMag Output Cable

- In electrically noisy environments, connecting the Signal Output cable shield (drain) wire to a clean low impedance earth ground may help reduce signal noise and preserve communication. Observe the difference between connecting or not connecting the shield. Avoid creating ground loops.

##### Frequency/S<sup>3</sup>L Output

- The S<sup>3</sup>L/Frequency cable shares the ground with the 2580 FlowtraMag Power Supply. Use a common DC power supply for the 2580 FlowtraMag and the flow instrument.

##### 4 to 20 mA Output

- If the 4 to 20 mA is used to control a highly inductive load such as a Variable Freq Drive or a DC motor, use separate DC power supplies for the 2580 FlowtraMag and the 4 to 20 mA device, active mode should be used.
- In Passive mode the 2580 FlowtraMag loop output cable shares the ground with the 2580 FlowtraMag Power Supply. Use the same DC power supply for the 2580 FlowtraMag and the 4 to 20 mA device.
- In Active mode the 2580 FlowtraMag loop output cable is isolated from the 2580 FlowtraMag Power Supply. The 4 to 20 mA device can use a different Power Supply.

## Wiring Configuration Continued



### Recommended:

The directional arrow should be pointed **DOWNSTREAM** for correct operation. If the 2580 FlowtraMag is installed on a vertical pipe, the cable ports should be turned to point downward. This will prevent condensation from being channeled into the enclosure.

### Application Tip:

If your flow is in the reverse direction, it is possible to set up reverse flow via the GF Signet 0252 Configuration Tool or GF Config Tool  Bluetooth® App.



## Default Configurations

|                          | DN25 (1 in.)      | DN50 (2 in.)      | DN100 (4 in.)     |
|--------------------------|-------------------|-------------------|-------------------|
| <b>Units</b>             | GPM               | GPM               | GPM               |
| <b>Totalizer Units</b>   | Gallons           | Gallons           | Gallons           |
| <b>Temperature Units</b> | °C                | °C                | °C                |
| <b>K-Factor Values</b>   | 852.716 pulse/gal | 204.139 pulse/gal | 52.1188 pulse/gal |
| <b>Averaging</b>         | Low               | Low               | Low               |
| <b>Sensitivity</b>       | 3.5182            | 14.696            | 57.561            |
| <b>Low Flow Cutoff</b>   | 0.1407            | 0.5878            | 2.3024            |
| <b>4 mA Setpoint</b>     | 0                 | 0                 | 0                 |
| <b>20 mA Setpoint</b>    | 70.363            | 293.92            | 1151.2            |
| <b>Error Current</b>     | 22                | 22                | 22                |
| <b>Passive/Active</b>    | Passive           | Passive           | Passive           |
| <b>S3L/Freq</b>          | Freq              | Freq              | Freq              |

### NOTE:

Temperature Units on Bluetooth® app will not be available for *Hastelloy C*. (Function will display: nan °C.)

## Wiring

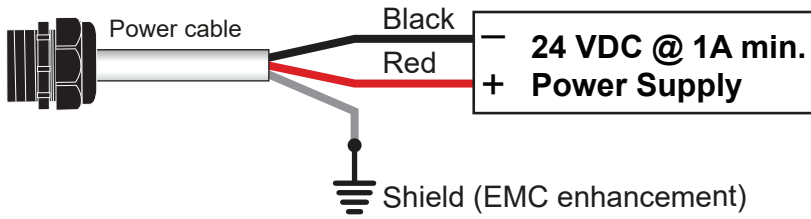

**CAUTION!**  
Turn off Power before Wiring.



**DO NOT REMOVE Seal!**  
Warranty void if seal is broken or removed.

**WARRANTY VOID IF REMOVED**

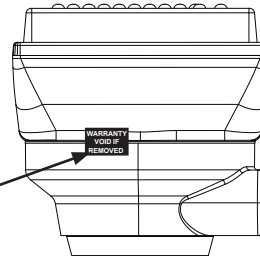

## Wiring with 4 to 20 mA Loop Output

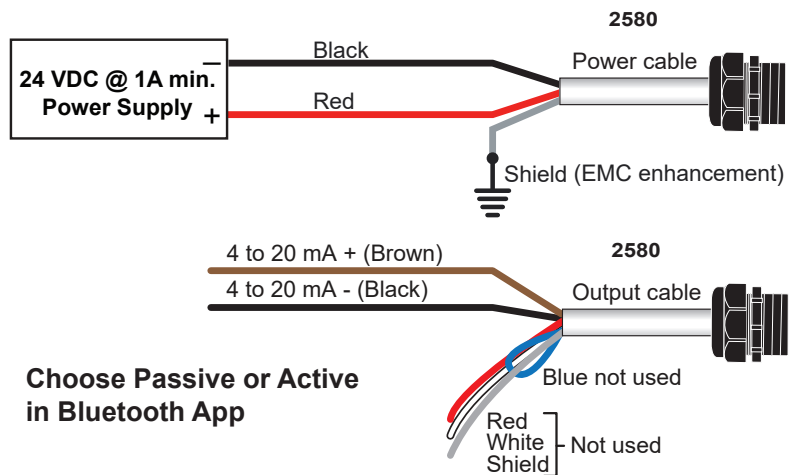

## Wiring with Frequency Output

### Compatible with all POWERED Signet Flow Instruments

- When choosing **Frequency** in the Bluetooth® App, the 2580 FlowtraMag outputs an open collector frequency signal that can be connected to any powered Signet flow meter (models 8900, 9900, 9900-1BC, 9950).
- 24 VDC power at 1 amp should always be connected.

**NOTE:** The frequency output will be displayed as positive flow regardless of the flow direction.

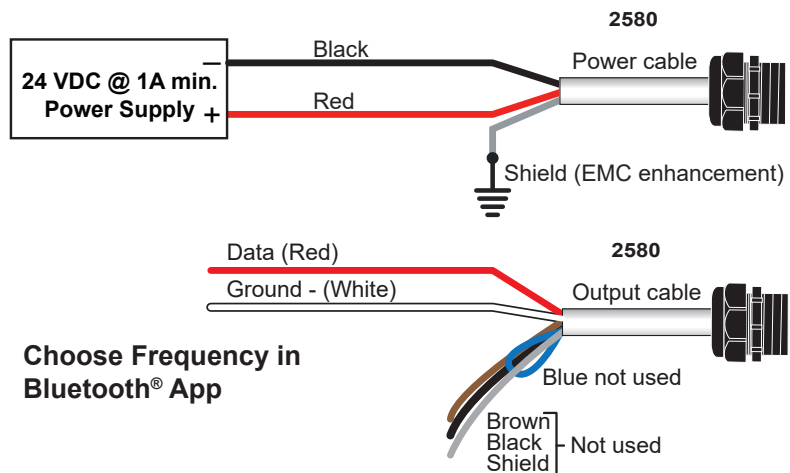

## Wiring with Frequency Other Manufacturer's Equipment

When using the 2580 FlowtraMag in a system with other manufacturer's equipment, a 10 KΩ pull-up resistor (not supplied) may be required to power the open collector output.

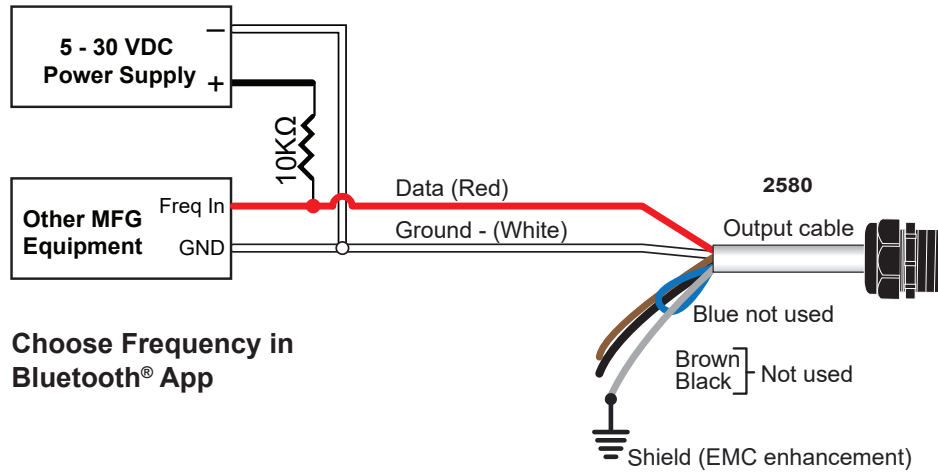

Choose Frequency in Bluetooth® App

## Wiring with Digital (S<sup>3</sup>L) Output

2580 FlowtraMag Wiring to Signet 8900 - Two digital (S<sup>3</sup>L) inputs

8900

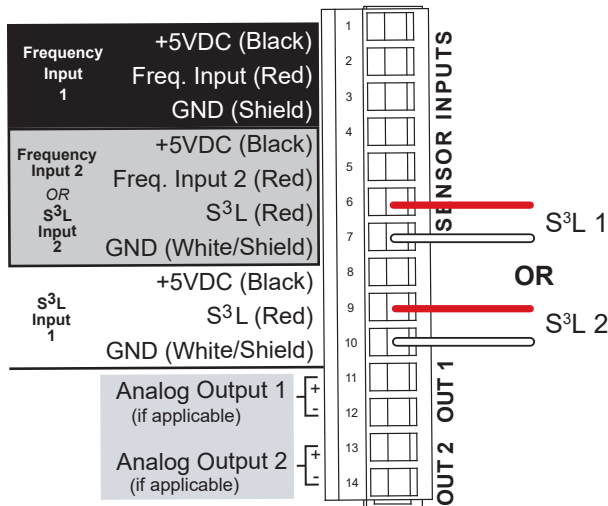

GF Config Tool App set to S<sup>3</sup>L

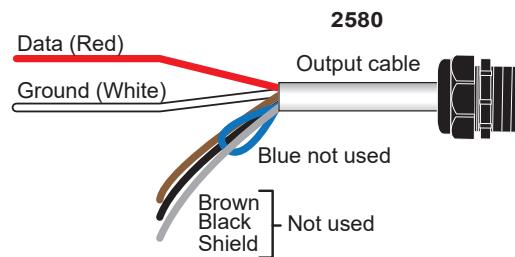

2580 FlowtraMag Wiring to Signet 8900 - One digital (S<sup>3</sup>L) input and one Frequency input

8900

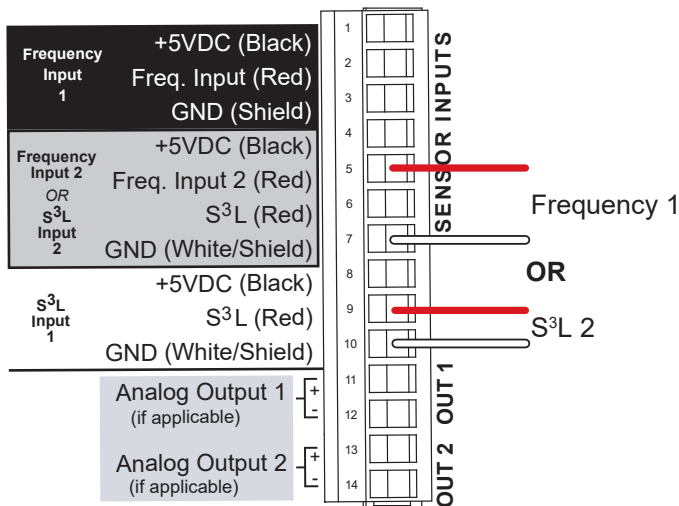

GF Config Tool App set to S<sup>3</sup>L on Channel 2

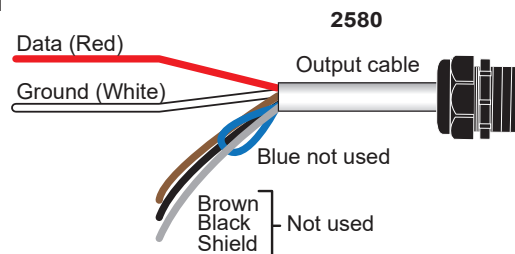

## Wiring with Digital (S<sup>3</sup>L) Output

### Digital (S<sup>3</sup>L) Output (Compatible with 8900 Multi-Parameter Controller, 9900 and 9950 Transmitter)

- To select S<sup>3</sup>L, use Bluetooth® App.
- 24 VDC power at a minimum of 1 amp is always be connected to the 2580 FlowtraMag.
- The 8900 will display 0 (Zero) flow rate during periods of reverse flow.**  
**The 9900 and 9950 will display negative numbers to indicate reverse flow.**
- The maximum cable length from the 2580 FlowtraMag to the 8900 or 9900 depends on the 8900 or 9900 configuration. Refer to the 8900, 9900 or 9950 manual for complete information.

#### 2580 FlowtraMag Wiring to Signet 9900

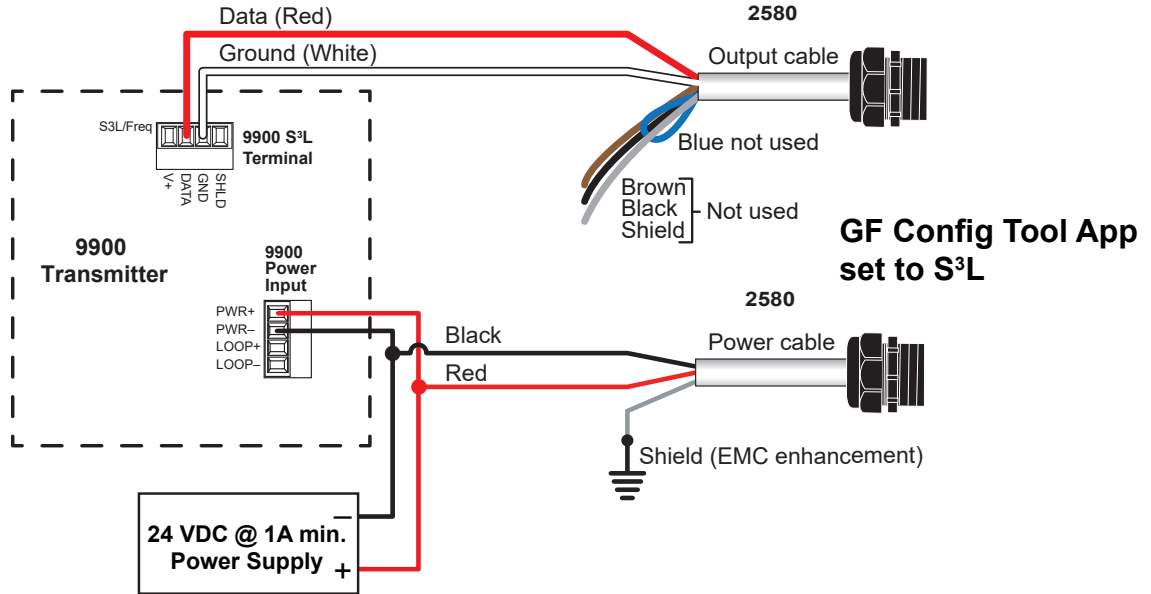

#### 2580 FlowtraMag Wiring to Signet 9950

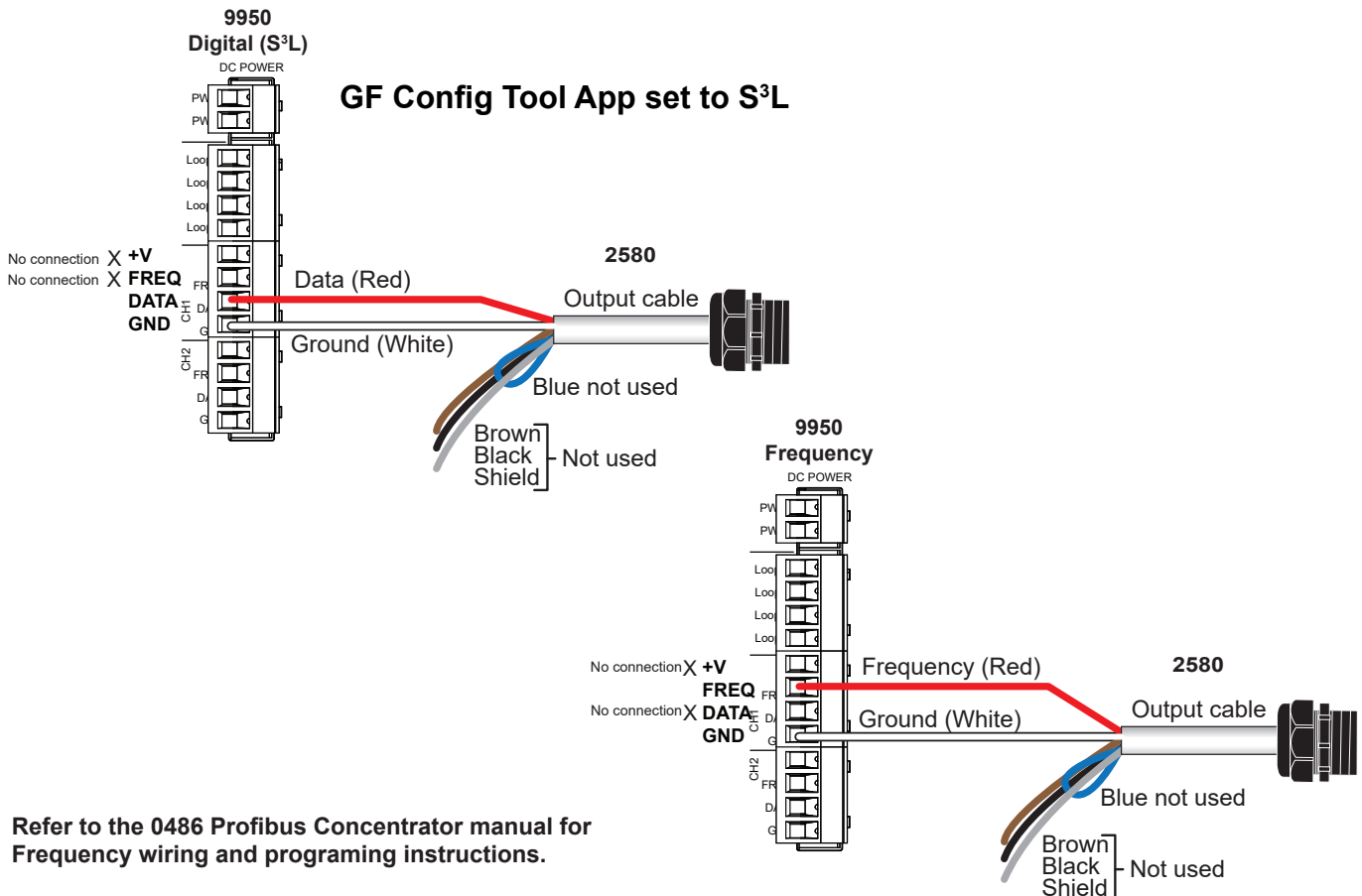

Refer to the 0486 Profibus Concentrator manual for Frequency wiring and programming instructions.

## App Configuration - App Set Up

### Bluetooth® App Setup Steps - iOS version

Search for **GF Configuration Tool** in the App store. Download the **GF Config Tool**.

1. Press **GET**. App will install on phone or other wireless device.
2. Return to home screen and look for App icon, click the blue **GF Config Tool** icon
3. Continue to Sensor Setup Section (next page)

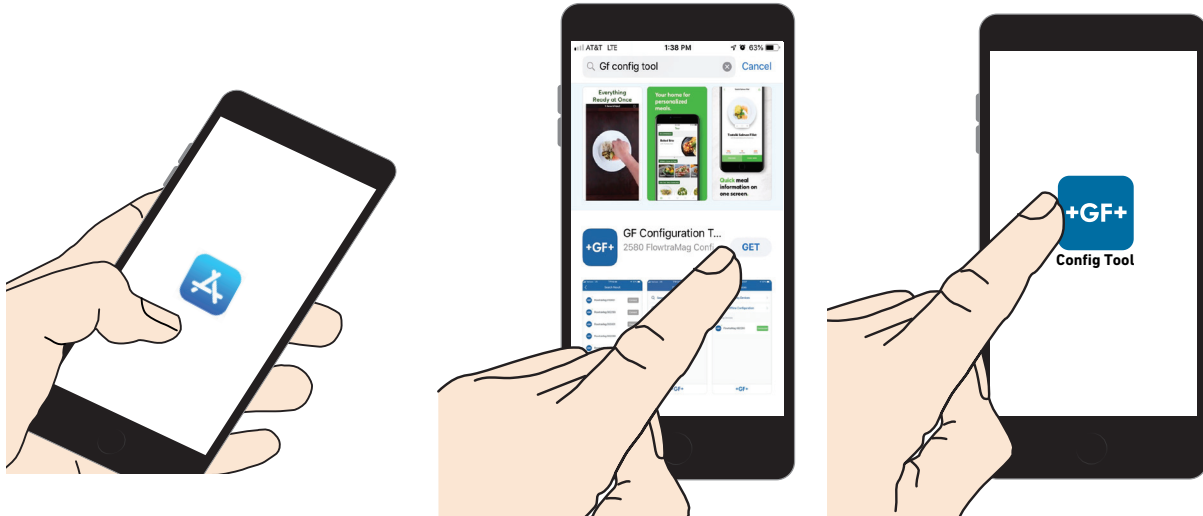

### Bluetooth® App Setup Steps - Android version

Download the **GF Configuration Tool** App by scanning the QR code or searching in Google Play directly.

1. When prompted press **Install**
2. Return to home screen and look for App icon, click the blue **GF Config Tool** icon
3. Continue to Sensor Setup section (next page.)



## App Configuration - Sensor Setup

When the 2580 FlowtraMag is in operation, when in close proximity to the 2580 FlowtraMag (less than 20 ft), open the **GF Config Tool App** to begin a search nearby devices and go thru the pairing process. Click on connect next to device you are pairing to.

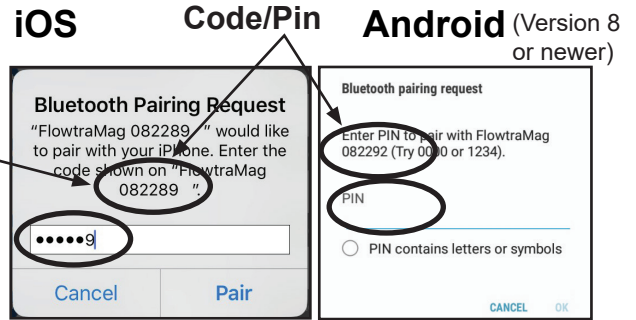
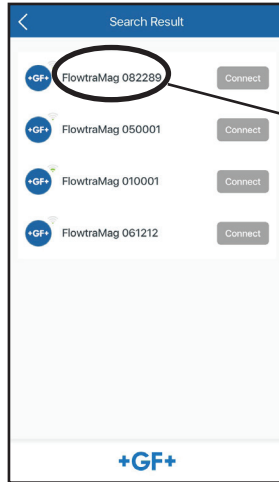

1. Pair the device by entering the device Code/Pin.  
The default Passkey is the last 6 digits of the product serial number.
2. Click **Pair/OK**
3. Make any adjustments to the 2580 FlowtraMag, if necessary, by tapping the Hamburger Menu (menu list) or Gear (edit settings).



**Note:**

If the GF Config Tool password has been lost or forgotten, connect blue wire to white wire while unit is powered (for 2 to 5 seconds.) Password will reset to factory original (last 6 digits of serial number.)



(example shows Menu)

## App Configuration - Monitor and Real Time Log

Monitoring flow and temperature

Real Time Log while connected to mobile / tablet device, set 1 sec or more increments

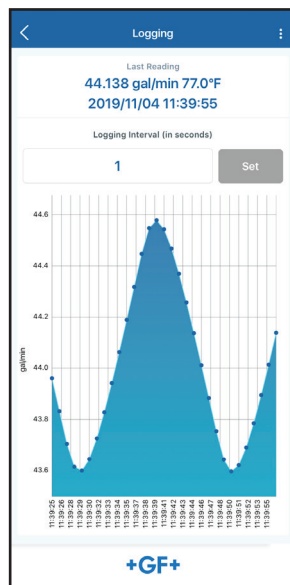
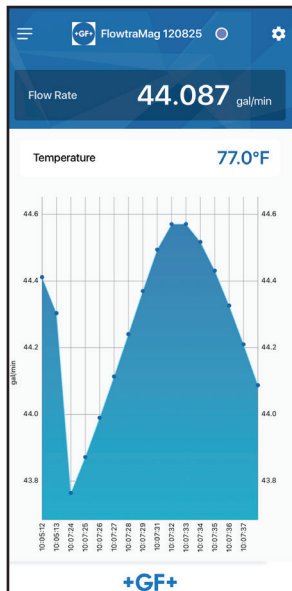

**Note:**

The logging screen only logs current screen view in real-time when connected to the app.

**NOTE:**

Temperature Units on Bluetooth® app will not be available for *Hastelloy C*. (Function will display: nan °C.)

## App Configuration - Files

Share and/or Save files

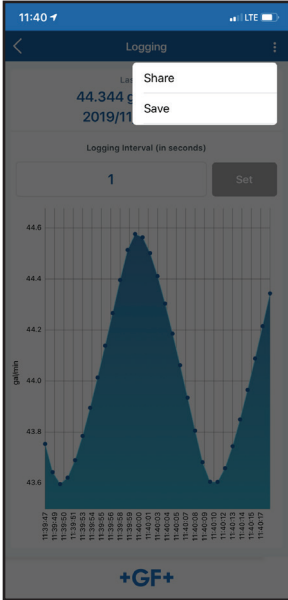

Naming files

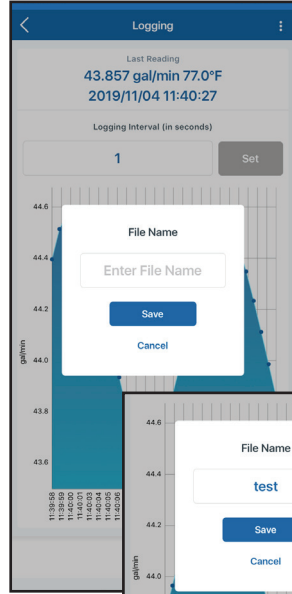

Create filename

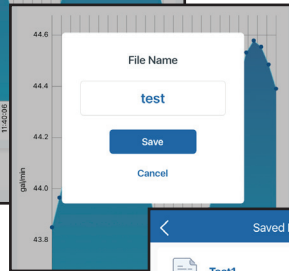

The file will be saved at mobile/tablet device under the Saved Log Files

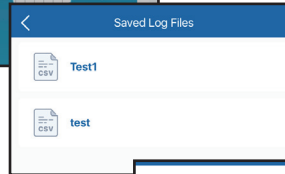

Then files can be sent by Email with .csv file format

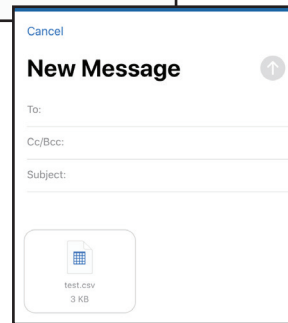

To delete saved files, slide to the right and click trash can

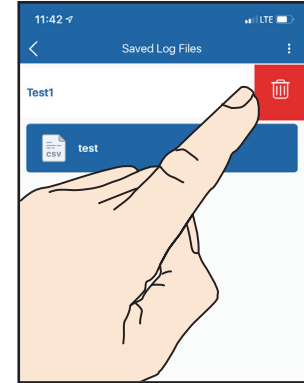

## App Configuration - Sensor Setup

**READ**      **WRITE**      **SAVE**      **LOAD**

- Read** Loads the data from the connected device (sensor or transmitter) and updates the software's display.  
**NOTE:** This will overwrite any changes made in the GF Config Tool App since the last **Write**.
- Write** Applies the data entered in the GF Config Tool App to the connected device. Once you have entered the desired setting changes in the software screens, press **Write** to load your new settings onto the connected device.
- Save** Stores the entire GF Config Tool App settings configuration, as currently displayed in the application, to your mobile device. (You will be asked to provide a configuration file name)
- Load** Loads a default configuration file from the factory.  
Opens a previously saved settings configuration file. See **Save** function above.  
**NOTE:** The file must be a GF Config Tool App settings configuration file.  
The software will verify whether the user-selected file is the correct type.  
There are configuration files available for specific body sizes containing default values from the factory. Carefully review the **Device Tag** and **Passkey** configuration in the Information screen.  
**Device Tag** identifies the sensor you are connecting to. Device Tag maximum length 20 characters.  
**Device Passkey** is needed for connecting to the sensor. Device Passkey is a 6 digit number.

# App Configuration - Sensor Setup Continued

## Application Setup

To set Averaging, Sensitivity, Low Flow Cut Off, Position of Flow, Flow Units, and Totalizer Unit,

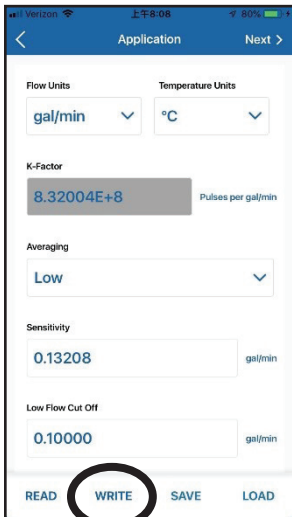

## Loop

Set 4 mA, 20 mA, Error condition of the current output alarm (3.6 or 22 mA), adjust your 4 to 20 mA setting and select output mode.

Loop adjustment is a live update.

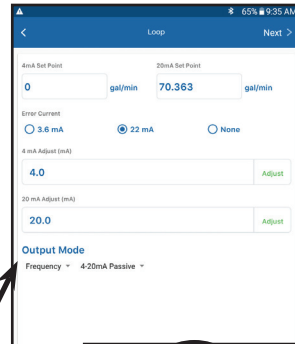

## Information

Sensor information, Permanent Totalizer, and Resettable Totalizer.

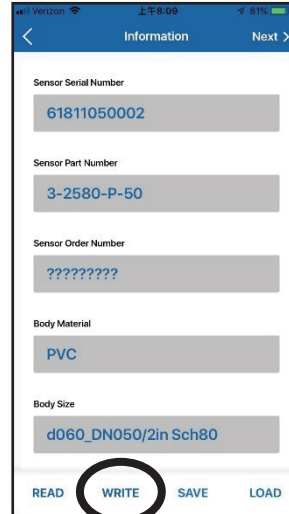

## Calibration

Custom Calibration of Rate, Volumetric, Zero Flow Calibration.

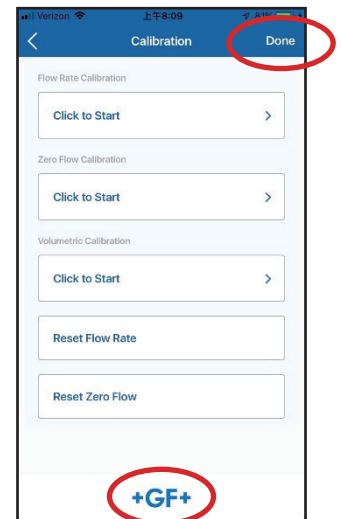

**You must press WRITE to save your changes to the sensor.**

Otherwise it saves to your phone only.

Then press **DONE** or press on **GF logo** to get back to re-connect screen.

To switch between S<sup>3</sup>L and Frequency and/or 4 to 20 Active or Passive, use the GF Config Tool App. On the loop screen, use the drop down to select S<sup>3</sup>L or Freq and/or Active or Passive 4 to 20 mA. Press WRITE after making selection.

If the GF Config Tool password has been lost or forgotten, connect blue wire to white wire of the sensor output cable while unit is powered (for 2 to 5 seconds.) Disconnect blue wire from white wire after 5 seconds. Password will reset to factory original (last 6 digits of serial number.)

To delete saved 2580 FlowtraMag in iOS: Swipe right and select the trash can icon.

To delete saved 2580 FlowtraMag in Android: Swipe right, "Are you sure you want to delete this device?", choose Yes or No.



## Technical Note

The totalizer in the 2580 FlowtraMag is independent from the totalizer in the 9900/9950 transmitters. If the totalizer is reset on the 2580 FlowtraMag, it does not reset the totalizer on the 9900 or 9950.

## Change Language

Currently English and Chinese are available in the App.

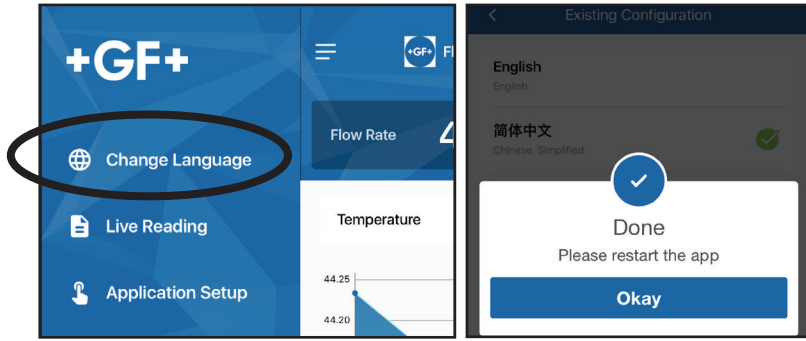

### Android

When you select your language of choice, it automatically changes. No other steps are needed.

## Close App

### iOS device with home button

Double click the home button. Find the minimized app and swipe up to close the app to clear the App Cache.

### iOS device without home button

Swipe up from the bottom. Find the minimized App and swipe up to close the app to clear the App Cache.

## Calibration

No calibration is necessary to begin using the 2580 FlowtraMag. The application and performance settings are pre-set to meet the requirements of most applications. The FlowtraMag is shipped from the factory with the following calibration:

| FlowtraMag Model | K-Factor pulse/L | K-Factor pulse/Gal | Flow Rate @20 mA L/min | Flow Rate @20 mA Gal/min |
|------------------|------------------|--------------------|------------------------|--------------------------|
| DN25 (1 in.)     | 225.264          | 852.716            | 266.35                 | 70.363                   |
| DN50 (2 in.)     | 53.9278          | 204.139            | 1112.6                 | 293.92                   |
| DN100 (4 in.)    | 13.7683          | 52.1188            | 4357.8                 | 1151.2                   |

### Application Note:

The unit is factory calibrated for recommended setup. See calibration certificate for complete details. User has the option to custom calibrate based on their application.

## Customization and Performance Settings

For customization and performance settings, use the GF Config Tool App or the Signet 0252 Configuration Tool and software. Refer to the Signet 0252 Configuration Tool manual for details to adjust the following parameters:

- 4 to 20 mA span:** Factory setting is 4 mA = 0, and 20 mA = 10 m/s (32.8 ft/sec) equivalent flow rate, refer to the calibration table, and can also be customized to any range. The 4 to 20 mA span sets the LED bar graph span.
- Low Flow Cutoff:** Factory setting is 0.02 m/s (0.07 ft/s) equivalent flow rate, and can be customized to any user preferences.
- Averaging Time:** Factory setting is Low. Can be customized: Off, Low, Med, High.
- Sensitivity:** Factory setting is 0.5 m/s (1.64 ft/s) equivalent flow rate, and can be customized to user preferences.

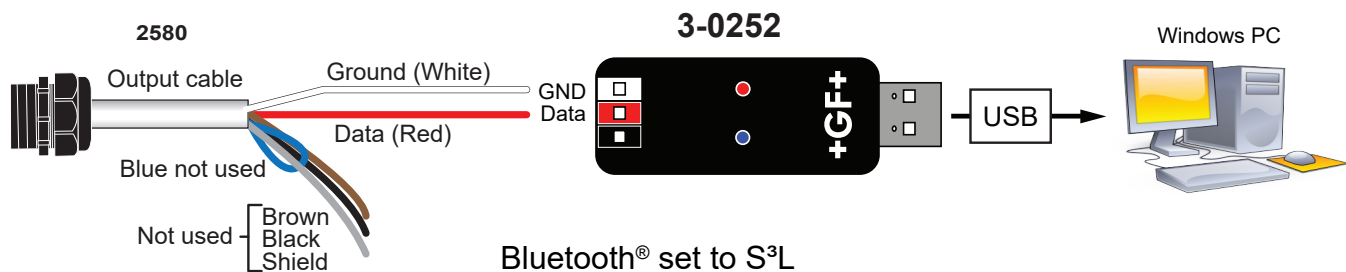

## Averaging and Sensitivity Settings

- Because ideal flow conditions are often impossible to achieve, the fluids flow is often erratic, which causes erratic readings in control features (e.g., relays, 4 to 20 mA loops, etc.) that are associated with the flow rate.
- The best solution to these problems is to correct any piping deficiency that causes the instability. This may involve longer straight runs upstream, taking steps to ensure pipe remains full during flow conditions, and other installation changes. In many situations, however, these measures are simply not possible.
- The 2580 FlowtraMag provides two tools that are designed to "work around" these deficiencies. The Averaging and the Sensitivity features should be studied before making adjustments.

### Averaging Time in Seconds (Factory set: Low)

- Set the time the meter will use as the averaging period. The ranges are Off, Low (10 s), Med (40 s) and High (120 s). Use higher averaging times to smooth the display and current output where the flow in the pipe is erratic.

### Quick Response Sensitivity (Factory Set: 0.5 m/s (1.64 ft/s) equivalent)

- Sets an amount of flow rate change at a given reference flow rate required to momentarily allow the 2580 FlowtraMag to change from the selected averaging time to a faster response. The reference flow rate should be near the range of normal operation. Turn the averaging setting to off and observe the flow rate variation, enter a sensitivity amount that is two times larger than the amount of flow variation.

#### ■ ■ ■ ■ ■ No AVERAGING, no SENSITIVITY

With AVERAGING set to Off and with SENSITIVITY set to zero, the 2580 FlowtraMag responds to every unstable shift in the flow. The dashed red line represents the actual output of the flow sensor in unstable flow conditions.

#### ● ● ● ● ● AVERAGING only

With AVERAGING set to Medium and SENSITIVITY still set to zero the flow rate is stabilized, but a sharp change in flow rate is not represented for 50 seconds or longer (dotted green line).

#### — AVERAGING and SENSITIVITY

With AVERAGING at Medium and SENSITIVITY set to a moderate amount, the flow rate is stabilized, while the sudden shift in flow is reflected very quickly (solid blue line).

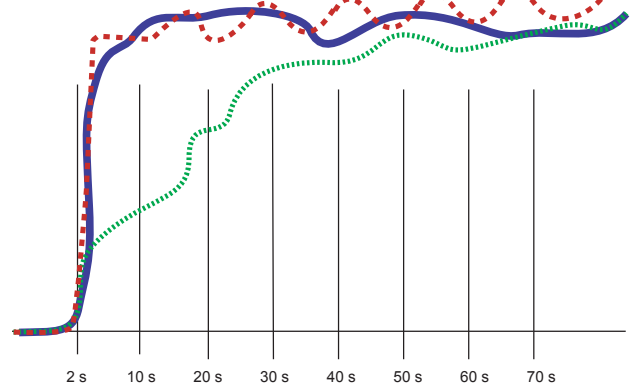

**NOTE:** The SENSITIVITY function is ineffective if the AVERAGING function is set to off (seconds).

## LED Status Indicators

LEDs on the 2580 FlowtraMag circuit board are useful to identify problems with the meter and the flow conditions.

| LED Condition   | Indication   |
|-----------------|--|
| All Off         | The power is off or the sensor is not connected  |
| Solid Blue      | Normal operation, full pipe, no flow   |
| Blinking Blue   | Normal operation, blink rate is proportional to flow rate                              |
| Solid Purple    | Partially filled pipe, flow rate is zero   |
| Blinking Purple | Partially filled pipe, blink rate is proportional to flow rate                         |
| Blinking Red    | Measurement out of range. If condition persists, will turn to solid red after 1 minute |
| Solid Red       | Instrument error, defective electronic component. Contact Technical Support            |
| 📶 Green         | 📶 - Connected device   |
| 📶 White         | 📶 - No connections   |

## Configuration - 0252 Tool

This is an outline. For complete instructions, please refer to the 0252 Configuration Tool manual.

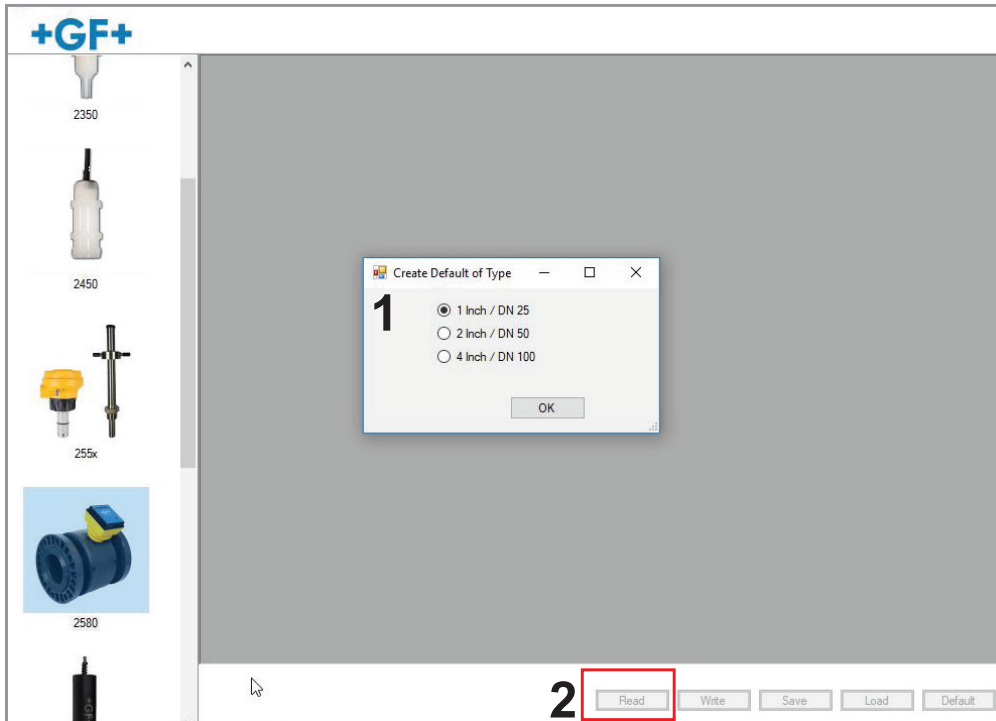

1. Select default unit by type.
2. Then click on **Read** from the device.

3

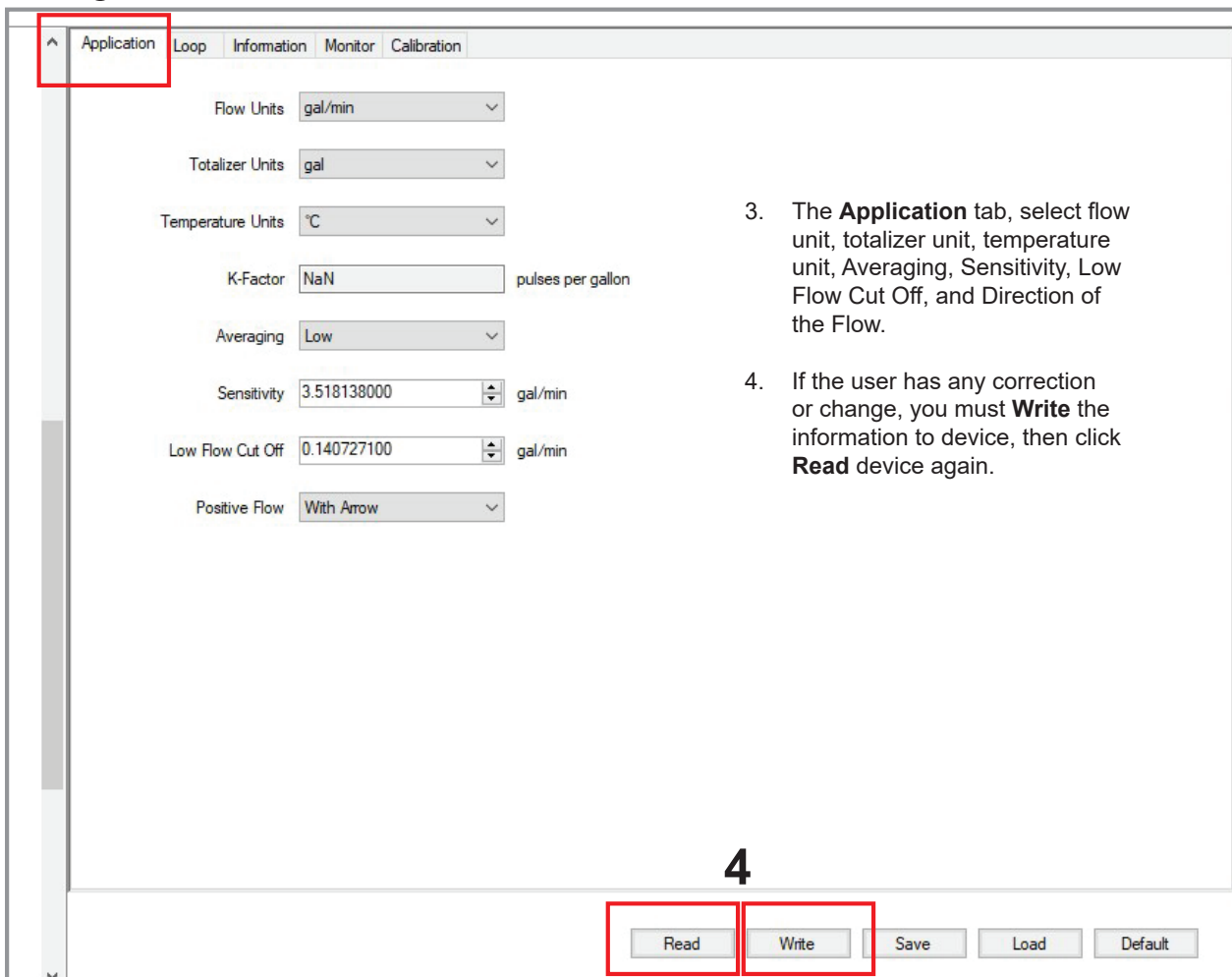

3. The **Application** tab, select flow unit, totalizer unit, temperature unit, Averaging, Sensitivity, Low Flow Cut Off, and Direction of the Flow.
4. If the user has any correction or change, you must **Write** the information to device, then click **Read** device again.

5

5. The **Loop** tab, select or confirm your 4 to 20 mA set point, set your current alarm condition, and type of output mode.

Application | **Loop** | Information | Monitor | Calibration

4mA Set Point: 0.00000000 gal/min

20mA Set Point: 285.310500000 gal/min

Error Current:  3.6 mA  22mA  None

4mA Adjust: 4 mA

20mA Adjust: 20 mA

Current Output Mode:  Active  Passive

Frequency / S3L Output Mode:  Frequency  S3L



**Note:**  
The 0252 Configuration Tool will be unable to connect to sensor when set to frequency.

6

6. The **Information** tab, displays product information, totalizer information, and Bluetooth® data.

Application | **Information** | Loop | Monitor | Calibration

Sensor Serial Number:

Sensor Part Number:

Sensor Order Number:

Body Material:

Body Size:

Totalizers

Permanent Totalizer: 0 gallon

Resettable Totalizer: 0 gallon

Bluetooth Data

Device Tag: FlowtraMag XXXX

Device Passkey:

7

- 7. The **Monitor** tab can graph or log the information to your local drive via file type with the extension .CSV

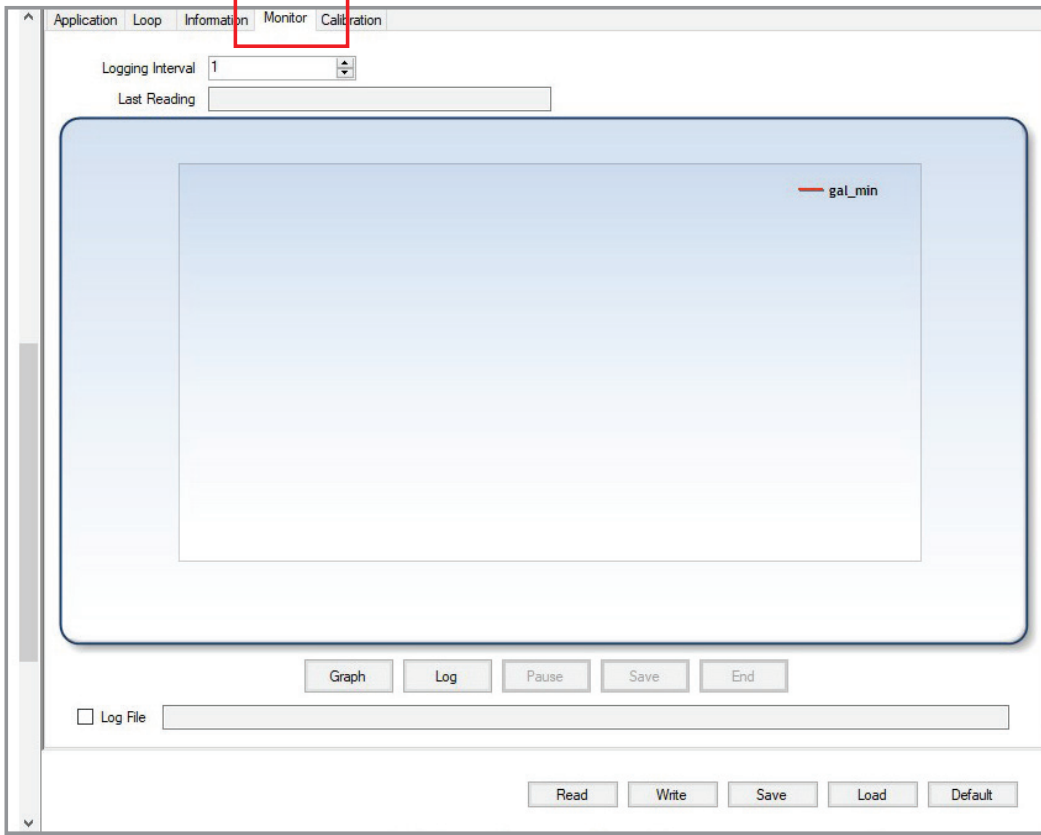

8

- 8. The **Calibration** tab, allows custom calibration via method of rate, volumetric, and zero flow calibration.

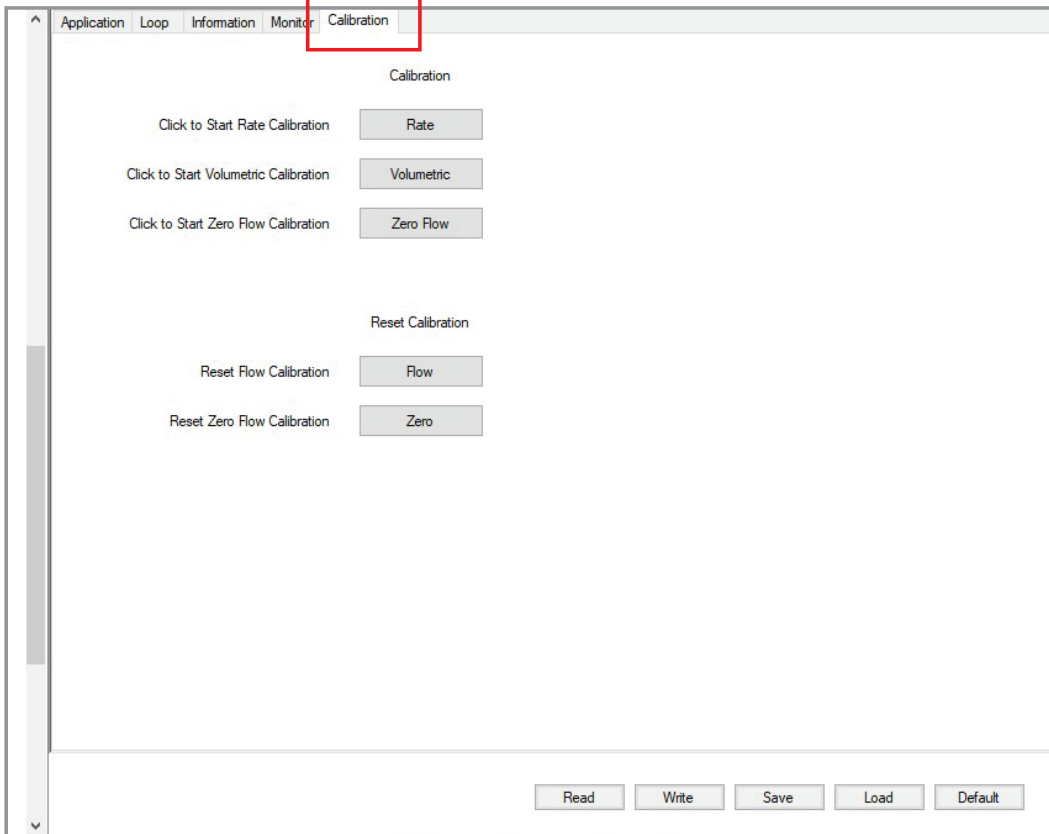

## Troubleshooting

| Symptom   | Possible Cause  | Solution   |
|---|---|--|
| No LED Lights                                   | Unit is not powered, or the power wiring is reversed.   | Check power wiring, voltage should be 12 to 32 VDC at 24W.   |
| Solid Blue                                      | There is no flow. If user expects to see flow, the Low Flow Cutoff value may be set too high.   | Change the Low Flow Cutoff value in user menu using GF Configuration Bluetooth® Tool or 0252 Configuration Tool.   |
| Solid Purple                                    | Partially filled pipe. Flow rate is zero.   | User should be aware that the pipe could be filled > 50% and water in the pipe is stagnant, or the water is below 50% and water could be stagnant or moving.   |
| Blinking Red                                    | Flow measurement is out of range. If error persists, the LED will become solid RED after one minute.  | The spiking of the flow outside the normal range could be caused by excessive EMI, or water splattering through a partially filled pipe and creating flow spikes. The spiking will end once the disturbance is not present anymore.  |
| Frequency output does not work                  | <ol style="list-style-type: none"> <li>1. Bluetooth selection is S<sup>3</sup>L.</li> <li>2. Improper wiring.</li> </ol>  | <ol style="list-style-type: none"> <li>1. Select frequency from GF Config Tool or 0252 Configuration Tool.</li> <li>2. Check wiring. Use the wiring diagram picture in the 2580 FlowtraMag manual.</li> </ol>  |
| Frequency, Digital or Current Output is Erratic | <ol style="list-style-type: none"> <li>1. Electrical Noise interference with the flow measurement.</li> <li>2. Possible air pockets traveling through the piping system.</li> <li>3. Pipe is not full and water flow creates splashing of the electrodes.</li> <li>4. Excess turbulence in fluid flow profile.</li> </ol> | <ol style="list-style-type: none"> <li>1. Verify the grounding of the 2580 FlowtraMag and of the nearby VFDs and Pumps. If possible, use grounding rings or connect metal portions of the piping to closest ground.</li> <li>2. Check the piping and use vents if possible, otherwise wait for the air pockets to be eliminated through the system.</li> <li>3. Try to keep the pipe full, by installing vertical.</li> <li>4. Follow product manual recommended xD installation distances.</li> </ol> |
| Output is not Zero when flow is stopped         | <ol style="list-style-type: none"> <li>1. Low Flow Cutoff flow value is lower than the zero flow noise level.</li> <li>2. Electrical noise is interfering with the measurement.</li> <li>3. Defective 2580 FlowtraMag.</li> </ol>   | <ol style="list-style-type: none"> <li>1. Adjust the Low Flow Cutoff value to be above the noise level.</li> <li>2. Verify/Modify Grounding.</li> <li>3. Contact Technical Support.</li> </ol>   |
| Forgotten password                              | Forgotten/lost password   | Connect blue wire to white wire while unit is powered (for 2 to 5 seconds.) Password will reset to factory original (last 6 digits of serial number.)  |

## Troubleshooting

| Symptom                                      | Possible Cause   | Solution   |
|--|--|--|
| Measurement inaccurate                       | <ol style="list-style-type: none"> <li>1. Improper calibration.</li> <li>2. Sensor fault as indicated by the Red LED.</li> <li>3. Media conductivity is lower than 20 <math>\mu\text{S}/\text{cm}</math>.</li> </ol>   | <ol style="list-style-type: none"> <li>1. Use the GF Config Tool App or 0252 Configuration Tool to reset flow and/or zero calibration. If user intends to calibrate using installed reference, proceed with zero and/or one point flow calibration.</li> <li>2. Cycle power, make sure there is no excessive electrical noise interference. If Red LED stays on, contact Technical Support.</li> <li>3. Check application and make sure the conductivity is above the specified 20 <math>\mu\text{S}/\text{cm}</math>.</li> </ol>  |
| User cannot communicate using the 0252 Tool  | <ol style="list-style-type: none"> <li>1. There is no digital (S<sup>3</sup>L) communication.</li> <li>2. The digital (S<sup>3</sup>L) wiring is improper.</li> </ol>  | <ol style="list-style-type: none"> <li>1. Select S<sup>3</sup>L from GF Config Tool or 0252 Configuration Tool.</li> <li>2. Check wiring as per manual.</li> </ol>   |
| User cannot communicate using the Bluetooth® | <ol style="list-style-type: none"> <li>1. The GF Config Tool App is not installed properly.</li> <li>2. The GF Config Tool App has not been identified properly.</li> <li>3. The GF Config Tool App does not connect.</li> </ol>   | <ol style="list-style-type: none"> <li>1. Check the Bluetooth® white light to be on.</li> <li>2. Use the GF Config Tool App to identify the FlowtraMag to connect to (use elimination method if more Bluetooth® units present.) Record the FlowtraMag's IDs, or delete unused sensors.</li> <li>3. Restart GF Config Tool App.</li> </ol>  |
| 4 to 20 mA output is incorrect               | <ol style="list-style-type: none"> <li>1. The 4 to 20 mA in the 2580 FlowtraMag is not scaled properly. The Instrument used with the FlowtraMag has the 4 to 20 mA input not matching the 2580 FlowtraMag.</li> <li>2. The setting and/or wiring for active / passive 4 to 20 mA is done incorrectly.</li> <li>3. Defective hardware.</li> </ol> | <ol style="list-style-type: none"> <li>1. Scale the current output in the 2580 FlowtraMag correctly using the GF Config Tool App or the 0252 Configuration Tool.</li> <li>2. Change the Instrument scaling to match the 2580 FlowtraMag.</li> <li>3. For active AO, select ACTIVE from the GF Config Tool or 0252 Configuration Tool. In this case, current output connects directly to AO 4 to 20 mA connector with correct polarity, see wiring in the 2580 FlowtraMag manual. For passive AO, select PASSIVE from the GF config Tool or 0252 Configuration Tool. Wiring is done from AO 4 to 20 mA connector using the loop power, as indicated in the 2580 FlowtraMag manual wiring diagram.</li> <li>4. If the Green LED bar, % output indicates correctly the % flow and the current output is not working properly, first check AO selection in GF Config Tool or 0252 Configuration Tool. If AO selection is correct, call Technical Support.</li> </ol> |
| Current Output at 3.6 mA or 22 mA            | There is an error condition in the 2580 FlowtraMag.  | Check status LED and follow existing guideline for troubleshooting.  |



## Ordering Information

| Mfr. Part No.      | Code         | Description   |
|--------------------|--------------|---|
| 3-2580-P-T-010     | 159 001 874  | FlowtraMag, PVC Union, FKM, Titanium, DN25 (1 in.)                                  |
| 3-2580-P-T-020     | 159 001 875  | FlowtraMag, PVC Union, FKM, Titanium, DN50 (2 in.)                                  |
| 3-2580-P-T-040     | 159 001 876  | FlowtraMag, PVC Flange, FKM, Titanium, DN100 (4 in.)                                |
| 3-2580-P-H-010     | 159 001 945  | FlowtraMag, PVC Union, FKM, <i>Hastelloy C</i> , DN25 (1 in.)                       |
| 3-2580-P-H-020     | 159 001 946  | FlowtraMag, PVC Union, FKM, <i>Hastelloy C</i> , DN50 (2 in.)                       |
| 3-2580-P-H-040     | 159 001 947  | FlowtraMag, PVC Flange, FKM, <i>Hastelloy C</i> , DN100 (4 in.)                     |
| <b>Accessories</b> |              |   |
| 3-0252             | 159 001 808  | 0252 Configuration Tool   |
| 854-040            | -            | 4 inch SCH 80 Van Stone Flange  |
| 37X002118          | -            | 4 inch FKM Full Face Flange Gasket - 150# ANSI bolt pattern                         |
| 37Z000069          | -            | 4 inch Van Stone Flange bolt kit 316 SS - 150#<br>(UNC bolts, SAE washers and nuts) |
| -                  | 721 790 114  | DN100 Flange Adapter, PVC-U Metric  |
| -                  | 721 700 014  | DN100 Backing Flange, PVC-U Metric  |
| -                  | 161 375 904C | d32/DN25 Union End, metric  |
| -                  | 161 375 907C | d63/DN50 Union End, metric  |
| -                  | 161 375 430C | PVC 1" Union End  |
| -                  | 161 375 433C | PVC 2" Union End  |
| 3VGHR0A32C         | -            | PVC ASTM / Union Nut, metric DN25 & 1"  |
| 3VGHR0A63C         | -            | PVC ASTM / Union Nut, metric DN50 & 2"  |
| 9152-219           | -            | ASTM / O-Ring, metric DN25 & 1"   |
| 9152-332           | -            | ASTM / O-Ring, metric DN50 & 2"   |
| -                  | 749 440 714  | DN100 Flange Profile Gasket   |



Georg Fischer Signet LLC, 3401 Aero Jet Avenue, El Monte, CA 91731-2882 U.S.A. • Tel. (626) 571-2770 • Fax (626) 573-2057  
For Worldwide Sales and Service, visit our website: [www.gfsignet.com](http://www.gfsignet.com) • Or call (in the U.S.): (800) 854-4090  
For the most up-to-date information, please refer to our website at [www.gfsignet.com](http://www.gfsignet.com)