



# Signet 2350 Temperature Sensor



3-2350.090-1 Rev. 12 01/19

## Product Manual



### Description

The Signet 2350 Temperature Sensor has a one-piece injection molded PVDF body that is ideal for use in high purity applications. It also outlasts metal sensors in aggressive liquids and eliminates the need for costly custom thermowells. These sensors are available with Digital (S<sup>3</sup>L) or field-scaleable 4 to 20 mA output. Dual threaded ends (3/4 in. NPT) allow submersion in process vessels, or in-line installation with conduit connection. Integral adapters (sold separately) may be used to create a compact assembly with field mount style of the 9900 Transmitter.

### Dimensions

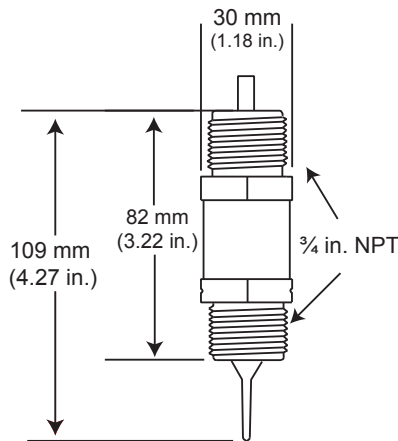

### Pressure/Temperature Graph

#### Application Limits

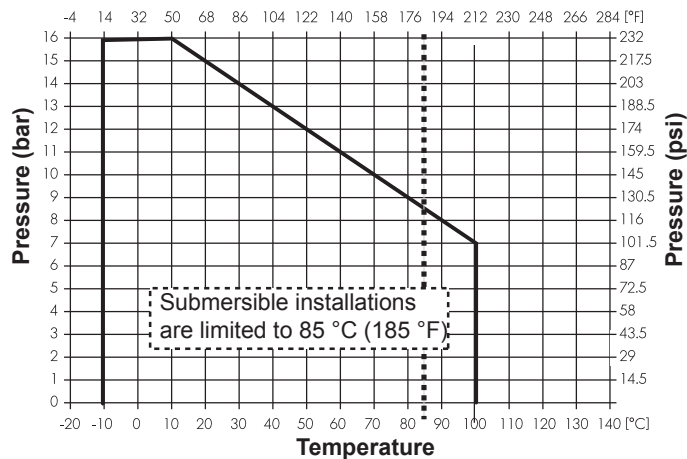

- [English](#)
- [Deutsch](#)
- [Français](#)
- [Español](#)
- [中文](#)





## Installation

The compact integral assembly can be installed using the following directions:

### 2350-1 Integral Assembly Sensor Modification

- Modify sensor part number 3-2350-1 per figure 1.
- Apply sealant or PTFE tape to the process connection threads per figure 2, after inspecting threads to ensure integrity. Do not install a sensor with damaged threads.
- Thread the sensor into the 3-8052 mounting kit.
- Tighten the sensor 1½ turns past finger tight into the process connection.
- Make sure the flow alignment indicator is in correct position in the pipe. Damage to the sensor tip can occur if the sensor tip is installed improperly.
- Install 9900 Transmitter (refer to 9900 manual for wiring information).
- The 3-8052 Integral kit includes:
  - ¾ in. NPT process connection
  - 3-9000.392-1 liquid tight connector, ½ in. NPT

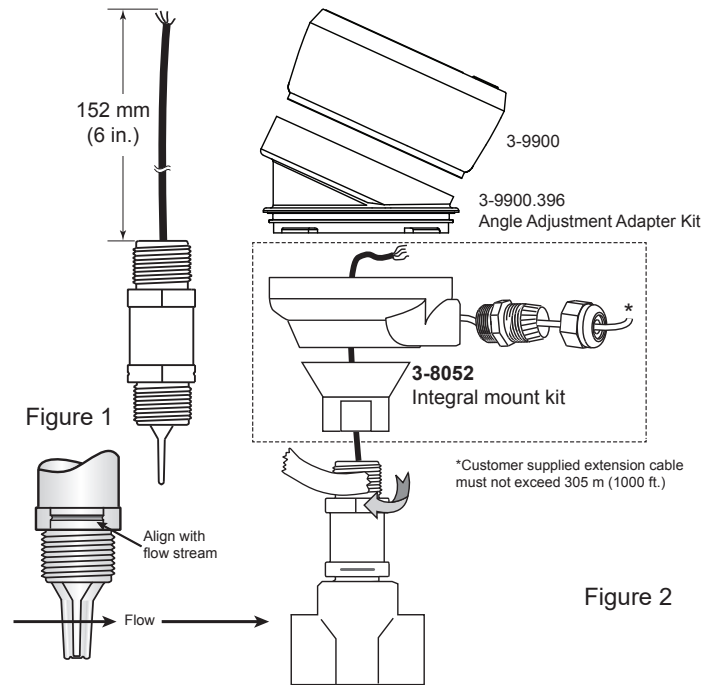

### 2350-3 In-line Remote Assembly

The optional 3-8052-1 Integral Junction box with ¾ in. process connection offers a convenient terminal point to extend the 2350 cable over distances greater than 4.6 m (15 ft).

- The kit includes:
  - ¾ in. NPT process connection
  - Conduit base and cap with junction terminals
  - 3-9000.392-1 liquid tight connector, ½ in. NPT

To extend the wires longer than 4.6 m (15 ft):

- Modify sensor 3-2350-1 or 3-2350-3 as described in figure 1.
- Terminate the three wires to the terminal board located in the cap assembly.
- Add customer-supplied wire to extend the cable.
- Terminate to the transmitter or the 4 to 20 mA input device.
- Apply sealant or PTFE tape to the process connection threads per figure 3, after inspecting threads to ensure integrity. DO NOT install a sensor with damaged threads.
- Tighten the sensor 1½ turns past finger tight into the process connection.

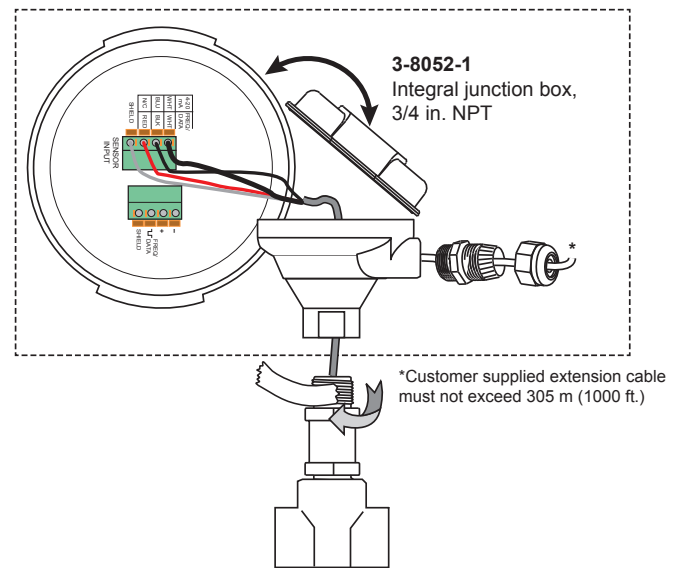

### 2350-1 or 2350-3 Submersible Installation

- Use the 2350-1 or 2350-3 sensor with 4.6 m (15 ft) cable.
- Mount the sensor to an extension pipe or watertight conduit using thread sealant.
- Use a cable gland at the top of the extension to prevent moisture intrusion/accumulation inside the pipe.
- For additional defense against possible accumulation of condensation at the back seal area of the sensor, fill the lower 75 mm to 100 mm (3 in. to 4 in.) of conduit or extension pipe with a flexible sealant such as silicone.



#### CAUTION!

The fluid temperature must not exceed 85 °C (185 °F) in submersible installations.

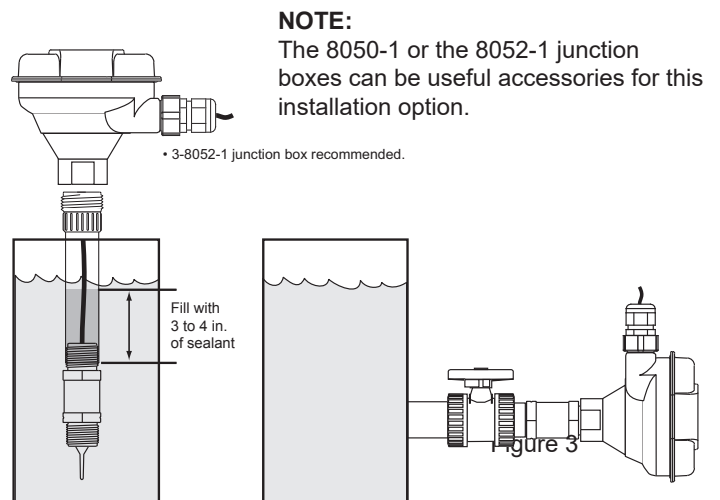

#### NOTE:

The 8050-1 or the 8052-1 junction boxes can be useful accessories for this installation option.

## Digital (S<sup>3</sup>L) Wiring

- All models of the 2350 provide Digital (S<sup>3</sup>L) output when powered with 5 VDC.
- Connecting the SHIELD to a direct Earth ground may reduce electrical noise interference.
- The maximum Digital (S<sup>3</sup>L) cable length is dependent upon the instrument to which the sensor is connected. Consult the instrument manual for details.
- Connect the 2350 cable directly to Digital (S<sup>3</sup>L) I/O terminals.

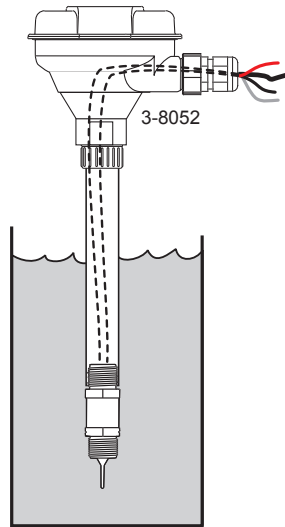

### 3-9900 S<sup>3</sup>L connector

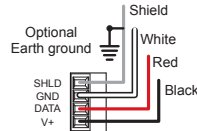

### 3-8900 I/O Module Connector

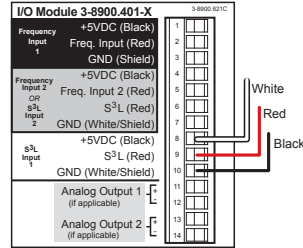

### 3-9950 S<sup>3</sup>L connector

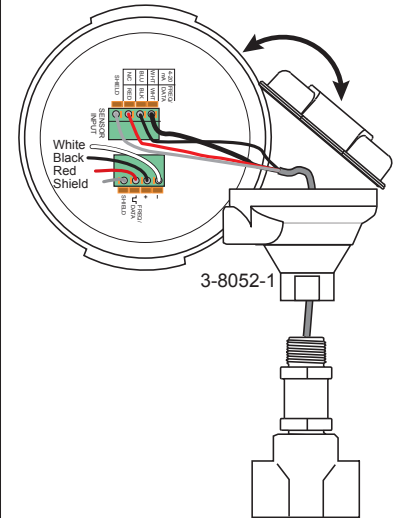
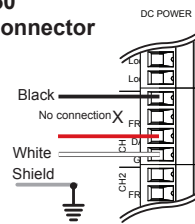

- When the 2350 includes a junction box, connect the 2350 terminals to any Digital (S<sup>3</sup>L) I/O port as shown.

## 4 to 20 mA Loop Wiring

- The 2350-3 provides a 4 to 20 mA loop output when powered with 12 to 24 VDC.
- Connecting the SHIELD to a direct Earth ground may reduce electrical noise interference.
- Red wire is not used, do not remove the heat shrink. See 4 to 20 mA Span Adjustment, page 5.

### Current Loop With No Junction Box

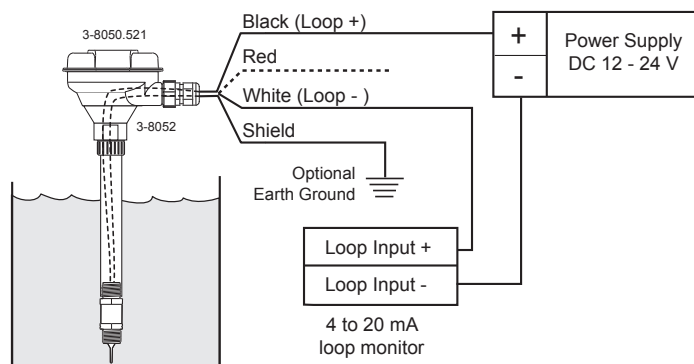

- Connect the 2350 cable directly to a loop device as shown.

### Current Loop With Junction Box

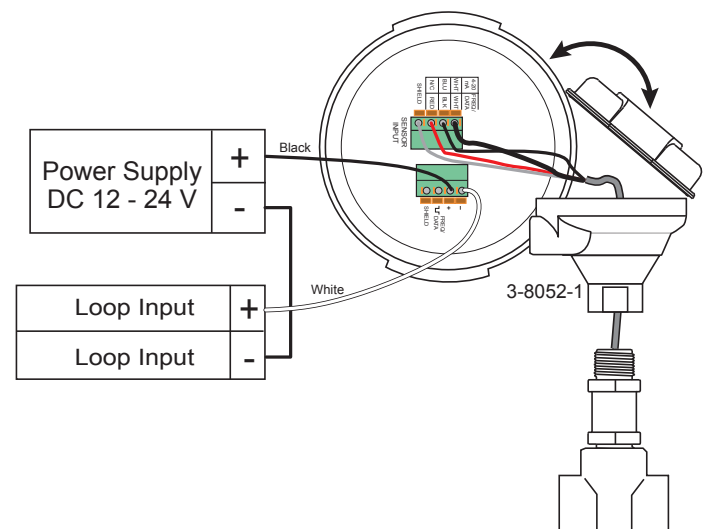

- When the 2350 includes a junction box, connect the 2350 terminals to a loop device as shown.

## 4 to 20 mA Span Adjustment

The 4 to 20 mA endpoint values are independent of one another and may be adjusted in the field. For example, to reduce the 20 mA endpoint value from the factory setting of 100 °C, but to allow the 4 mA endpoint to remain at 0 °C, perform only the steps listed below.

**NOTE:** The RED wire, which is not connected during normal 4 to 20 mA operation, assumes an important role in the following procedures.



### WARNING!

Not protecting the red wire may cause the 4 to 20 mA span to be reset.

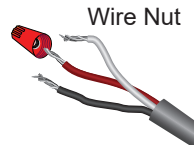

### To adjust the 4 mA endpoint in the field:

- Carefully remove the heat shrink tube protecting the red wire.
- Expose the sensor to the temperature desired to correspond with 4 mA -10 °C to 100 °C (submersible: -10 °C to 85 °C).  
(Be sure to allow sufficient time for the sensor to reach equilibrium.)
- With power applied as described on page 4, connect the RED wire to the WHITE wire for 15 seconds.  
(After about 10 seconds the output will drop to 3.6 mA and remain there until the RED wire is disconnected.)
- Disconnect the RED wire from the WHITE wire; the 4 mA endpoint has been adjusted.
- **NOTE:** The output will act as a switch if the 4 and 20 mA endpoints are set very near to the same value.

### To adjust the 20 mA endpoint in the field:

- Expose the sensor to the temperature desired to correspond with 20 mA -10 °C to 100 °C (submersible: -10 °C to 85 °C).  
(Be sure to allow sufficient time for the sensor to reach equilibrium to this temperature.)
- With power applied as described in on page 4, connect the RED wire to the BLACK wire for 15 seconds.  
(After about 10 seconds the output will rise to 22 mA and remain there until the RED wire is disconnected.)
- Disconnect the RED wire from the BLACK wire; the 20 mA endpoint has been adjusted.

**NOTE:** The output will act as a switch if the 4 and 20 mA endpoints are set very near to the same value.

- Minimum span is  $\pm 2\%$  of maximum range.
- After adjusting the 4 to 20 mA span, protect the red wire by installing the provided wire nut.
- For easier re-spanning use the Signet 0252 Configuration Tool.

### To restore the factory setting:

- Disconnect power to the sensor. Wait 10 seconds for circuit to discharge.
- Connect the RED wire to the WHITE wire.
- Apply power as described on page 4, but with the RED wire connected to the WHITE wire for 15 seconds.  
(After about 10 seconds the output will drop to 3.6 mA and remain there until the RED wire is disconnected.)
- Disconnect the RED wire from the WHITE wire; factory settings have been restored.

Mfr. Part No.	Factory Span
3-2350-3	4 to 20 mA = 0 °C to 100 °C

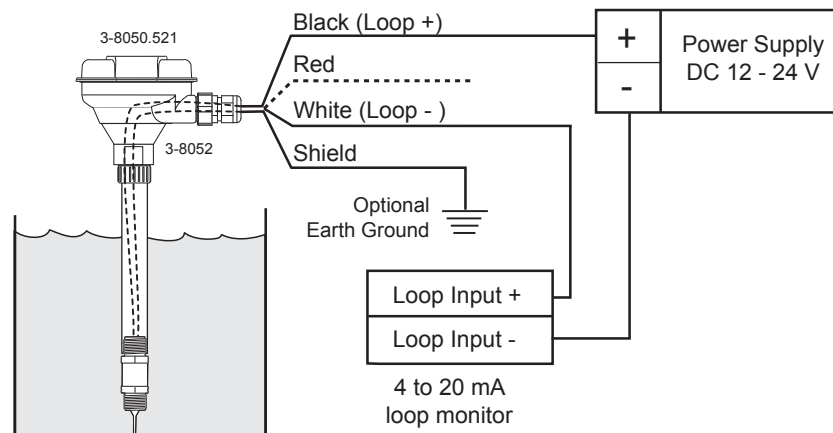





## Ordering Information

Mfr. Part No.	Code	Description
3-2350-1	159 000 021	Temperature sensor, (S <sup>3</sup> L) output, 3/4 in. NPT, 4.6 m (15 ft) cable
3-2350-3	159 000 920	Temperature sensor, 4 to 20 mA output, 3/4 in. NPT, 4.6 m (15 ft) cable

### Accessories

Mfr. Part No.	Code	Description
3-8050-1	159 000 753	Universal mount junction box
3-8052	159 000 188	3/4 in. Integral mounting kit
3-8052-1	159 000 755	3/4 in. NPT mount junction box
3-9000.392-1	159 000 839	Liquid tight connector kit, NPT (1 piece)
3-9000.392-2	159 000 841	Liquid tight connector kit, PG13.5 (1 piece)
3-9900.396	159 001 701	Angle Adjustment Adapter Kit
5523-0322	159 000 761	Cable, 3 conductor + shield, 22 AWG, black/red/white/shield
3-0252	159 001 808	Configuration Tool
	contact factory	Custom cable length available



Georg Fischer Signet LLC, 3401 Aero Jet Avenue, El Monte, CA 91731-2882 U.S.A. • Tel. (626) 571-2770 • Fax (626) 573-2057  
For Worldwide Sales and Service, visit our website: [www.gfsignet.com](http://www.gfsignet.com) • Or call (in the U.S.): (800) 854-4090  
For the most up-to-date information, please refer to our website at [www.gfsignet.com](http://www.gfsignet.com)