



DRUM/BARREL MIXER TM SERIES

Sealed, Low/Medium Viscosity

Sealed mixer with 4-blade turbine mixing/blending capability. Ideal for rapid suspension of settled solids.

- 316 stainless steel tube construction
- Top-to-bottom mixing action
- Interchangeable with motors
- Up to 1000 cP with air or electric motor



Applications:

Dyes, inks, paints, solvents[†], mild corrosives, flammables

TMS

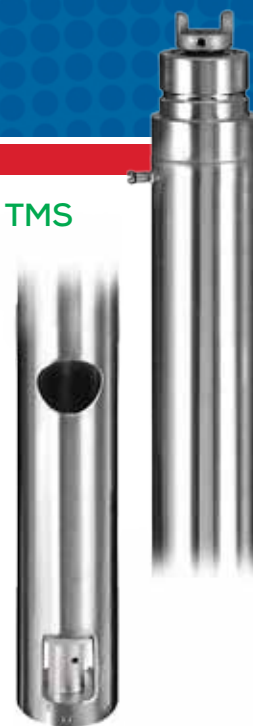

CONSTRUCTION SPECIFICATIONS

Model	Construction Materials		Tube Dia. in (cm)	Tube Length in (cm)	Max. Temp.		Min. Temp.	
	Outer Tube	Internals			°F	°C	°F	°C
TMS	316 Stainless Steel	316 Stainless Steel, PTFE	2 (5.1)	40 (102)	200	93	-20	-29

[†]When mixing flammables or combustibles, use explosion proof electric or air drive motors on stainless steel tubes with static protection kit.

Performance Data

Maximum Circulation	Maximum Specific Gravity	Maximum Viscosity
14 gpm (53 lpm)	1.8	1,000 cP

- Top-to-bottom mixing action allows rapid suspension of settled solids.
- Pulls lighter liquid from top and discharges under pressure out the bottom of the mixer tube.



Use the handy online Pump Selector at www.finishthompson.com for help choosing a pump.

DRUM/BARREL PUMPS

MOTOR DATA



TEFC
(M7TV, M8TV)



Ex-Proof
(M7XV, M8XV)



Air
(M6, M6X)

Model	Description	Certification	Electrical Requirements	Input	Output	RPM
				W	W	
TEFC (Totally Enclosed Fan Cooled), IP55 Motors						
M7TV	Continuous duty. 12 ft. (3.5 m) cord with plug, downdraft cooling and quick connection to pump without tools. Variable speed, solid state overload protection, zero voltage release.	CSA	115VAC/60 Hz	450	250	0 - 6,000
M8TV		CE	230VAC/50-60 Hz	450	250	0 - 6,000
Explosion Proof Motors						
M7XV	Continuous duty, IP55. 12 ft. (3.5 m) cord without plug, downdraft cooling and quick connection to pump without tools. Variable speed, solid state overload protection, zero voltage release.	CSA	115VAC/60 Hz	450	250	0 - 6,000
M8XV		CE	230VAC/50-60 Hz	450	250	0 - 6,000
Air Motors[†]						
M6	Lightweight. Operates from customer-supplied compressed air source. Variable speed. Muffler and control valve.	CE	80-100 psi @ 15-32 cfm	-	400	300-9,000
M6X		CE	80-100 psi @ 15-32 cfm	-	600	300-6,000

*An air motor is a non-electrical device meaning possibility of explosion from igniting flammables/combustibles is reduced. Air motor performance will depend upon user's system setup.

DIMENSIONS

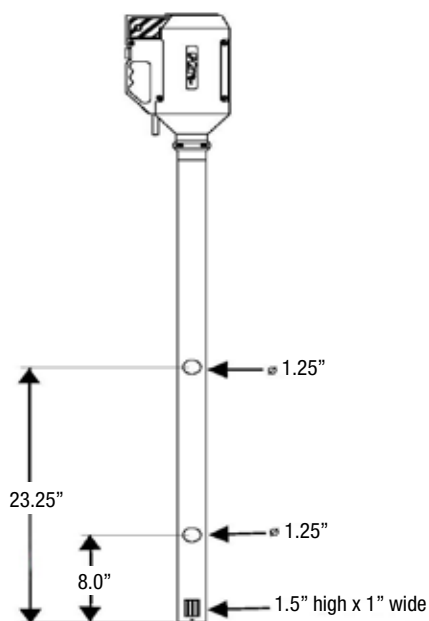

ACCESSORIES

Drum Adapters



Static Protection Kit



Air Hose Assembly



Filter Lubricator Assembly



finishthompson.com

FINISH THOMPSON INC. - HEADQUARTERS

921 Greengarden Road | Erie, PA 16501
800.934.9384 | ph 814.455.4478 | fx 814.455.8518
email fti@finishthompson.com

FINISH THOMPSON INC. - EUROPE CENTER

Otto-Hahn-Strasse 16 | Maintal, D-63477 Germany
49 (0)6181-90878-0 | fx 49 (0)6181-90878-18
email fti@finishthompson.com