

EchoPod®

Ultrasonic Liquid Level Transmitter



UG06 & UG12 Series Quick Start



©2017 Flowline, Inc.
All Rights Reserved
Made in USA

WELCOME TO THE ECHOPOD® QUICK START

The EchoPod® Quick Start provides basic mounting, setup and use instructions for getting the EchoPod® up and running quickly. If you have a non-standard installation or setup requirement that is not addressed here, please refer to the EchoPod® Manual or other support documentation located at flowline.com.

WE DO YOUR LEVEL BEST

Thank you for purchasing EchoPod®. The sensor provides integrated LCD and three push-button configuration. This quick start includes everything you'll need to get the sensor up and running.

COMPONENTS

Depending on how the sensor part number that was shipped, EchoPod® comes with a Viton® gasket for installation and the Quick Start.



EchoPod®
UG06-0001-00
UG06-0001-01
UG06-0011-00
UG06-0011-01



EchoPod®
UG12-0001-00
UG12-0001-01
UG12-0011-00
UG12-0011-01



USB® Key Fob
P/N: LI99-2001

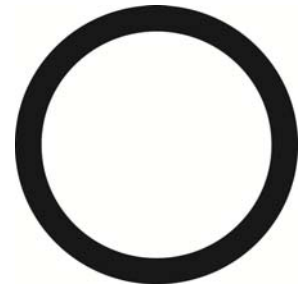

Viton® gasket (2")
P/N: 200129
G threaded version only

ENCLOSURE

While the switch housing is liquid-resistant the EchoPod® is not designed to be operational when immersed. It should be mounted in such a way that the enclosure and transducer do not come into contact with the application media under normal operational conditions. Before closing the enclosure, make sure that the enclosure gasket is properly seated, and that any conduit fittings, cable connectors or plugs are installed correctly and sealed. **Note:** If using the Flowline LM90-1001 (liquid tight fitting) on the 1/2" conduit, the cable minimum is 0.170" (4.3mm) and the maximum is 0.450" (11.4mm).

CONFIGURATION

When configuring EchoPod®, choose either the WebCal® or Push Button method. Either method will accomplish the goal of sensor configuration. Changes to the configuration can be made using the alternative method. When beginning with one method, it is recommended to complete the configuration before using the other method to make any adjustments.

Note: When connecting the sensor to the WebCal® Software, you must remove the display or the software will not connect. Once completed, you can re-connect the display to the terminal.

CONFIGURING ECHOPOD® (WEBCAL)

EchoPod® is configured through WebCal®, a PC software program. Configuration of your sensor should be performed prior to mounting, since it requires connection to your PC.

STEP 1: INSTALL WEBCAL® SOFTWARE

Download WebCal® software from www.flowline.com/webcal-software onto a PC with the following minimum specifications:

Windows® 2000/XP/Vista/7/8/10, 10 MB storage space, 256 MB RAM, 1 USB® 2.0 port

You must have an active Internet connection to download WebCal®. Double-click the WebCal® installer to install software before proceeding to Step 2. Installer program will automatically install any required drivers.

STEP 2: CONNECT THE USB® FOB

NOTE: Do not connect the Fob to your computer until after you've installed WebCal® software.

The sensor communicates to WebCal® through the USB® Fob. Prior to plugging the Fob into your computers USB® port, ensure that all external power is disconnected from EchoPod®. The maximum distance between the computer and EchoPod® is 15'.

1. Connect the proper terminals from the EchoPod® to the corresponding colored terminals on the Fob.
 - a. Power (+) to Red
 - b. Power (-) to Black
 - c. WebCal (W) to White
 - d. WebCal (G) to Green
2. Tighten the terminal screws with a slotted screwdriver.
3. Plug the Fob into your PC's USB® port.

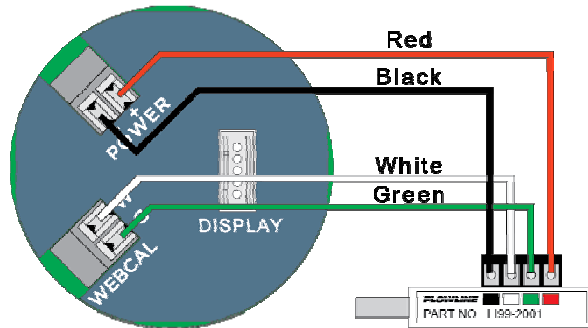

Wiring identical for all series – Use only the Red, Black, Green and White wires.

Note: When connecting the sensor to the WebCal® Software, you must remove the display or the software will not connect. Once completed, you can re-connect the display to the terminal.

STEP 3 - MEASURE THE TANK

Measuring the tank is one of the most important aspects in configuring the sensor. When measuring the tank, take into account the location of the sensor with respect to fittings, risers, dome tops and bottoms, and identify where the measurements are taken from the sensor. The HEIGHT and FILL-H settings determine the 4-20mA span and are always measured from the bottom of the tank up.

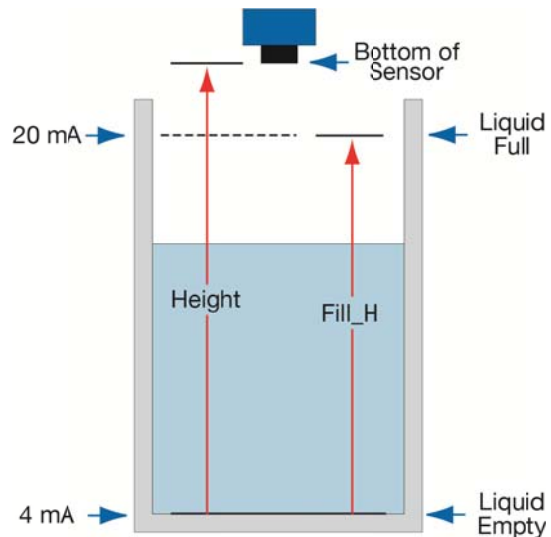

STEP 4 - SENSOR CONFIGURATION

Configures the Loop Fail-Safe, Output at Empty and Startup Condition for the sensor.

Configuration Updates

Model Number UG06

FLOWLINE™

Part Type: UG06, Serial Number: 1001 Firmware: UG6p00
Description: Transmitter, 236.22" (6.0m) FW Rev: 1

Config

Loop Fail-Safe
Overfill (22 mA)

Output at Empty
4 mA at Bottom

Startup Condition
Empty

Levels

Height Units: inches Sensor Height: 236.22 Fill Height: 228.34

Vertical Cylinder

20mA
Sensor Height
4mA
Fill Height

Volumetric Mode

Notes

Config #0

Write to Unit
Wiring Diagram
Advanced
Factory Config
Clear Screen
Config File Name
Open Config File
Save Config File
Print Config File
Help

STEP 5 – DIMENSIONAL ENTRY

Distance Mode (default): Output of sensor is based on the distance (height of liquid) in the tank. Any change in liquid level will reflect linearly to the current output. The two values (Sensor Height and Fill-Height) below set the 4-20 mA current span for the sensor. Both values will be set in the units shown under Height Units.

Height Units: Confirm units for use in Sensor Height and Fill-Height settings.

Sensor Height: Sets the location for 4mA. It is based on the distance from the Empty level position to the Measurement location for the sensor (see below).

Fill-Height: Sets the location for 20mA. It is based on the distance from the Empty level position to the Full level position (see below).

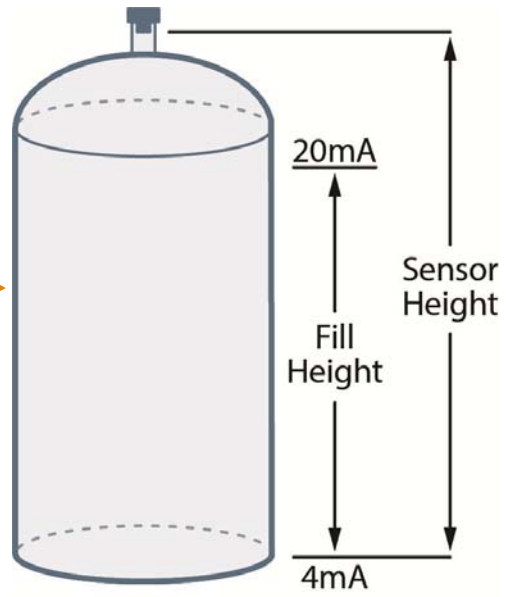
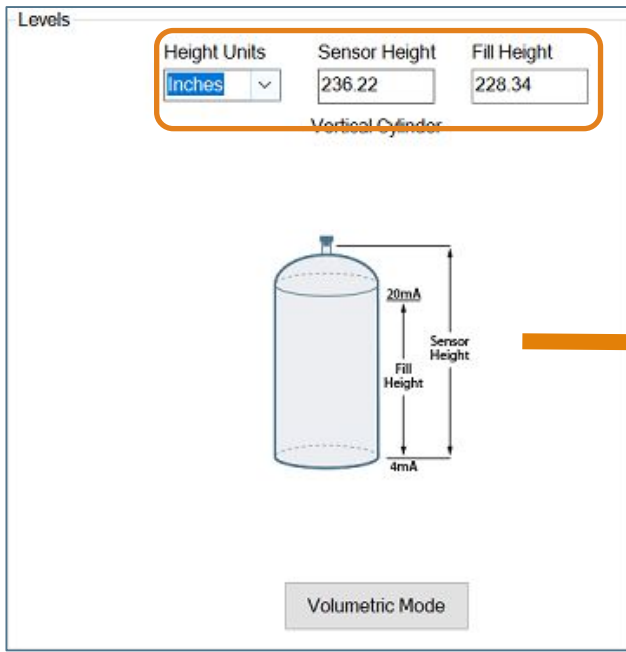

STEP 6 - TANK LEVEL CONFIRMATION

Verify the Height Units, Sensor Height & Fill-Height. All values were calculated and set in the previous Dimensional Entry window. Make any adjustments if required.

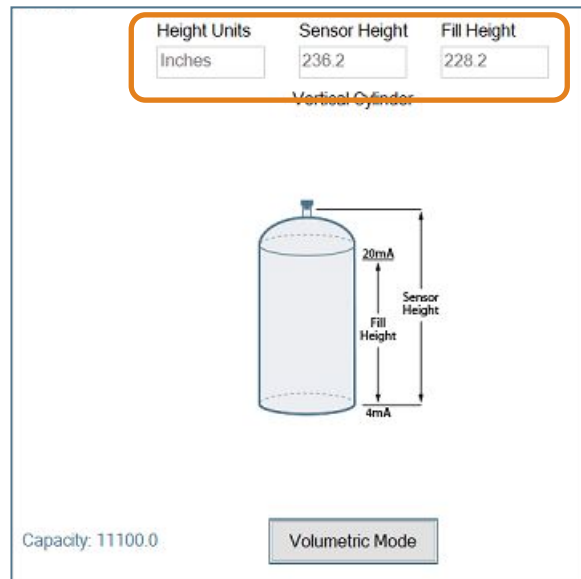
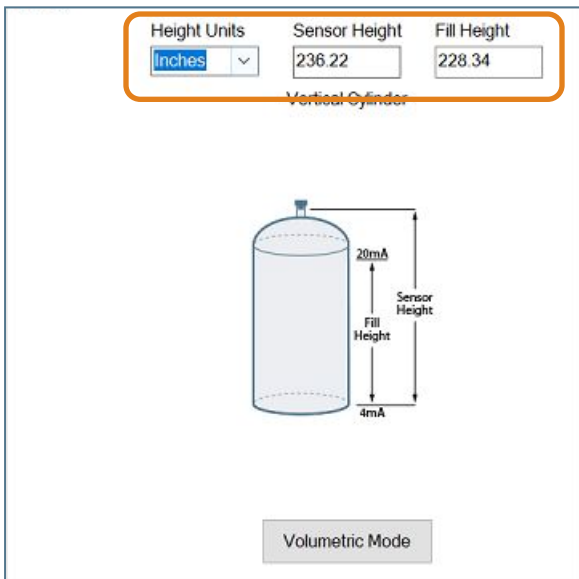

STEP 7 - WRITE TO UNIT

This WebCal[®]* operation uploads the configuration into the sensor, provides a custom wiring diagram specific to the signal output and/or relay configuration, and saves the configuration file to your hard drive.

Configuration Updates

Model Number UG06

Config

Loop Fail-Safe
Overfill (22 mA)

Output at Empty
4 mA at Bottom

Startup Condition
Empty

Part Type: UG06, Serial Number: 1001 Firmware: UG6p00
Description: Transmitter, 236.22" (6.0m) FW Rev. 1

Levels

Height Units Inches Sensor Height 236.22 Fill Height 228.34

Vertical Cylinder

20mA
Sensor Height
Fill Height
4mA

Volumetric Mode

Write to Unit
Wiring Diagram
Advanced
Factory Config
Clear Screen
Config File Name
Open Config File
Save Config File
Print Config File

Notes

Config #0

Help

* For complete information on the WebCal[®] software, please refer to the WebCal[®] manual located at flowline.com/webcal-software.

Before configuration can be completed:

- You must click the **Write to Unit** button to save the settings to the unit.
- Then, click **Wiring Diagram** for a hard copy of the sensor's settings.
- Finally, enter the file name under which you wish to save the configuration file and click **Save Config File**.

Configuration is now complete.

Disconnect the USB[®] Fob before continuing to the next step: Mounting the EchoPod[®].

CONFIGURING ECHOPOD® (DISPLAY)

TOP-LEVEL MENU

The sensor is configured with the three buttons on the sensor face (**UP**, **DOWN** and **OK**) and the sensor's LCD. To access the sensor's Top-level menu, simply hold down the OK button for five seconds. The display menu will automatically begin to scroll through the TOP-LEVEL MENU.

When the menu scrolls to an item you wish to configure, simply press the OK button to choose that item. The TOP-LEVEL MENU will continue to scroll through the following (**UNITS – TANK – dISPLY – OUTPUT – VALUES – RUN**), If you miss your selection, it will appear again shortly.

- To return to the TOP-LEVEL MENU, press OK when **EXIT** appears.
- To return to Operational Mode of the sensor, press OK when **RUN** appears in the TOP-LEVEL MENU.
- **Note:** To speed up the scrolling of the values on the display, hold down the OK button while holding down the UP or DOWN buttons.

STEP 1 - MEASURE THE TANK

Measuring the tank is one of the most important aspects in configuring the sensor. When measuring the tank, take into account the location of the sensor with respect to fittings, risers, dome tops and bottoms, and identify where the measurements are taken from the sensor. The HEIGHT and FILL-H settings determine the 4-20mA span and are always measured from the bottom of the tank up.

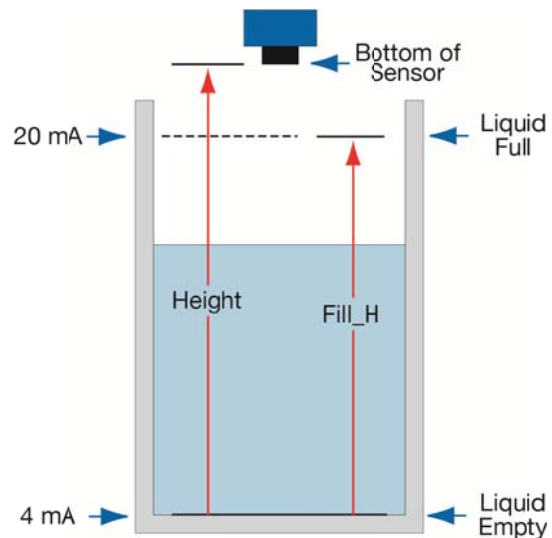

#2 - SETTING THE UNITS OF MEASUREMENT (UNITS)

The EchoPod® displays information in the following units: inches, feet, centimeters, meters or percentage. The value shown on the display represents the amount of liquid in the tank.

- 1) In TOP-LEVEL MENU mode, select **UNITS**.
- 2) Next, select **INCHES**, **FEET**, **CM**, **METERS** or **PERCNT**. **SAVED** will display.
- 3) Finally, select **EXIT** to return to the TOP-LEVEL MENU.

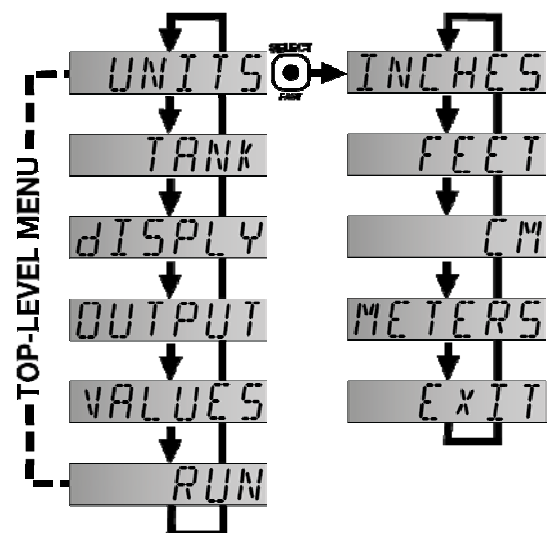

#3 - SETTING THE HEIGHT (SENSOR HEIGHT) & #4 - SETTING THE FILL-H (FILL-HEIGHT)

This setting customizes the reading for your installation.
Follow these instructions to set the height and fill height for your tank:

- 1) In TOP-LEVEL MENU mode, select **TANK**.
- 2) Select **HEIGHT**.
- 3) Use the UP and DOWN buttons, set the HEIGHT of your tank.
- 4) To enter the value, press and hold OK for 3 seconds and release. **SAVED** will display. HEIGHT is now set.
- 5) Select **FILL-H**.
- 6) Use the UP and DOWN buttons, set the HEIGHT of your tank.
- 7) To enter the value, press and hold OK for 3 seconds and release. **SAVED** will display. FILL-H is now set.
- 8) To enter the value, press and hold SELECT for 2 seconds and release. **SAVED** will display. FILL-H is now set.
- 9) Select **EXIT** to return to the TOP-LEVEL MENU.
- 10) Select **RUN** to return to Operational Mode.

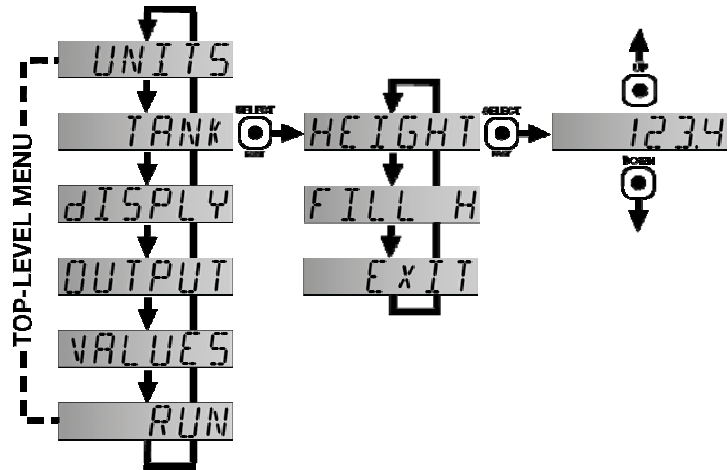

Note: The Height and Fill Height settings also determine the 4 to 20 mA current span. The Height setting determines the 4mA position and the Fill-H setting determines the 20 mA position.

#5 - HOW TO SELECT FAIL-SAFE CURRENT OUTPUT (LOST)

In the event the sensor does not receive an echo, the Fail-Safe Current Output or **LOST** setting can be set to output a current of **4mA**, **20mA**, **21mA**, **22mA** or **HOLD** (last known value). During fail-safe, the display will read **LOST**.

- 1) In TOP-LEVEL MENU mode, select **SAFE**.
- 2) Select **4mA**, **20mA**, **21mA**, **22mA** or **HOLD**. **SAVED** will display.
- 3) Select **EXIT** to return to the TOP-LEVEL MENU.

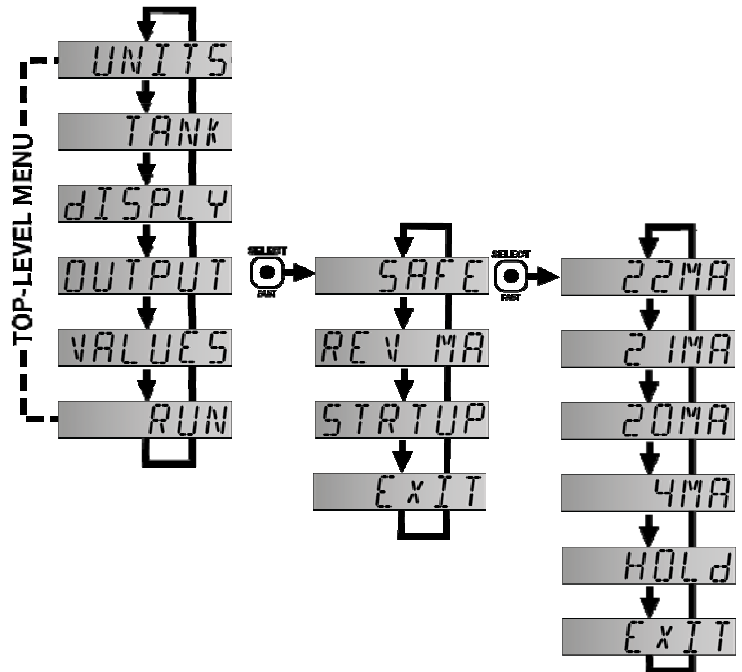

TROUBLESHOOTING

If you face any issues not addressed in this Quick Start, please refer to the EchoPod® Manual located on Flowline's website at www.flowline.com.

MOUNTING ECHOPOD®

The sensor should always be mounted perpendicular to the liquid surface. Insure that there are no restrictions or obstacles in the path of the acoustic signal. For further mounting information, please refer to the EchoPod® manual at www.flowline.com.

Installation in existing 3" fittings:

Use a LM52-2400 3" thread x 2" thread adapter or a LM52-2410 3" slip x 3" thread adapter.

Basic Tank Installation:

Use a 2" bulkhead fitting, such as the LM52-2890 bulkhead fitting.

Use a larger bulkhead fitting, such as the LM52-3890 with a reducer bushing such as the LM52-2400.

Use a flange with a 2" thread, such as the LM52-2850.

Weld a plastic 2" half coupling to the tank top.

Mounting in Riser:

Installations with tall, narrow risers can impede the acoustic signal. 2" diameter risers should be no taller than 5". Larger diameter risers should be no taller than 12". For best results, follow a 2:1 Height to Inner Diameter ratio (example: 8" High to 4" Inner Diameter).

Installation in open tanks and sumps:

Use Flowline's LM50-1001 side mount bracket.

Note: The Side Mount Bracket (LM50 series) is not designed for use with stand pipes or as a method to secure stand pipes. There are too few threads to properly hold the sensor and the stand pipe.



LM50-1001

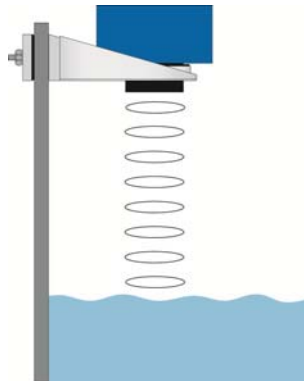

LM52-2400



LM52-2890



LM52-2850

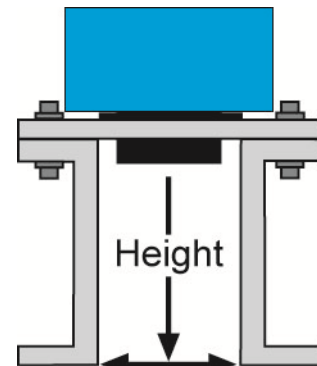

Inner Diameter
Mounting in Riser

IMPORTANT MOUNTING GUIDELINES

- 1) Never mount the sensor at an angle.
- 2) Liquid should never enter the dead band.
- 3) Mount at least 3" from the side wall.
- 4) Never mount the sensor in a vacuum.
- 5) Do not obstruct the sensor's beam width with objects underneath the sensor.
- 6) Avoid mounting in the center of a dome top tank.
- 7) In a cone bottom tank, position the sensor over the deepest part of the tank.
- 8) Avoid mounting in a riser where the sensor is recessed more than twice the diameter of the riser.

MOUNTING IN A STAND-PIPE

A stand-pipe may be used to dampen turbulence, separate surface foam from the point of measurement or increase performance in heavy vapor. When mounting the sensor in a stand-pipe, the minimum diameter of the pipe is 3". Larger diameter pipes can be used. The pipe should be attached with a coupling or tank adapter and reducer bushing. Avoid the use of multiple pipe fittings when possible. An ideal mount would be to select a 3" tank adapter (S x T or S x S) and connect the pipe to the inside slip and use a reducer bushing to attach the sensor (see example below).

The pipe length should run the measurement span and the bottom of the pipe should remain submerged at all times to prevent foam from entering the pipe. Cut the bottom end of the pipe at 45° and drill a 1/4" pressure equalization hole within the sensor's dead band. Locate the stand-pipe away from pump outlets and/or other sources of substantial turbulence which might cause the liquid in the pipe to oscillate.

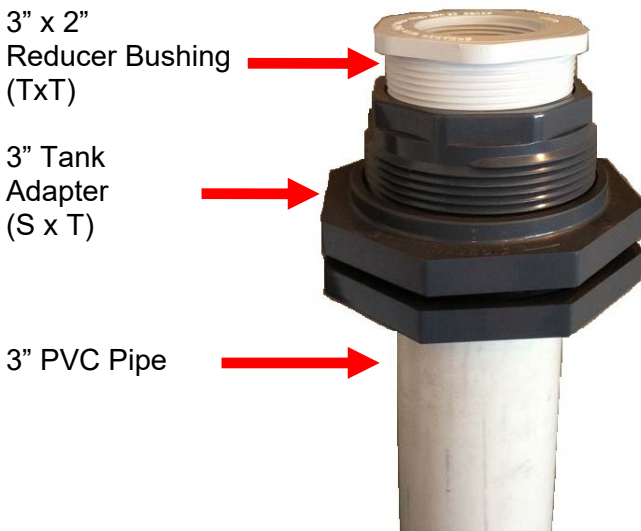

Stand-Pipe Example

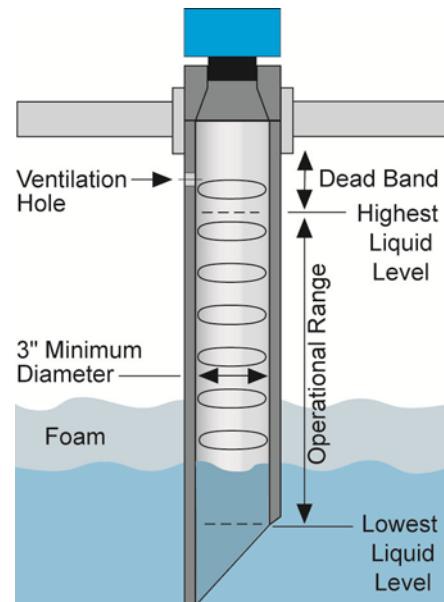

Stand-Pipe Mounting

WIRING THE ECHOPOD®

The following wiring diagram can be used for the 4-20 mA output of the EchoPod®.

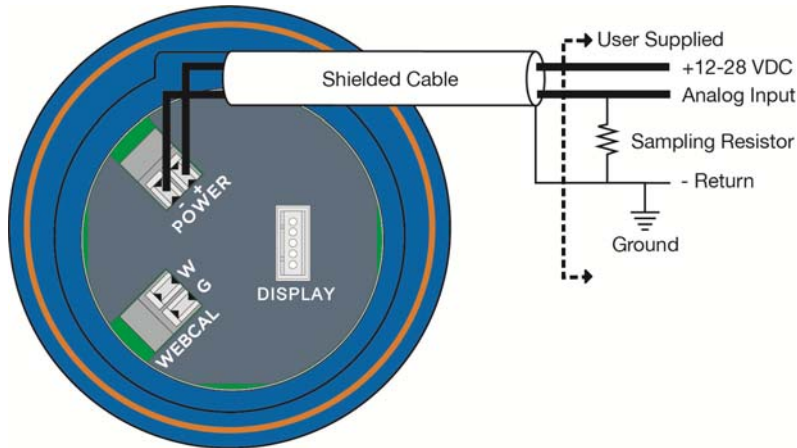

Notes on Safety

- Where personal safety or significant property damage can occur due to a spill, the installation must have a redundant backup safety system installed.
- Wiring should always be completed by a licensed electrician.
- The sensor must be chemically compatible with the application.
- Design a fail-safe system for possible sensor and/or power failure.
- Never use the sensor in classified hazardous environments.

Wiring to Common Devices

Wiring to Loop Display

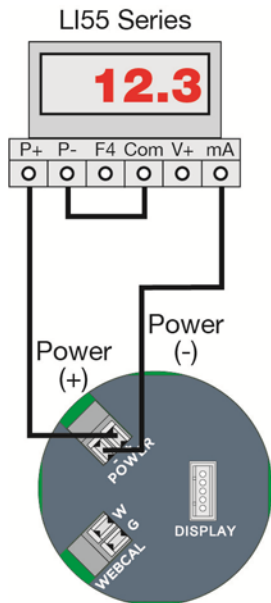

Wiring to Generic PLC

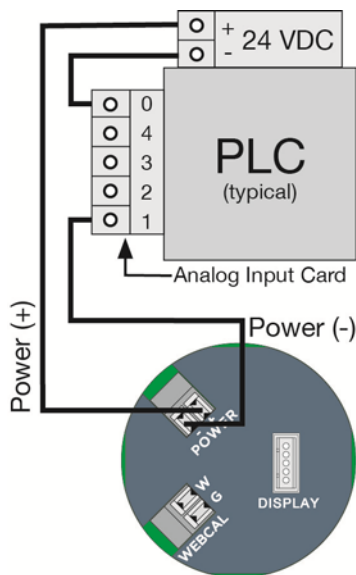

Wiring to DataView™ LI55 series

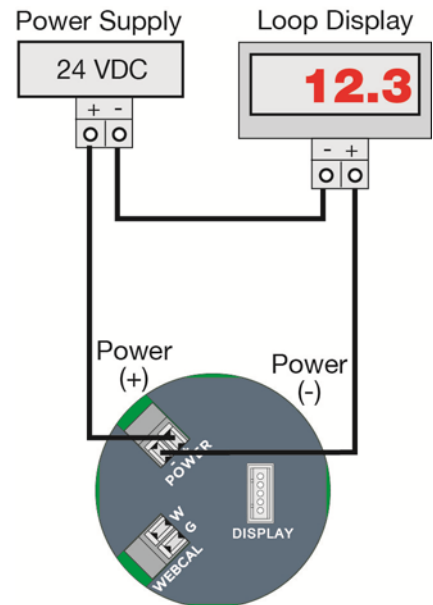

WARRANTY

Flowline warrants to the original purchaser of its products that such products will be free from defects in material and workmanship under normal use and service in accordance with instructions furnished by Flowline for a period of two years from the date of manufacture of such products. Flowline's obligation under this warranty is solely and exclusively limited to the repair or replacement, at Flowline's option, of the products or components, which Flowline's examination determines to its satisfaction to be defective in material or workmanship within the warranty period. Flowline must be notified pursuant to the instructions below of any claim under this warranty within thirty (30) days of any claimed lack of conformity of the product. Any product repaired under this warranty will be warranted only for the remainder of the original warranty period. Any product provided as a replacement under this warranty will be warranted for the full two years from the date of manufacture.

RETURNS

Products cannot be returned to Flowline without Flowline's prior authorization. To return a product that is thought to be defective, go to flowline.com, and submit a customer return (MRA) request form and follow the instructions therein. All warranty and non-warranty product returns to Flowline must be shipped prepaid and insured. Flowline will not be responsible for any products lost or damaged in shipment.

LIMITATIONS

This warranty does not apply to products which: 1) are beyond the warranty period or are products for which the original purchaser does not follow the warranty procedures outlined above; 2) have been subjected to electrical, mechanical or chemical damage due to improper, accidental or negligent use; 3) have been modified or altered; 4) anyone other than service personnel authorized by Flowline have attempted to repair; 5) have been involved in accidents or natural disasters; or 6) are damaged during return shipment to Flowline. Flowline reserves the right to unilaterally waive this warranty and dispose of any product returned to Flowline where: 1) there is evidence of a potentially hazardous material present with the product; or 2) the product has remained unclaimed at Flowline for more than 30 days after Flowline has dutifully requested disposition. This warranty contains the sole express warranty made by Flowline in connection with its products. ALL IMPLIED WARRANTIES, INCLUDING WITHOUT LIMITATION, THE WARRANTIES OF MERCHANTABILITY AND FITNESS FOR A PARTICULAR PURPOSE, ARE EXPRESSLY DISCLAIMED. The remedies of repair or replacement as stated above are the exclusive remedies for the breach of this warranty. IN NO EVENT SHALL FLOWLINE BE LIABLE FOR ANY INCIDENTAL OR CONSEQUENTIAL DAMAGES OF ANY KIND INCLUDING PERSONAL OR REAL PROPERTY OR FOR INJURY TO ANY PERSON. THIS WARRANTY CONSTITUTES THE FINAL, COMPLETE AND EXCLUSIVE STATEMENT OF WARRANTY TERMS AND NO PERSON IS AUTHORIZED TO MAKE ANY OTHER WARRANTIES OR REPRESENTATIONS ON BEHALF OF FLOWLINE. This warranty will be interpreted pursuant to the laws of the State of California. If any portion of this warranty is held to be invalid or unenforceable for any reason, such finding will not invalidate any other provision of this warranty.

For complete product documentation, video training, and technical support, go to flowline.com.
For phone support, call 562-598-3015 from 8am to 5pm PST, Mon - Fri.
(Please make sure you have the Part and Serial number available.)