

Signet Conductivity/Resistivity Tool



2850.101-X

The Signet Conductivity/Resistivity tool is available for certification or validation of electronics that are independent of the electrode. Because there are no available liquid standards for calibration in low conductivity and resistivity applications, the tool is ideal for various installations. The tool is built to conform to the ASTM D 1125-95 Standard (Standard Test Methods for Electrical Conductivity and Resistivity of Water), which is also commonly used for USP 24 applications.

The Signet Conductivity/Resistivity tool simulates within $\pm 0.1\%$ precision (accuracy), various values: 1.0 μS , 2.5 μS , 10.0 μS , 10.0 $\text{M}\Omega$, 18.2 $\text{M}\Omega$. The tool is also temperature compensated to 25 °C and enables the user to accurately validate or certify the electronics.

The 2850.101-X simulators are used with the Model 9900 and Model 2850 electronics by simply plugging into the same terminals as the sensor cables.

Features

- Available in five different values
- Compatible with 3-2850 electronics when used with the 8900 Multi-Parameter Controller, 9900 or 9950 Transmitter or as a stand-alone 4 to 20 mA output
- Verifies electronics independent of electrode
- NIST traceable units
- Temperature compensated to 25 °C
- All units ship with NIST traceable certificates

S ³ L Input	4 to 20 mA Output
Signet Instrument with 0486 Profibus and Customer Supplied Programmable Logic Controller or Programmable Automation Controller - 8900 - 9900 - 9950	Customer Supplied Chart Recorder, Programmable Logic Controller, or Programmable Automation Controller
Signet Sensor Electronics - 2850-51 - 2850-61 - 2850-63 - 9900.394 (9900 only)	Signet Sensor Electronics - 2850-52 - 2850-62

Signet 2580.101-X Certification Tool



All sold separately

Wiring

3-2850.101-X

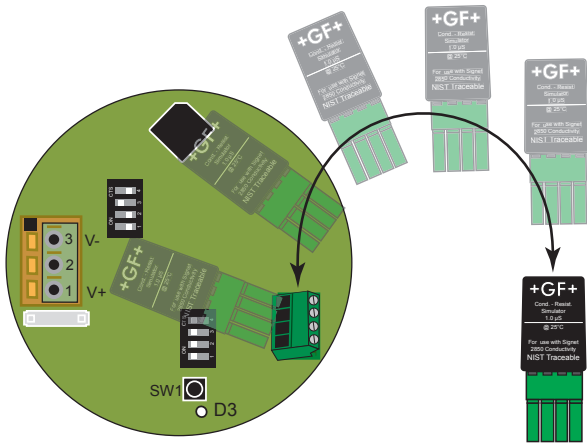

3-9900

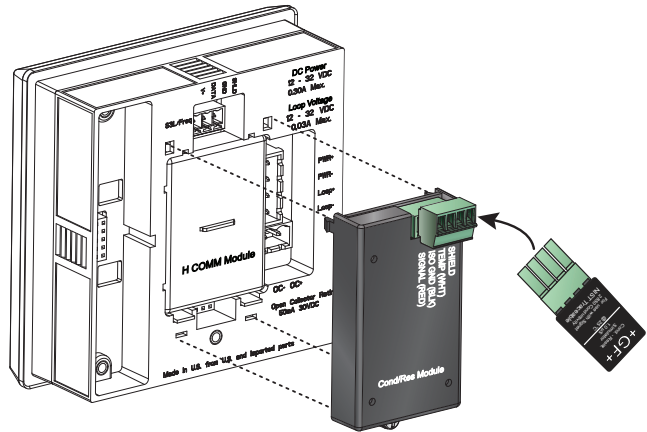

3-9950

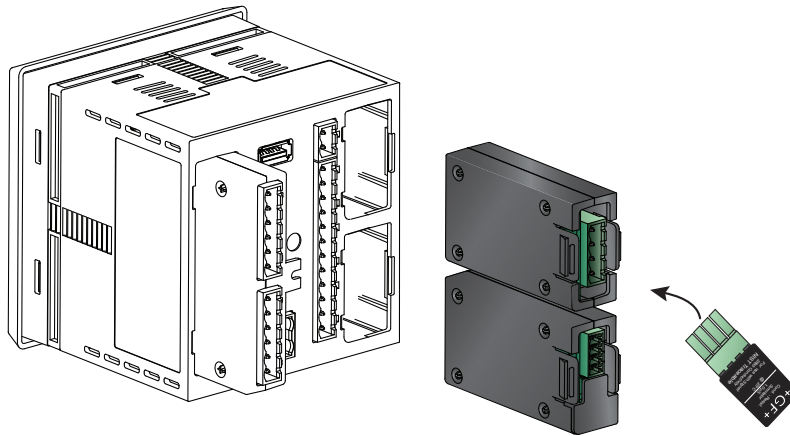

Ordering Information

Mfr. Part No.	Code	Description
3-2850.101-1	159 001 392	Plug-in NIST Traceable Tool, 1.0 μ S simulated for Signet Models 2850-5X, 2850-6X
3-2850.101-2	159 001 393	Plug-in NIST Traceable Tool, 2.5 μ S simulated for Signet Models 2850-5X, 2850-6X
3-2850.101-3	159 001 394	Plug-in NIST Traceable Tool, 10.0 μ S simulated for Signet Models 2850-5X, 2850-6X
3-2850.101-4	159 001 395	Plug-in NIST Traceable Tool, 18.2 Ω simulated for Signet Models 2850-5X, 2850-6X
3-2850.101-5	159 001 396	Plug-in NIST Traceable Tool, 10.0 Ω simulated for Signet Models 2850-5X, 2850-6X

3-2830.099 Rev G (09/20)

© Georg Fischer Signet LLC

3401 Aero Jet Avenue, El Monte, CA 91731-2882 U.S.A. • Tel. (626) 571-2770 • Fax (626) 573-2057 • www.gfsignet.com • e-mail: signet.ps@georgfischer.com

Specifications subject to change without notice. All rights reserved. All corporate names and trademarks stated herein are the property of their respective companies.