

# Submersible Pumps & Float Switches



2XH5, 2X11

- **304 Stainless Steel Casing, Motor Housing, Shaft and Hardware**
- **Cast Iron Impeller, Top and Pump End**
- **Light Weight Slim Design**
- **Oil Lubricated Seals, Nitrile O-Rings**
- **Lower Seal – Silicon-Carbide, Viton®**
- **Upper Seal – Carbon Ceramic, Viton®**
- **Thermal Overload Protected**
- **2" NPT Discharge**
- **1/2 to 1 Horsepower**
- **Solids Handling and Dirty Water Design**

Optional Piggyback Float Switch 55-931



Slim-design, light weight CSA listed submersibles feature top discharge as well as cast-iron impellers, 304 stainless steel casing, motor housing, shaft and hardware. Pump motor is thermal overload protected. An optional piggyback mercury-free float switch is available. Float Switches: The mercury free liquid level control has a piggyback plug molded to the cord allowing the pump motor to plug into the cord and then plug the entire assembly into a standard grounded outlet.

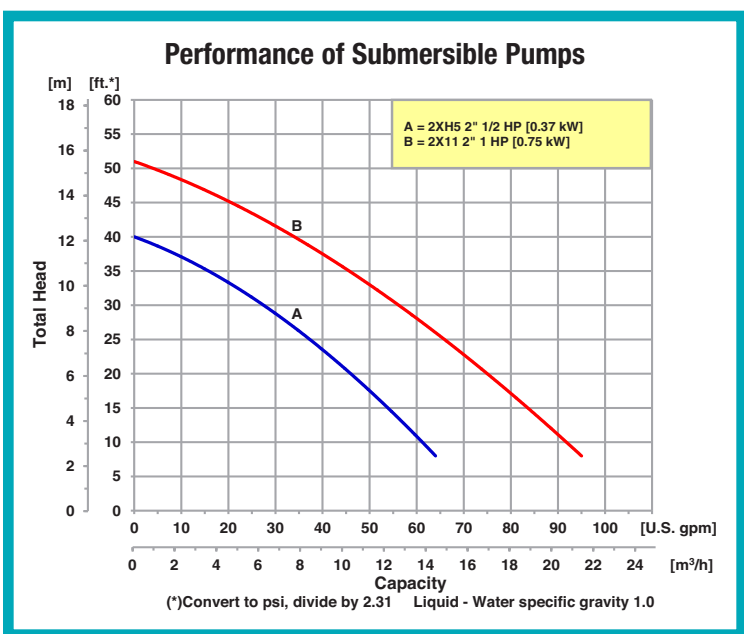

400 Spring Street • Royersford, PA 19468 USA

**www.amtpump.com • 888-amt-pump (268-7867)**

For use with nonflammable liquids compatible with pump component materials. Viton® is registered trademarks of E. I. DuPont.



# Submersible Pumps & Float Switches

## Pump Dimensional & Specification Data

Model	Description/Type	Basic Construction	DIS*	HP	VAC	Full Load Amps	A	B	C	D Cable Length	E** Suction Strainer	W	H	Ship Wt. (Lbs.)
2XH5	Submersible Pump	Stainless Steel/ Cast Iron	2	1/2	115	6	11.1 [28.2]	3.3 [8.4]	1.4 [3.5]	30 [9.1 M]	0.39/[0.9] x 0.24/[0.6] Slots on 0.31/[0.7] Staggered Centers	6.6 [16.7]	14.5 [36.8]	31
2X11	Submersible Pump	Stainless Steel/ Cast Iron	2	1	115	10	13.7 [34.8]	3.8 [9.6]	1.6 [4.1]	50 [15.2 M]	0.25/[0.6] x 0.38/[0.9] Slots on 0.50 [1.2] Staggered Centers	7.5 [19.0]	17.1 [43.4]	50

(\*) Standard NPT (Female) pipe thread.

(\*\*) Strainer defines maximum solids handled.

NOTE: Dimensions are in inches (centimeters) and have a tolerance of  $\pm 1/4"$ .

NOTE: Electric supply for ALL motors must be within  $\pm 10\%$  of nameplate voltage rating (e.g 230V  $\pm 10\%$ =207 to 253).

(S) Minimum Liquid Height

## Submersible Pump Standard Features

- Light Weight Slim Design
- Motors Protected by Overload or Thermal Breaker
- Lower Seal – Silicon-Carbide, Viton®
- Upper Seal – Carbon Ceramic, Viton®
- Oil Lubricated Seals
- Cast Iron Impeller, Top & Pump End
- 304 Stainless Steel Casing, Motor Housing, Shaft and Hardware
- Long Power Cables
  - 1/2 HP is 30 Feet in Length
  - 1 HP is 50 Feet in Length
- Optional Piggyback Mercury-free Float Switches
- Nitrile O-rings
- Max Temperature 104° F
- QSP – Quick Ship Pumps

Model	Curve	Description/Type	HP	NPT Port Size	Basic Construction
2XH5	A	Submersible Pump	1/2	2"	Stainless Steel/Cast Iron
2X11	B	Submersible Pump	1	2"	Stainless Steel/Cast Iron

Model	Description	Ship Wt. (Lbs.)
55-931	Float Switches - Electrical Rating for 115/15 Amps with 30 Ft. 14 GA Cord	4
55-951	Float Switches - Electrical Rating for 115/15 Amps with 50 Ft. 14 GA Cord	5

## Float Switch Standard Features

- Mercury-Free
- No Wiring
- Adjustable Clamp
- Corrosion Resistant
- Proven Reliability
- Omni Directional
- Variable Pumping Range
- Easily Installed

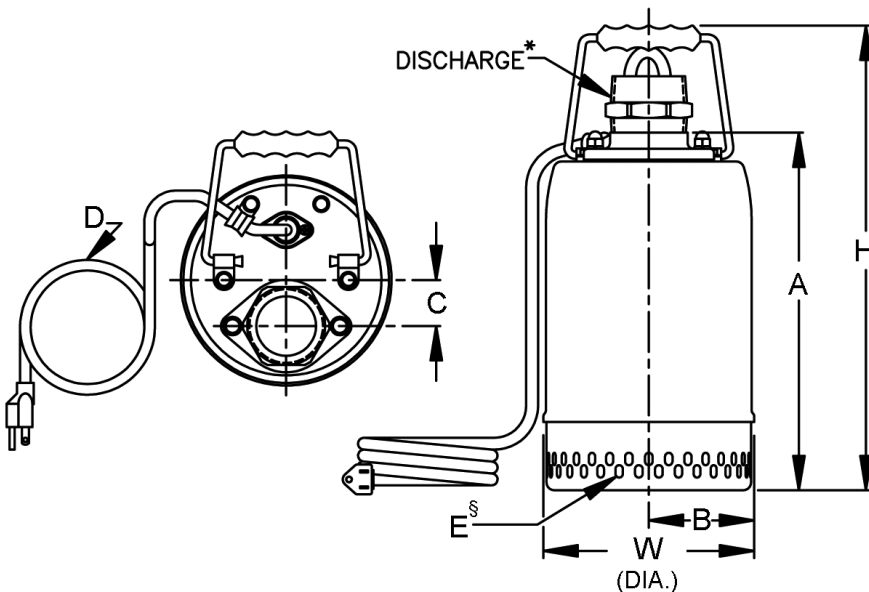

Manufacturer of AMT & IPT Pumps

400 Spring Street • Royersford, PA 19468 USA

[www.amtpump.com](http://www.amtpump.com) • 888-amt-pump (268-7867)

The Gorman-Rupp Company reserves the right to discontinue any model or change specifications at any time without incurring any obligation.  
©2012 American Machine and Tool Company. All rights reserved.



1219