

Industrial/Commercial Sump Pumps

- **Stainless Steel, Bronze and Cast Iron Construction**
- **Stainless Steel Shaft & Float**
- **Carbon Bearings**
- **29" to 44" Column Height**
- **1-1/2" or 2" NPT Discharge**
- **Maximum Head 30 Ft.**
- **Maximum Flow 103 GPM**
- **Semi-Open, Clog Resistant Impellers**
- **Solids Handling and Dirty Water Design**
- **Available with Totally Enclosed Fan Cooled (TEFC) 1/3, 1/2 and 3/4 HP 115 VAC, Single Phase Motors**



Stainless Steel TEFC Model Sump Pump

The AMT line of Industrial/Commercial Sump pumps is designed for heavy duty commercial applications, as well as residential use where a combination of durability and high performance is required. AMT Sump pumps are available in stainless steel, bronze and cast iron constructions with TEFC motors in 1/3 through 3/4 HP for proper pump selection in most applications. All models include stainless steel shaft, screen and float. All motors are fitted with automatic switch and an 8 foot 16/3 115 VAC line cord. Pumps require minimum sump pit of 14" diameter and 24" depth. Pumps are designed to handle liquids with solids contents or dissolved solids and debris.

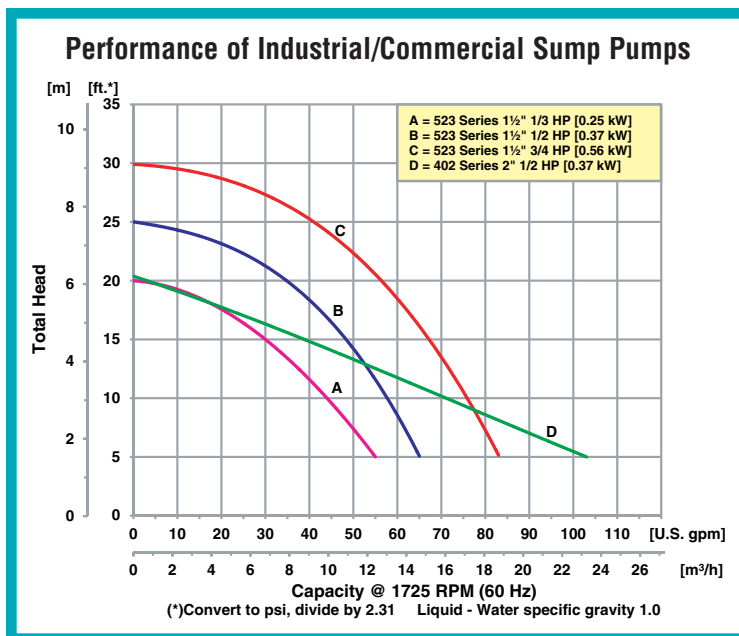

400 Spring Street • Royersford, PA 19468 USA

www.amtpump.com • 888-amt-pump (268-7867)

For use with nonflammable liquids compatible with pump component materials. Viton® is registered trademarks of E. I. DuPont.

Pump Dimensional & Specification Data

Model #	Curve	DIS*	HP	PH	ENC	Voltage @ 60 Hz	Full Load Amps	Motor Frame	A	B	C	D	E	F	G	J	W	H**	‡ Ship Wt. (Lbs.)
5239	A	1-1/2	1/3	1	TEFC	115	6	56C	8.5 [21.7]	4.6 [11.8]	4.2 [10.9]	29.9 [75.9]	3.5 [8.9]	3.2 [8.1]	50.7 [128.8]	16.7 [42.5]	11.0 [28.0]	38.4 [97.7]	42
523C	B	1-1/2	1/2	1	TEFC	115	9	56C	9.0 [22.9]	4.6 [11.8]	4.2 [10.9]	29.9 [75.9]	3.5 [8.9]	3.2 [8.1]	50.7 [128.8]	16.7 [42.5]	11.0 [28.0]	39.9 [98.8]	43
523D									9.0 [22.9]	4.6 [11.8]	4.2 [10.9]	41.9 [106.4]	3.5 [8.9]	3.2 [8.1]	62.7 [159.3]	28.7 [73.0]	11.0 [28.0]	50.9 [129.3]	45
523F	C	1-1/2	3/4	1	TEFC	115	12	56C	9.2 [23.4]	4.6 [11.8]	4.2 [10.9]	29.9 [75.9]	3.5 [8.9]	3.2 [8.1]	50.7 [128.8]	16.7 [42.5]	11.0 [28.0]	39.1 [99.4]	47
4020+	D	2	1/2	1	TEFC	115	9	56C	9.0 [22.9]	5.5 [14.0]	5.0 [12.8]	30.9 [78.5]	4.5 [11.5]	3.4 [8.8]	51.7 [131.4]	17.7 [45.1]	12.6 [32.2]	39.9 [101.4]	51
4021+									9.0 [22.9]	5.5 [14.0]	5.0 [12.8]	30.9 [78.5]	4.5 [11.5]	3.4 [8.8]	51.7 [131.4]	17.7 [45.1]	12.6 [32.2]	39.9 [101.4]	50
4022+									9.0 [22.9]	5.5 [14.0]	5.0 [12.8]	42.9 [109.0]	4.5 [11.5]	3.4 [8.8]	63.7 [161.9]	17.7 [45.1]	12.6 [32.2]	51.9 [131.9]	54

(*) Standard NPT (female) pipe thread.

NOTE: Check Price Book for Specific Pump Construction/Material Availability.

(**) This dimension may vary due to motor manufacturer's specifications.

NOTE: All dimensions are in inches (centimeters) and have a tolerance of $\pm 1/8"$

NOTE: Electric Supply for ALL motors must be within $\pm 10\%$ of nameplate voltage (Ex: 230V = 203 to 253)

(+) Handles up to 3/4" Solids

‡ When Ordering Add the Correct-9? Suffix to Model Number Indicating Material Selection (Ex: 5239-95)

XCI (-95) = Cast Iron Construction with Stainless Steel Impeller

XB (-97) = Cast Bronze Construction with Stainless Steel Impeller (Refer to Pricebook for Available Models)

XSS (-98) = Stainless Steel Construction with Stainless Steel Impeller (Refer to Pricebook for Available Models)

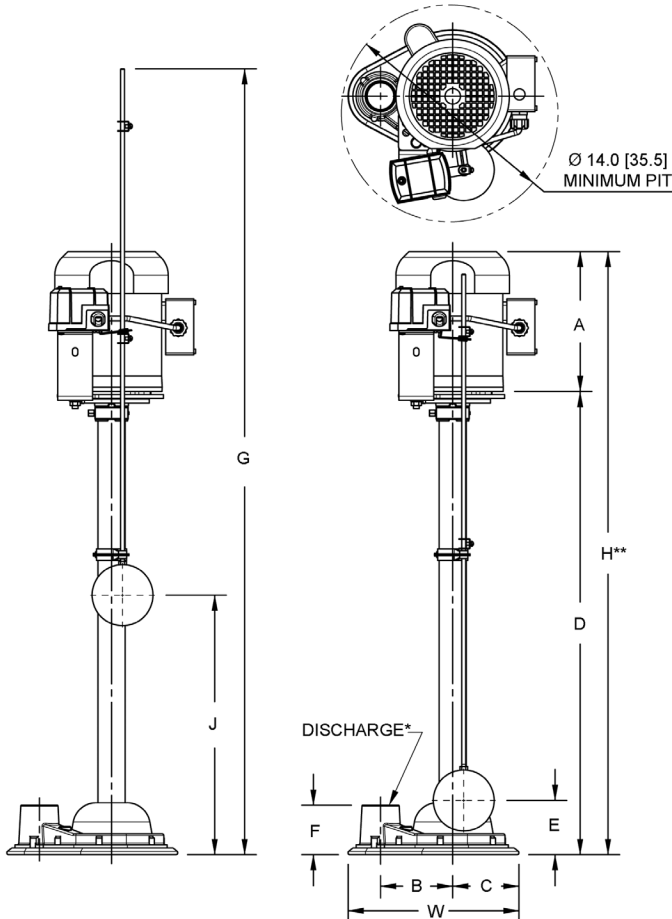

Standard Features

- Stainless Steel Screen and Float
- Semi-Open, Clog Resistant Impellers
- 1/3, 1/2 or 3/4 HP TEFC 115 VAC Single Phase 56C Frame Motors
- 8 Ft. 16/3 115 VAC Line Cord
- Maximum Head 30 ft.
- Maximum Flow 103 GPM
- Stainless Steel Shaft
- Carbon Bearings
- 29" to 44" Column Height
- Maximum Temperature 200° F
- Solids Handling Design up to 3/4" Diameter (25% Maximum Solids)
- QSP – Quick Ship Pumps