

# SELF-PRIMING TRASH PUMPS

## SPT/SXT SERIES

## SPU/SXU SERIES

FRAME MOUNTED PUMP



QUALITY | COMMITMENT | ADAPTABILITY



HIGH ON **PERFORMANCE**  
GREAT ON **RELIABILITY**

# SELF-PRIMING TRASH PUMPS

## Design Features

Rotech Pumps presents a range of Self-Priming Centrifugal. These pumps are economical & offer trouble-free operation in handling solids laden liquids and slurries. Pump features a large volume design which allows them to re-prime automatically in a completely open system without the need of suction or discharge check valves. And this is workable with the pump only partially filled with liquid and completely dry suction line. Pump can handle up to 3" spherical solids, depending on pump models. In case pump shafts or bearings need service, the entire rotating assembly can be removed without disturbing pump casing or pipelines.

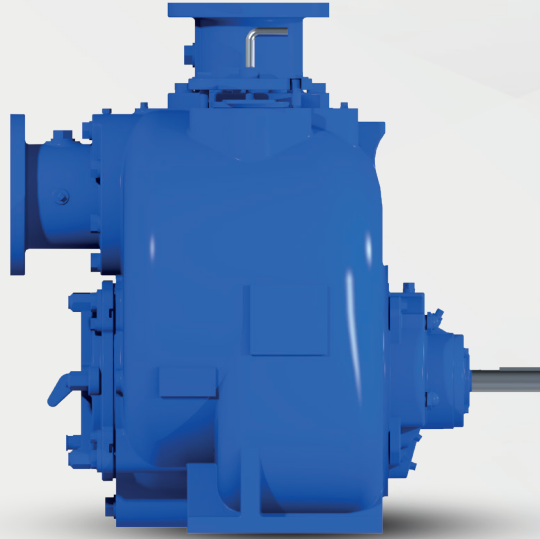

### Key Advantages

- Superior Solid Handling
- Self Priming
- Easy Maintenance

### Material Options

Cast Iron, ADI, CS, 304SS, 316SS, CD4MCUN, Alloy20, Hastelloy-B & C

### Available Discharge Sizes

2", 3", 4", 6", 8", 10" & 12"

### Sealing Option

Available in Tc/Tc/Viton mechanical seal to handle abrasive liquid and sewage, Industrial waste etc.. Custom designed seal to handle corrosive chemical like Keton, Xylene, Tolulene

### Trash Design

Trash cover for easy maintenance without disturbing pipeline

### Dual Bearing Protection

An atmospheric barrier along with two lip seals provide additional protection of the pump bearings. This unique design also allows for quick and easy external monitoring of the bearing cavity (not available on 2" models).

### Removable Rotating Assembly

The entire rotating assembly can be removed without disturbing the pump volute or piping. Pusher bolt holes are provided to assist with removal. This allows for quick and easy installation of a spare rotating assembly, resulting in less downtime.

### Drive Options

Can be coupled with standard NEMA & IEC motors. No special motor required. Also can be coupled with diesel engine.

### Coupling Options

- Direct Coupled
- Belt - Pulley Driven

### Impeller Options

Two-vane, ductile iron, semi-open solids-handling impeller handles up to 75 mm (3") diameter solids, depending on pump model. Pump out vanes on the impeller shroud reduce foreign material buildup behind the impeller and reduce pressure on seal and bearings.

# HYDRAULIC PERFORMANCE COVERAGE

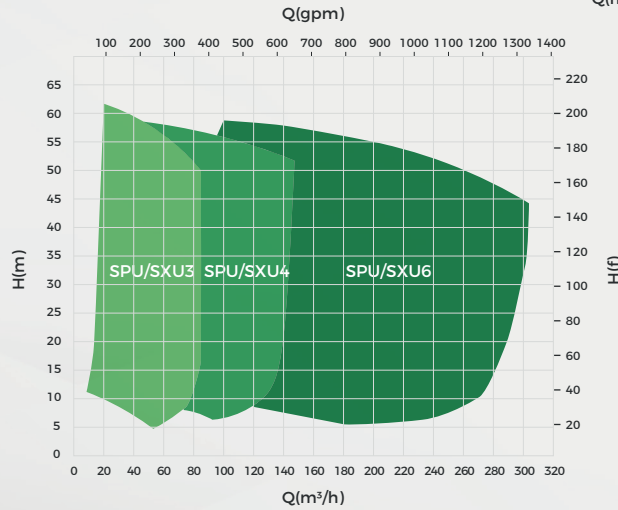
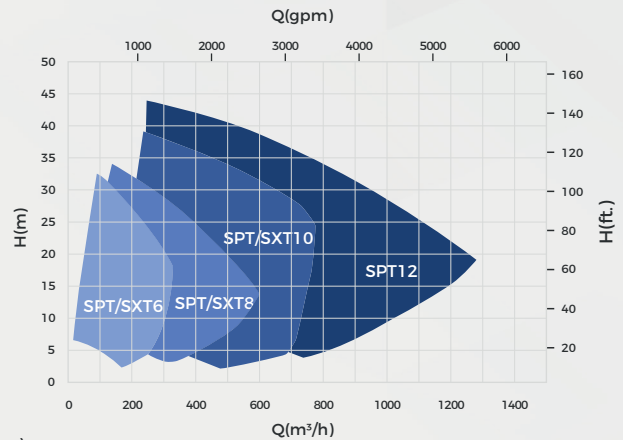
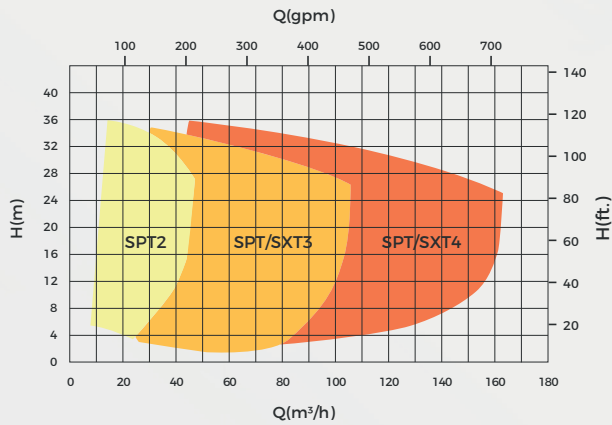
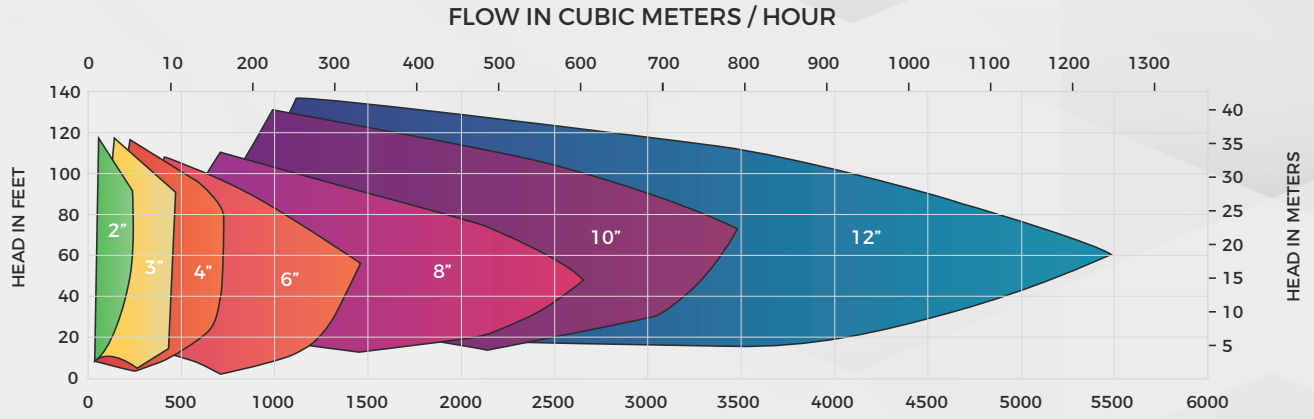

## SPT/SXT & SPU/SXU FLOW IN GPM

| PUMP SIZE  | ST2"       | SPT/SXT 3" | SPT/SXT 4" | SPT/SXT 6" | SPT/SXT 8" | SPT/SXT 10" | SPT 12"    |
|------------|------------|------------|------------|------------|------------|-------------|------------|
| RPM RANGE  | 650 - 2900 | 650 - 2150 | 650 - 1950 | 650 - 1550 | 650 - 1350 | 650 - 1450  | 650 - 1450 |
| MAX SOLIDS | 1.75"      | 2.5"       | 3"         | 3"         | 3"         | 3"          | 3"         |

| PUMP SIZE  | SPU/SXU 3" | SPU/SXU 4" | SPU/SXU 6" |
|------------|------------|------------|------------|
| RPM RANGE  | 650 - 2900 | 650 - 2150 | 650 - 1950 |
| MAX SOLIDS | 1.75"      | 1.75"      | 1.75"      |

# PUMP DESIGN FEATURES / ADVANTAGES

## Casing

- Full line of corrosive resistant materials
- Self venting, centerline mounted discharge flange
- Various Connection options : Threaded, Flanged
- Increased casing thickness for extended casing life.

## Flapper Dis

- Automatically closes once pump is stopped to avoid losing priming

## Wear Plate

## Impeller

- Semi-open impeller
- Designed to pump solids up to 3"

## Trash Cover

- For easy maintenance without disturbing piping

## Pressure Relief Valve

## DELIVERY

Pumps / parts are strategically inventoried at various locations in North America, Asia for rush delivery in various material options.

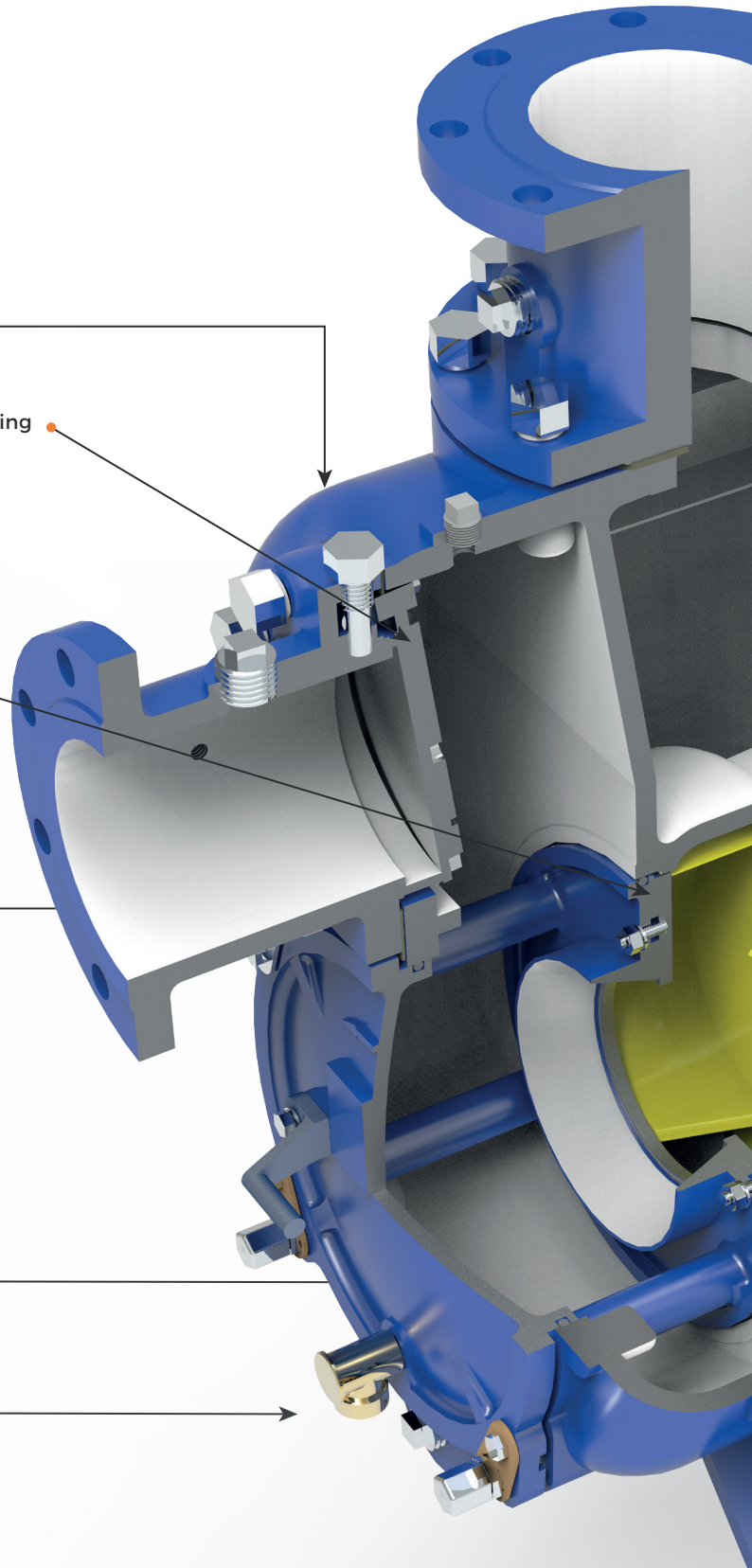

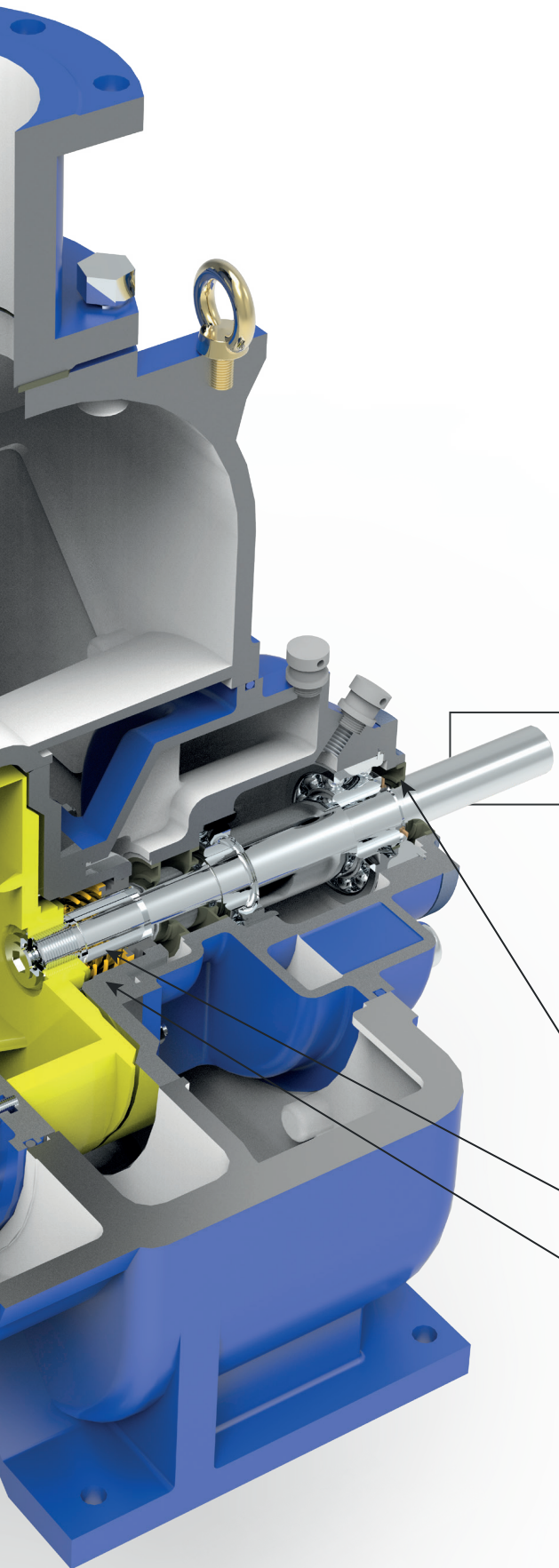

**Thrust Bearing**

- Heavy duty double row standard
- Optional duplex angular contact thrust bearing

**Shaft**

- Rigid heavy duty design for minimum shaft deflection at seal area and increased Reliability

**Oil Sea**

**Sleeve**

**Seal Housing**

**PUMP SELECTOR PROGRAM**

Helps to select & size the pumps for various applications. Please contact us for more details.

## SPT/SXT (2" - 10" Dimensions)

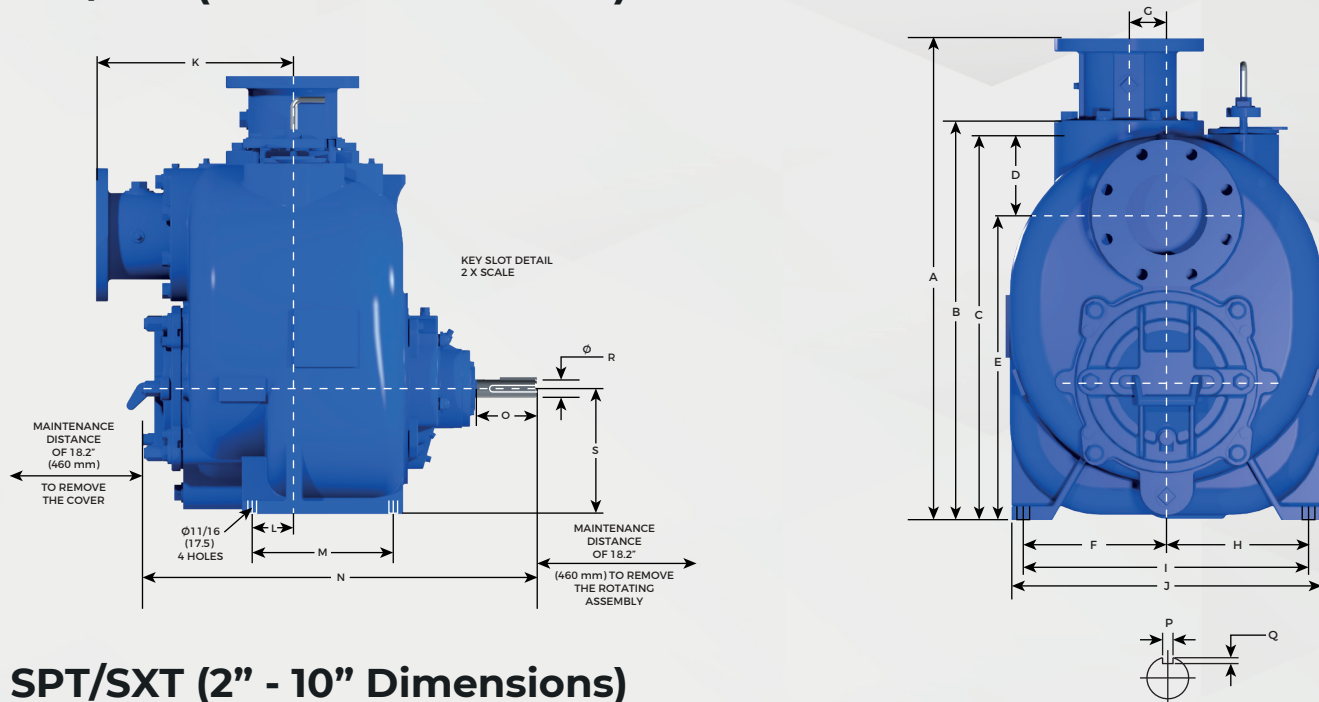

## SPT/SXT (2" - 10" Dimensions)

| SPT/SXT | A   | B     | C     | D    | E     | F     | G    | H     | I     | J     | K              | L    | M    | N     | O    | P    | Q    | R    | S     |
|---------|---|-------|-------|------|-------|-------|------|-------|-------|-------|----------------|------|------|-------|------|------|------|------|-------|
| 2"      | 20.62   | 16.92 | 15.55 | 3.04 | 12.51 | 5.53  | 2.75 | 5.53  | 11.06 | 12.14 | 9.21           | 2.12 | 6.42 | 21.53 | 4.05 | 0.38 | 0.21 | 1.5  | 5.96  |
| 3"      | 27.50   | 22.25 | 21    | 4    | 17    | 7.75  | 2.75 | 7.75  | 15.5  | 17    | 11.6/<br>11.56 | 3    | 9    | 28.57 | 4    | 0.38 | 0.21 | 1.5  | 7.5   |
| 4"      | 29.25   | 25.75 | 24.38 | 4.88 | 19.5  | 9     | 2.75 | 9     | 18    | 19.75 | 12.5           | 3.06 | 11   | 32    | 5    | 0.38 | 0.21 | 1.5  | 8.75  |
| 6"      | 35.31   | 29.88 | 28.25 | 5.87 | 22.38 | 10.38 | 2.75 | 10.38 | 20.75 | 22.75 | 16             | 3.06 | 11   | 35.5  | 5    | 0.38 | 0.21 | 1.5  | 10.13 |
| 8"      | 42.06   | 37.81 | 36    | 7.5  | 28.5  | 12.5  | 0    | 12.5  | 25    | 27.75 | 16.25          | 4    | 12   | 40.28 | 6.69 | 0.38 | 0.21 | 1.75 | 13    |
| 10"     | 41.25   | 41.25 | N/A   | N/A  | 25.19 | 12.5  | 0    | 12.5  | 25    | 27.75 | 28             | 4    | 12   | 48.71 | 4.81 | 0.38 | 0.21 | 1.75 | 14    |
| 12"     | For 12 inch Pump size, please contact us for dimensional details. |       |       |      |       |       |      |       |       |       |                |      |      |       |      |      |      |      |       |

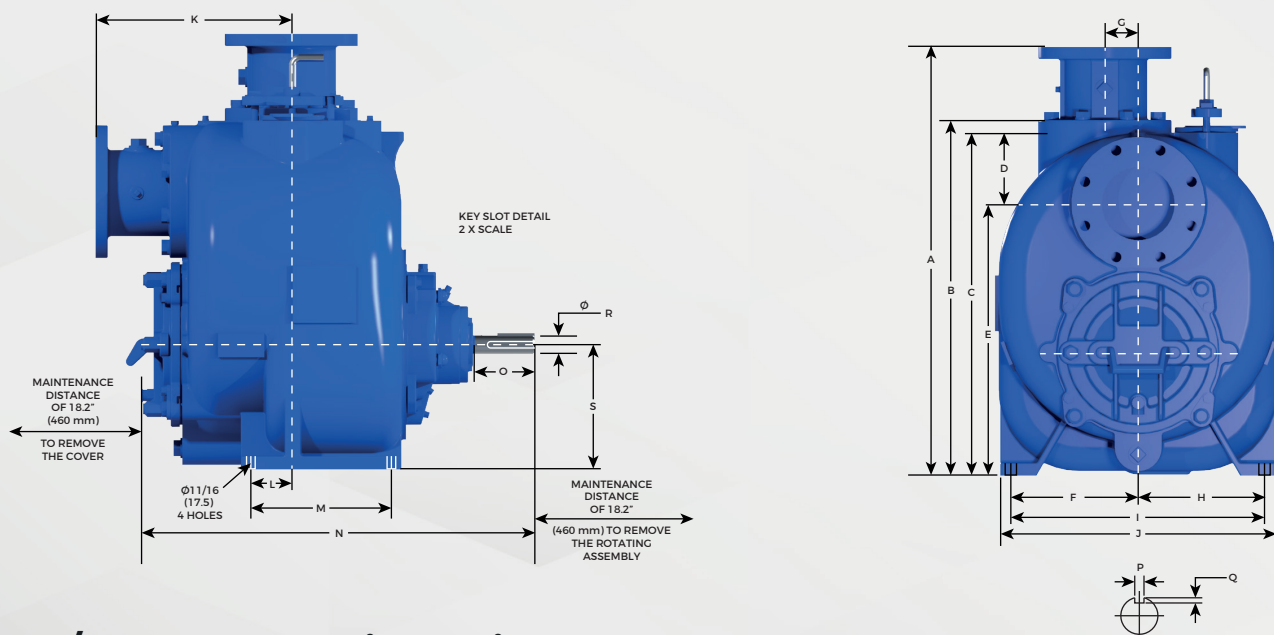

## SPU/SXU (3" - 6" Dimensions)

| SPU/SXU | A     | B     | C     | D    | E     | F     | G    | H     | I     | J  | K     | L    | M  | N     | O    | P    | Q    | R    | S     |
|---------|-------|-------|-------|------|-------|-------|------|-------|-------|----|-------|------|----|-------|------|------|------|------|-------|
| 3"      | 27    | 22.23 | N/A   | 5.23 | 17    | 7.75  | 2.75 | 7.75  | 15.5  | 17 | 11.5  | 3    | 9  | 26.25 | 4.06 | 0.38 | 0.19 | 1.5  | 7.5   |
| 4"      | 29.68 | 26.25 | 24.87 | 4.87 | 20    | 9     | 2.75 | 9     | 18    | 20 | 12.31 | 3.81 | 11 | 29.59 | 4.97 | 0.38 | 0.19 | 1.5  | 8.75  |
| 6"      | 35.32 | 29.88 | 28.25 | 7.51 | 22.38 | 10.38 | 2.75 | 10.38 | 20.76 | 23 | 16    | 3.06 | 11 | 33.25 | 4.97 | 0.38 | 0.19 | 1.75 | 10.12 |

## Parts Interchangeability of SXT vs. SPT

| Size | Common Parts  | Interchangeable                                      | Not Interchangeable   |
|------|---|--|---|
| 3"   | Impeller, Seal Assembly, Outboard & Inboard Bearings, Seal Plate, Wear Plate Assembly | Rotating Assembly, and Pump footprints are identical | Volute Casing, Back Coverplate Assembly, Impeller Shaft                                 |
| 4"   | Impeller, Seal Assembly, Seal Plate, Wear Plate Assembly                              | Rotating Assembly, and pump footprints are identical | Volute Casing, Back Coverplate Assembly, Bearings, Impeller Shaft                       |
| 6"   | Wear Plate Assembly   | Rotating Assembly, and pump footprints are identical | Volute Casing, Back Coverplate Assembly, Impeller, Seal Plate, Bearings, Impeller Shaft |
| 8"   | Impeller, Seal Assembly, Outboard & Inboard Bearings, Seal Plate, Wear Plate          | Rotating Assembly, and pump footprints are identical | Volute Casing, Back Coverplate Assembly, Impeller Shaft                                 |
| 10"  | Impeller, Outboard & Inboard Bearings   | Rotating Assembly, and pump footprints are identical | Volute Casing, Seal Plate, Impeller Shaft   |

## Difference between SXT vs. SPT

|  | SXT   | SPT   |
|--|---|---|
| ① Impeller to Waer Plat clearance Adjustment | External shimless and indexable adjustment via unique locking collar design       | Adjustment via insertion of shims between rotating assembly and volute casing |
| ② Coverplate                                 | Four point attachment with additional O-ring between vacuum and pressure chambers | Two point attachment with single O-ring at the outer bore                     |
| ③ Coverplate Removal                         | Pusher bolt holes and easy grip handle provided                                   | Cover can be pried from volute with pry bars                                  |
| ④ Rotating Assembly                          | Interchangeable with T Series® Classic Rotating Assembly                          | Interchangeable with Super T Series® Rotating Assembly                        |
| ⑤ Atmospheric Isolation                      | Double lip seal with atmospheric barrier allows for external monitoring           | Single lip seal with vented pipe plug   |
| ⑥ Seal Oil Monitoring                        | Via clear sight gauge   | Via removal of seal chamber vent plug   |
| ⑦ Rotating Assembly Removal                  | Eased by pusher bolt capability   | Can be aided with pry bars  |
| ⑧ Volute Casing Heater                       | Discreet heater port permits heater insertion into discharge side of volute       | Heater probe can be inserted into optional service tee in pump drain port     |

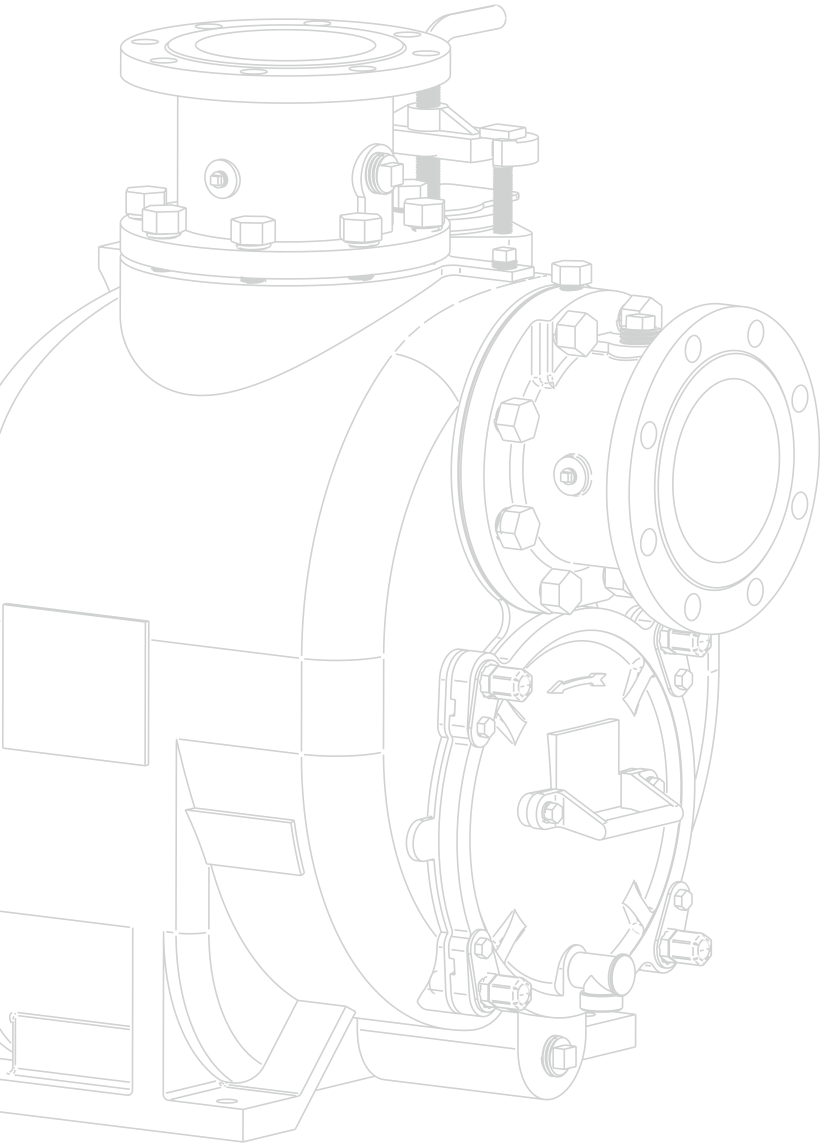

QUALITY | COMMITMENT | ADAPTABILITY

## CANADA

Headquarters

1180 Britannia Road East,  
Mississauga, Ontario, L4W 1C8

☎ 1 - 866 - 217 - 7867

✉ sales@rotechpumps.com



## USA

Headquarters

16640, W Basin St,  
Odessa, Texas 79763

☎ 432 - 556 - 8652

✉ usasales@rotechpumps.com

[www.rotechpumps.com](http://www.rotechpumps.com)