

- 1 DIMENSION "A" IS APPROXIMATELY .72 [18.2] FOR PACKING PUMPS WITH PACKING NUT INSTALLED. DIMENSION "A" IS 1.26 [32.0] FOR LIP SEAL PUMPS.
- 2 STANDARD UPPER DRIVE SHOWN. FOR LOWER DRIVE ARRANGEMENT DIMENSION "B" IS 1.33 [33.7].
- 3 DIMENSION "C" IS APPROXIMATELY 2.25 [57.2] FOR PACKING PUMPS WITH LANTERN LUBE PORT OPTION. DIMENSION "C" IS 2.05 [52.1] FOR LIP SEAL PUMPS.
- 4 DIMENSION "D" IS N/A FOR PACKING PUMPS. DIMENSION "D" IS 2.05 [52.1] FOR LIP SEAL PUMPS.

GENERAL DESCRIPTION:

Chemsteel™ pumps are designed to handle common and highly corrosive liquids that must be pumped under pressure. Manufactured to extremely precise tolerance, the Chemsteel™ pump line prevents system contamination while maintaining the purity and integrity of the liquid being pumped. Its rugged, three-section, o-ring sealed thru-bolt construction provides ease of servicing and parts replacement. Helical gearing offers noise reduction by as much as 10db, while the tandem pumps double the output flow for a single fluid, or with isolation, handle other fluids in direct ratio to the first. Additionally, Chemsteel™ pumps offer bi-directional operation for applications requiring reversing flow.

LIFE CYCLE/COST OF OWNERSHIP

Pump design and materials selection, together provide the longest life available from a gear pump.

Key attributes include:

- Gear & bearing combinations of metallic and nonmetallic wear surfaces.
- Slotted bearings to lubricate shaft and gear surfaces.
- Hydraulic porting to balance axial thrust and to reduce wear.
- Ample port sizing to reduce the likelihood of cavitation when inlet pressure is marginal.
- Effective housing seals with elastic memory prevent leakage of corrosives.

SPECIFIC SOLUTIONS

Gear/bearing design allows for "trimming" for optimizing the pump's maximum flow to reach minimum turndown or to match flow to a specific OEM's requirement.

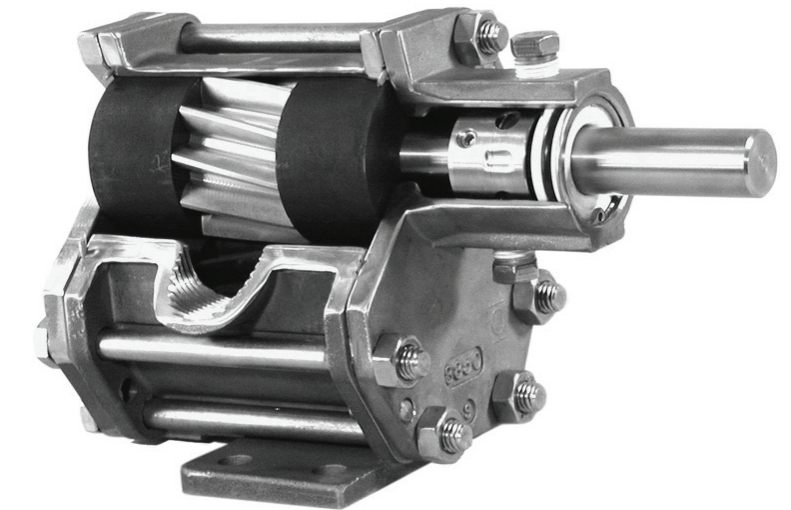

A full range of accessories are available including:

- close coupled mounting kits
- baseplate/pedestal mounting kits
- line mounted pressure relief valves

PERFORMANCE:

CAPACITY WATER AT 70°F

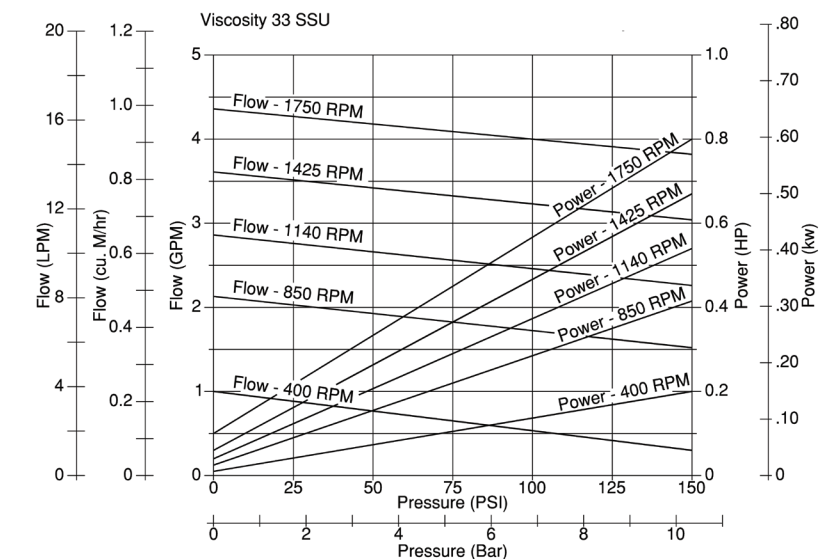

Notes: For continuous service:

- Plastic/Plastic gear combinations are limited to 50 psi or 3.5 bar.
- Metal/Plastic gear combinations are limited to 100 psi or 7 bar.
- Metal/Metal gear combinations are limited to 150 psi or 10.3 bar.
- Horsepower requirements increase for viscous fluids.

To order a CHEMkit™, simply add a "K" to the end of the model number. A repair kit contains the following parts: bearings, gears, o-rings, shafts, keys, and retaining ring.

Special materials combinations are available for specific liquids:

- Stainless or Alloy C housing construction.
- Gears available in 316 stainless, W88 stainless and Alloy C. Also in PTFE, Polyphenylenesulfide and Polyaryletherketone
- Shafts are 316 stainless steel or Alloy C.
- Bearings available in Carbon or PTFE.

Full range of seal options including lip seal, packing and mechanical designs.

FIT

Connections are 1/2" female NPT or BSPT, pump hardware is metric and close couple adapters

mount to both NEMA and IEC standard motor frame sizes for world wide acceptance. "Near" dimensional interchangeability offers easy upgrade to Chemsteel™ pump. The port size is the same as competitive pumps.

MAINTENANCE

A three-part housing provides easy disassembly and service. Full size bearings match the gear diameter, and eliminate the need for separate wear plates. TFE encapsulating silicone o-ring pump housing seals provide elastic memory to assure an effective long lasting seal and thus avoiding the re-torquing required of pumps using pure TFE.

MODEL	S207	
Maximum flow @1750 rpm	4 GPM	15.1 LPM
Theoretical displacement	11.2 cc/revolution	
Maximum differential pressure	150 psig	10.3 bar
Maximum system pressure	300 psig	20.7 bar
Maximum speed	1800 RPM	
Maximum fluid temperature	450° F	232° C
Minimum fluid temperature	-50° F	-46° C
NPSHR @ 1750 RPM	4 feet	1.2 meters
Standard port size	1/2" FNPT	1/2" BSPT
Weight (lbs)	6 lbs	2.7 kg

CLOSE-COUPLED DIMENSIONS: C3 & C4 (C3 SHOWN)

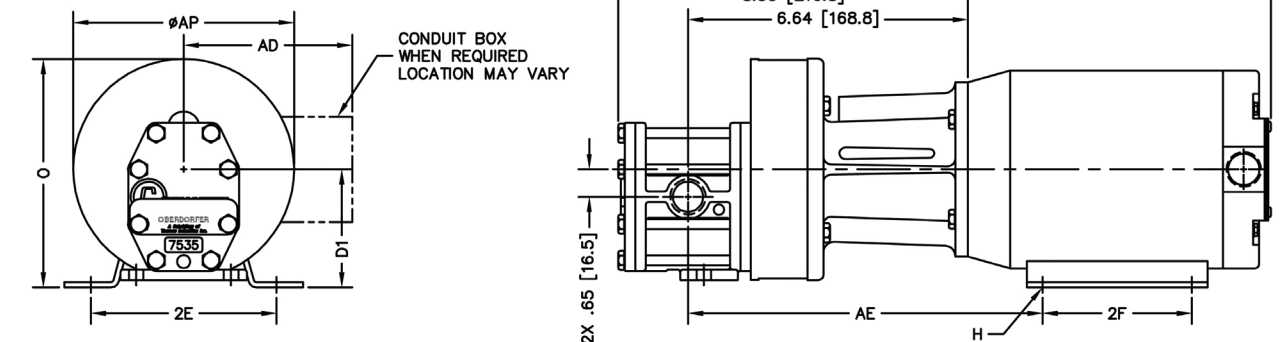

MOUNTED ADAPTER CODE	KIT PART NO.	MOTOR FRAME		D1	2E	2F	H	① O	① AP	① AC	① AD	AE
C3	M2AD71E	IEC 71, B14 FACE	inches	2.80	4.41	3.54	ϕ .28 SLOT	5.14	4.69	17.61	4.00	8.42
			millimeters	71	112	89.9	ϕ 7 SLOT	130.6	119.1	447.3	102	213.9
C4	M2AD80E	IEC 80, B14 FACE	inches	3.15	4.92	3.94	ϕ .39 SLOT	6.00	5.69	17.84	4.51	8.62
			millimeters	80	125	100.1	ϕ 10 SLOT	152.4	144.5	453.1	116	218.9

① These dimensions vary depending on hp, enclosure, speed and motor manufacturer. Specifications are subject to change without notification.

CLOSE-COUPLED DIMENSIONS: C1 & C2 (C1 SHOWN)

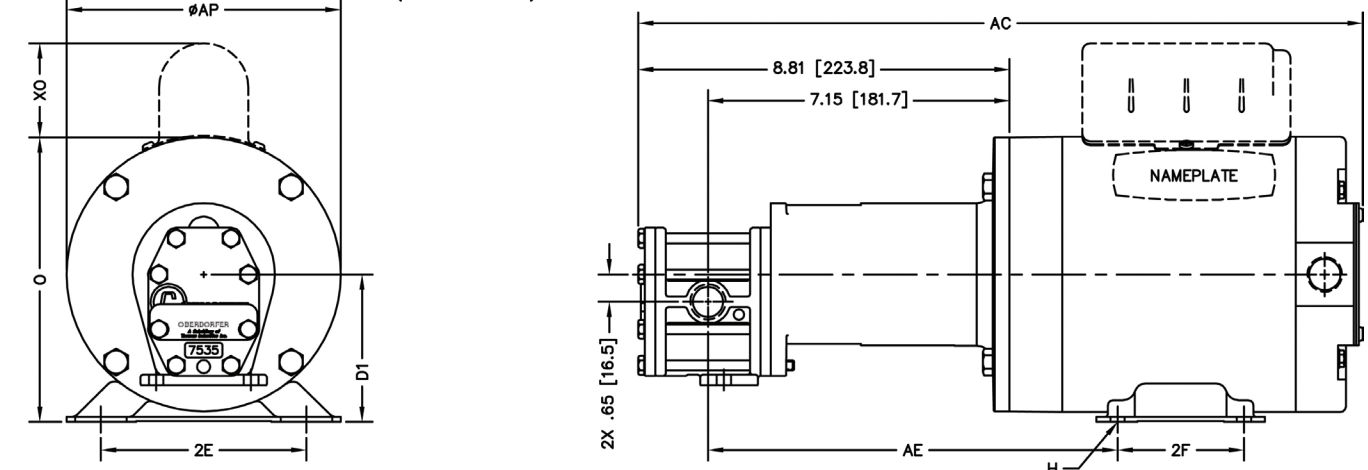

MOUNTED ADAPTER CODE	KIT PART NO.	MOTOR FRAME		D1	2E	2F	H	① O	① AP	① X0	① AC	AE	
C1	M2AD56	56C	inches	3.50	4.88	3.00	ϕ .34 SLOT	6.88	6.63	2.25	17.18	9.71	
			millimeters	88.9	124	76.2	ϕ 8.6 SLOT	174.8	168.4	57.2	436.4	246.6	
C2	M2AD45T	143TC	145TC	inches	3.50	5.50	4.00 5.00	ϕ .34 SLOT	6.88	6.63	2.25	18.37/19.87	9.53
				millimeters	88.9	139.7	102 127	ϕ 8.6 SLOT	174.8	168.4	57.2	466.6/504.7	242.1
		182C	184C	inches	4.50	7.50	4.50 5.50	ϕ .41 SLOT	8.69	7.88	2.38	21.09/20.31	10.03
				millimeters	114.3	190.5	114.3/139.7	ϕ 10.41 SLOT	220.7	200	60.3	535.7/515.9	254.8

① These dimensions vary depending on hp, enclosure, speed and motor manufacturer. Specifications are subject to change without notification.