

Variable Area Flow Meters Rotameters



General

- **Size:** 3/8"–2 1/2"
- **Total Flow Range:** 0.01–264 gpm
- **Tube Material:** PA, PSU, PVC transparent
- **Seal:** EPDM, FPM
- **Float:** PVDF, PVDF-HP transparent
- **End Connection:** Solvent cement socket, threaded, flanged, fusion spigot union, fusion socket union

Key Certifications and Conformity

- **FDA CFR 21 177.1520:** PP and PVDF
- **FDA CFR 21 177.2600:** EPDM and FPM
- **FDA CFR 21 177.1550:** PTFE
- **USP 25 Class VI (physiological non-toxic):** PP and PVDF
- **VDE/VDI 3513:** Accuracy class 4

Optional Features

- **Limit Switches:** Mechanical
- **Float Position Sensor:** 4–20mA
- **Scale:** Custom scales available upon request
- **End Connection:** Alternatives available upon request
- **Face Seals:** Alternatives available upon request
- **Cleaned:** Silicone free/oil free

Material Specification

PVC components shall meet ASTM D1784 cell classification 12454 standards. CPVC components shall meet ASTM D1784 cell classification 23447-B standards. PP components shall meet ASTM D5847-14 cell classification PP0510B66851 standards. ABS valves shall meet ASTM D3965 cell classification 42222 standards. PVDF components shall be type 1, grade 2 according to ASTM D3222 standards. Rotameters of all materials shall be RoHS compliant.

Definition of Type

Type	Connection ²	Description
336	IPS	Standard tube, 335 mm
335	Metric	Standard tube, 335 mm
335-HP	Metric	UPW tube, 335 mm
350 ¹	Metric	Standard tube, 350 mm
807	IPS	Short tube, 200 mm
807-HP	Metric	UPW tube, 200 mm

¹ Not detailed in this document

² Standard connection standard listed, alternatives available upon request

Definition of SK

All rotameter tubes, accessories, complete assemblies as well as many spare parts have an associated SK number. This number is used to define component compatibility. Please note that only products with the same SK number are compatible with each other.

Important: The UPW Rotameter Family does not completely follow this structure in that the UPW SK numbers should only be used for sizing electronic feedback accessories. The UPW subcomponents are specifically designed for this product line and differ from the standard subcomponents. Optional scales, unless specifically designed for the UPW tube, will therefore not read accurately.

Components

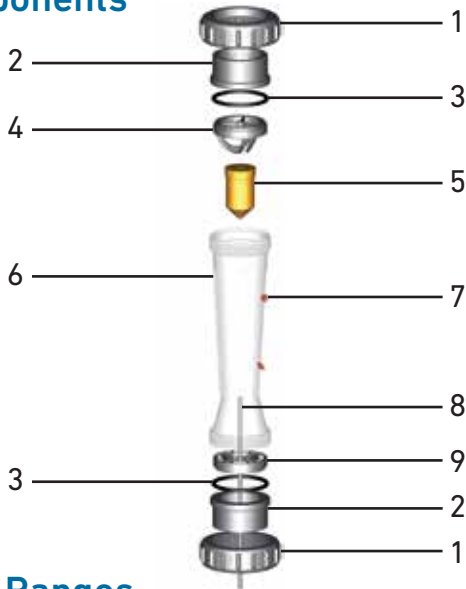

Components

Part	Description	Material
1	Union Nut	PVC, PVDF
2	Union End	PVC, CPVC, PP, PVDF
3	Union O-ring	EPDM, FPM
4	Top Insert	PVDF,
5	Float	PVDF, PVDF transparent
6	Tube	PSU, PA, PVC transparent
7	Flow Indicator Bracket	PS
8	Guide Rod ¹	PEEK, SS, PVDF coated SS
9	Bottom Insert	PVDF

¹ Required for rotameters SK31-42 only

Flow Ranges

The following tables detail the available scale ranges in gal/min within each rotameter family based on water applications at 68° F.

Type 335/336: Scale Range

Size (inch)	d (mm)	SK	Scale Range (gpm)
1	32	10	0.22 - 2.2
1	32	11	0.44 - 4.4
1½	40	15	0.66 - 6.6
1½	40	16	1.10 - 11.0
1½	50	19	0.88 - 8.8
1½	50	20	1.32 - 13.2
1½	50	21	2.64 - 26.4
2	63	29	2.64 - 26.4
2	63	30	4.4 - 44.0
2	63	31	6.6 - 66.0
2½	75	40	8.8 - 88.0
2½	75	41	13.2 - 132.0
2½	75	42	35.2 - 264.0

Type 807: Scale Range

Size (inch)	d (mm)	SK	Scale Range (gpm)
¾	16	50	0.01 - 0.11
¾	16	51	0.02 - 0.22
¾	16	52	0.04 - 0.44
½	20	60	0.03 - 0.35
½	20	61	0.06 - 0.66
½	20	62	0.08 - 0.88
1	32	70	0.06 - 0.66
1	32	71	0.13 - 1.32
1	32	72	0.22 - 2.20
1	32	73	0.44 - 4.40

UPW Scale Range

d (mm)	SK	Type	Scale Range (gpm)
32	70	807-HP	0.36 - 1.0
32	71	807-HP	0.4 - 1.4
32	73	807-HP	0.6 - 3.5
32	11	335-HP	0.44 - 4.4
50	20	335-HP	1.3 - 13.2
50	21	335-HP	2.6 - 26.4
63	30	335-HP	4.4 - 35.2
63	31	335-HP	6.6 - 66.0
75	40	335-HP	8.8 - 88.0
75	41	335-HP	13.2 - 127.7

Measurement Accuracy

Based on water applications at 68° F.

Flowrate (% of Scale)	Measured Error (%)	Measured Error (Engineering Units)
10	13.0	1.3
20	8.0	1.6
30	6.33	1.9
40	5.50	2.2
50	5.0	2.5
60	4.83	2.9
70	4.43	3.1
80	4.25	3.4
90	4.11	3.7
100	4.0	4.0

In accordance with VDE/VDI 3515, Accuracy Class 4

Optional Scales

Units	335/336	807	UPW
gpm	✓	✓	-
l/h	✓	✓	-
Percent (10-100%)	✓	✓	-
m ³ /h	✓	-	-
l/h, NaOH 30%	✓	✓	-
l/h, NaOH 50%	✓	✓	-
l/h, HCL 30%	✓	✓	-
Nm ³ /h, Air	✓	✓	-

Important: The defined Flow Ranges for each family of rotameter are accurate for water at 68°F with gpm as the unit of measurement. The equivalent l/h or m³/h scale range can be calculated using these tables and converting the unit of measurement. The optional chemical and air scale ranges shown at left are not directly convertible using this same method because of the changes in media properties. Please consult GF for correct scale ranges for these types of scales.

Pressure Temperature Curves

The following graphs are based on a 25 year lifetime water or similar media application

PVC

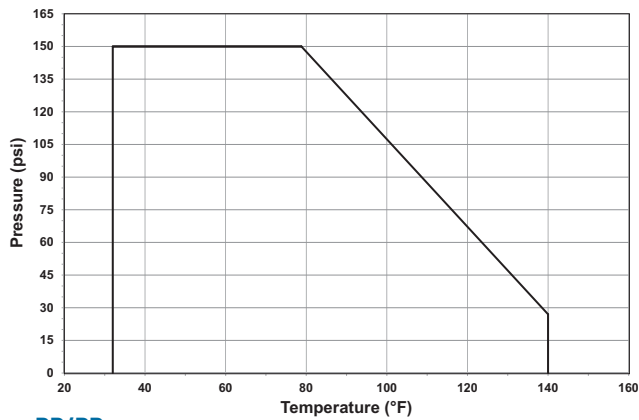

CPVC

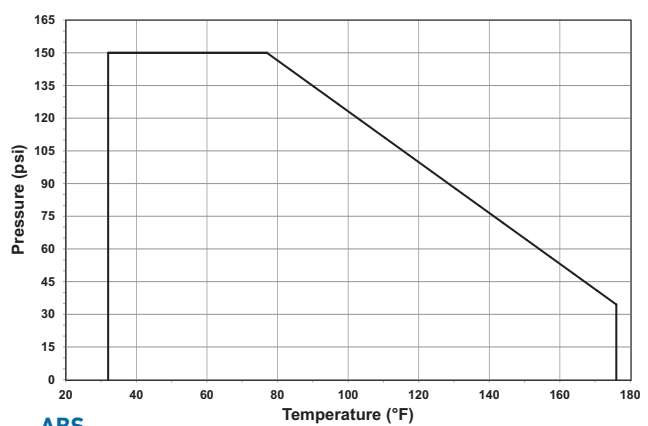

PP/PPn

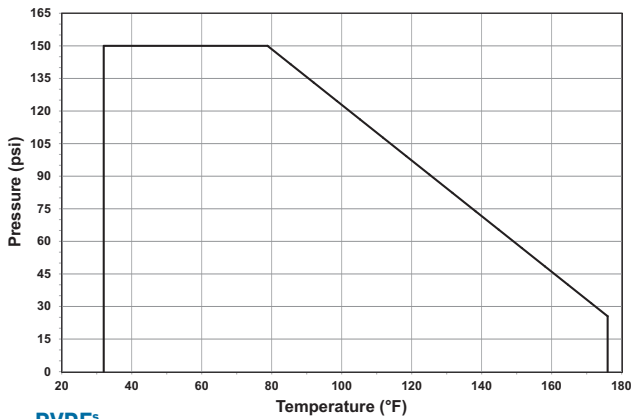

ABS

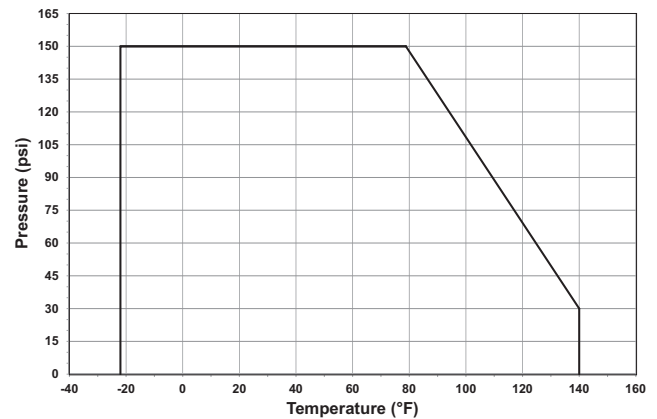

PVDF^s

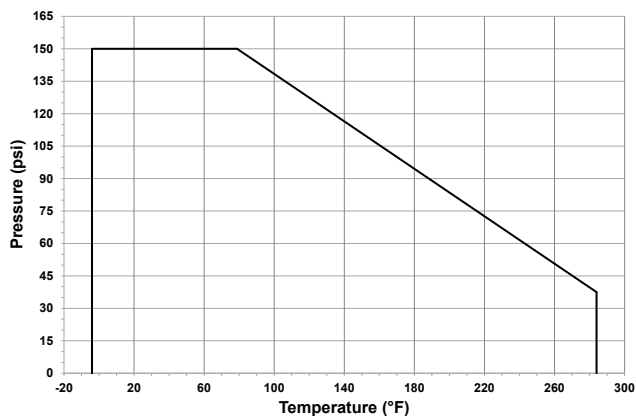

Pressure-Temperature

Material	Temperature Range (°F)	Max Pressure (psi)
PVC	32 to 140	150
CPVC	32 to 176	150
PP/PPn	32 to 176	150
ABS	-40 to 140	150
PVDF	-4 to 284	150
PA	32 to 140	150
PSU	32 to 194	150

An assembly's rated temperature range is constrained to the limiting material's range. Both the tube and end connection material need to be considered when determining the full assembly temperature range.

Pressure Loss

The following information is based on water applications at 68° F. Pressure loss is constant over the scale range.

Type 807

Size (inch)	d (mm)	SK	Pressure Loss (psi)
3/8	16	50	0.06
3/8	16	51	0.06
3/8	16	52	0.06
1/2	20	60	0.12
1/2	20	61	0.12
1/2	20	62	0.12
1	32	70	0.07
1	32	71	0.07
1	32	72	0.07
1	32	73	0.07

UPW

d (mm)	SK	Type	Pressure Loss (psi)
32	70	807-HP	0.07
32	71	807-HP	0.07
32	73	807-HP	0.07
32	11	335-HP	0.34
50	20	335-HP	0.36
50	21	335-HP	0.36
63	30	335-HP	0.36
63	31	335-HP	0.43
75	40	335-HP	0.44
75	41	335-HP	0.68

Type 335/336

Size (inch)	d (mm)	SK	Pressure Loss (psi)
1	32	10	0.33
1	32	11	0.33
1 1/4	40	15	0.33
1 1/4	40	16	0.33
1 1/2	50	19	0.36
1 1/2	50	20	0.36
1 1/2	50	21	0.36
2	63	29	0.36
2	63	30	0.36
2	63	31	0.41
2 1/2	75	40	0.66
2 1/2	75	41	0.66
2 1/2	75	42	0.68

Correction Factors

Correction factors are used when application parameters differ from those at which the provided scale was calibrated to. All GF scales are calibrated at 68° F with water, a specific chemical media (HCL, NaOH) or air as the media depending on the scale. If system conditions differ from these parameters an operator can multiply the scale reading by the correction factors listed below to determine the actual flow volume.

Liquid

Specific Gravity	Correction Factor
0.5	1.464
0.6	1.320
0.7	1.220
0.8	1.133
0.9	1.060
1.0	1.000
1.1	0.946
1.2	0.896
1.3	0.857
1.4	0.820
1.5	0.787
1.6	0.755
1.7	0.726
1.8	0.700
1.9	0.676
2.0	0.654

Temperature

Operating Temperature (°F)	Correction Factor
32	1.035
50	1.018
68	1.000
86	0.984
104	0.967
122	0.953
140	0.938
158	0.924
176	0.927

Gas

Media	Density (kg/m³)	Correction Factor
Air	1.293	1.0
Oxygen	1.429	0.953
Nitrogen	1.251	1.017
Ammonia	0.771	1.295
Acetylene	1.171	1.050
Chlorine	3.220	0.633
Hydrogen	0.089	3.810
Carbon Dioxide	1.997	0.800
Sulphur Dioxide	2.926	0.668
Coal Gas	0.550	1.532
Propane	2.020	0.800

Dimensions

The following tables are shown in millimeters unless otherwise specified

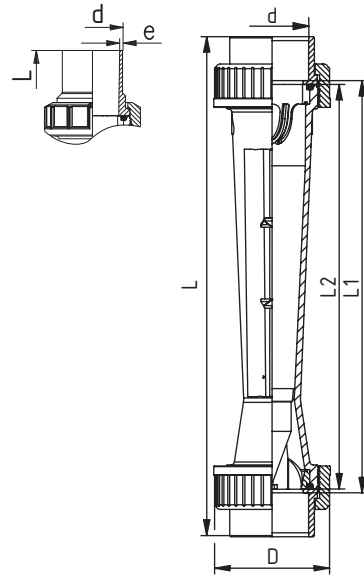

Type 335/336: All Materials

Size (inch)	d (mm)	SK	D	L2
1	32	10	58	335
1	32	11	58	335
1¼	40	15	72	335
1¼	40	16	72	335
1½	50	19	83	335
1½	50	20	83	335
1½	50	21	83	335
2	63	29	101	335
2	63	30	101	335
2	63	31	101	335
2½	75	40	135	335
2½	75	41	135	335
2½	75	42	135	335

Type 335/336

Size (inch)	SK	PVC				CPVC			
		IPS Socket		Threaded NPT		IPS Socket		Threaded NPT	
		L	L1	L	L1	L	L1	L	L1
1	10	400	341	386	341	400	341	386	341
1	11	400	341	386	341	400	341	386	341
1¼	15	406	341	394	341	406	341	394	341
1¼	16	406	341	394	347	406	341	394	347
1½	19	413	341	405	357	413	341	405	357
1½	20	413	341	405	357	413	341	405	357
1½	21	413	341	405	357	413	341	405	357
2	29	419	341	419	369	419	341	419	369
2	30	419	341	419	369	419	341	419	369
2	31	419	341	419	369	419	341	419	369
2½	40	429	341	437	365	433	343	437	365
2½	41	429	341	437	365	433	343	437	365
2½	42	429	341	437	365	433	343	437	365

Type 335/336

d(mm)	SK	ABS Metric Socket	
		L	L1
32	10	390	346
32	11	390	346
40	15	398	342
40	16	398	342
50	19	405	343
50	20	405	343
50	21	405	343
63	29	419	343
63	30	419	343
63	31	419	343
75	40	435	345
75	41	435	345
75	42	435	345

Type 335/336

d(mm)	SK	PP						PVDF					
		Metric Socket		IR/Butt Fusion		Threaded NPT		Metric Socket		IR/Butt Fusion		Threaded NPT	
		L	L1	L	e	L	L1	L	L1	L	e	L	L1
32	10	382	342	456	2.9	392	348	382	346	318	2.4	53	63
32	11	382	342	456	2.9	392	348	382	346	318	2.4	53	63
40	15	386	342	462	3.7	398	350	386	346	460	2.4	398	352
40	16	386	342	462	3.7	398	350	386	346	460	2.4	398	352
50	19	393	343	469	4.6	405	359	393	347	466	3.0	405	359
50	20	393	343	469	4.6	405	359	393	347	466	3.0	405	359
50	21	393	343	469	4.6	405	359	393	347	466	3.0	405	359
63	29	401	343	475	5.8	419	371	401	347	472	3.0	419	371
63	30	401	343	475	5.8	419	371	401	347	472	3.0	419	371
63	31	401	343	475	5.8	419	371	401	347	472	3.0	419	371
75	40	435	377	469	6.8	-	-	435	377	495	3.6	-	-
75	41	435	377	469	6.8	-	-	435	377	495	3.6	-	-
75	42	435	377	469	6.8	-	-	435	377	495	3.6	-	-

Dimensions

The following tables are shown in millimeters unless otherwise specified

Type 807: All Materials

Size (inch)	d (mm)	SK	D	L2
3/8	16	50	35	200
3/8	16	51	35	200
3/8	16	52	35	200
1/2	20	60	43	200
1/2	20	61	43	200
1/2	20	62	43	200
1	32	70	60	200
1	32	71	60	200
1	32	72	60	200
1	32	73	60	200

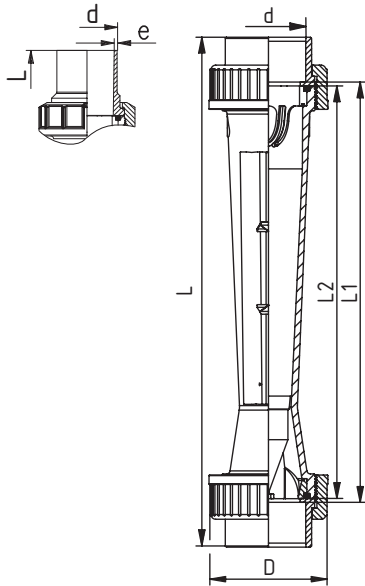

Type 807

Size (inch)	SK	PVC/CPVC				ABS	
		IPS Socket		Threaded NPT		Metric Socket	
		L	L1	L	L1	L	L1
3/8	50	244	206	234	208	-	-
3/8	51	244	206	234	208	-	-
3/8	52	244	206	234	208	-	-
1/2	60	250	206	238	204	242	208
1/2	61	250	206	238	204	242	208
1/2	62	250	206	238	204	242	208
1	70	265	207	251	207	255	211
1	71	265	207	251	207	255	211
1	72	265	207	251	207	255	211
1	73	265	207	251	207	255	211

Type 807

d (mm)	SK	PP					
		Metric Socket		IR/Butt Fusion		Threaded NPT	
		L	L1	L	e	L	L1
16	50	236	206	-	-	240	214
16	51	236	206	-	-	240	214
16	52	236	206	-	-	240	214
20	60	238	206	242	1.9	242	208
20	61	238	206	242	1.9	242	208
20	62	238	206	242	1.9	242	208
32	70	247	207	257	2.9	257	213
32	71	247	207	257	2.9	257	213
32	72	247	207	257	2.9	257	213
32	73	247	207	257	2.9	257	213

UPW

d(mm)	SK	PVDF-HP IR/Butt Fusion Spigot			
		D	e	L	L2
32	70	60	2.4	318	200
32	71	60	2.4	318	200
32	73	60	2.4	318	200
32	11	60	2.4	453	335
50	20	83	3.0	466	335
50	21	83	3.0	466	335
63	30	103	3.0	472	335
63	31	103	3.0	472	335
75	40	122	3.6	495	335
75	41	122	3.6	495	335

Type 807

d (mm)	SK	PVDF					
		Metric Socket		IR/Butt Fusion		Threaded NPT	
		L	L1	L	e	L	L1
16	50	236	210	-	-	240	212
16	51	236	210	-	-	240	212
16	52	236	210	-	-	240	212
20	60	242	210	306	1.9	242	208
20	61	242	210	306	1.9	242	208
20	62	242	210	306	1.9	242	208
32	70	247	211	318	2.4	247	257
32	71	247	211	318	2.4	247	257
32	72	247	211	318	2.4	247	257
32	73	247	211	318	2.4	247	257