

## ELECTRONIC INTERFACE for Diaphragm Pumps

RELEASED: 3-26-13  
(REV. B)

**READ THIS MANUAL CAREFULLY BEFORE INSTALLING,  
OPERATING OR SERVICING THIS EQUIPMENT.**

**It is the responsibility of the employer to place this information in the hands of the operator. Keep for future reference.**

### PUMP DATA

**PE03X-XXX-XXX-XXXX** is PE series 3/8" Compact Diaphragm Pumps with electronic interface

**PE05X-XXX-XXX-XXXX** is PE series 1/2" Compact Diaphragm Pumps with electronic interface

**PE07X-XXX-XXX-XXXX** is PE series 3/4" Compact Diaphragm Pumps with electronic interface

### GENERAL DESCRIPTION

This manual is supplemental information for the electronic interface options on the PE series of pumps. For complete pump installation, disassembly and reassembly, safety information, and other general pump information, please refer to the PD pump manual that was also included with the pump. This electronic interface includes options for solenoid control, end of stroke feedback, leak detection (diaphragm failure), cycle counting on the major valve, and a ported motor with no major valve for user-supplied control directly to the two diaphragm air chambers.

Solenoid control allows the cycle rate of the pump to be controlled electronically. With Solenoid control, when the solenoid is energized, the pump strokes and dispenses the fluid in one chamber. When the solenoid is de-energized, the pump strokes in the opposite direction, dispensing the fluid in the other chamber. By providing continuous ON - OFF signals to the solenoid, the fluid transfer rate may be increased or decreased remotely. End of stroke feedback can be used in conjunction with the solenoid valve to cycle the pump based upon completion of each stroke.

The leak detection option incorporates an optical fluid sensor in each air chamber to provide a signal when a diaphragm has failed and fluid is leaking through the pump. The cycle counter option provides a closed contact output each time the pump completes a cycle. This option is not available combined with solenoid control.

The ported motor with no major valve is provided as an option for users who want to supply compressed air directly to each diaphragm and control the operation of the pump with their own external air controls.

The leak detection option incorporates an optical fluid sensor in each air chamber to provide a signal when a diaphragm has failed and fluid is leaking through the pump.

The cycle counter option provides a closed contact output each time the pump completes a cycle. This option is not available combined with solenoid control.

The ported motor with no major valve is provided as an option for users who want to supply compressed air directly to each diaphragm and control the operation of the pump with their own external air controls.

### MODEL DESCRIPTION CHART

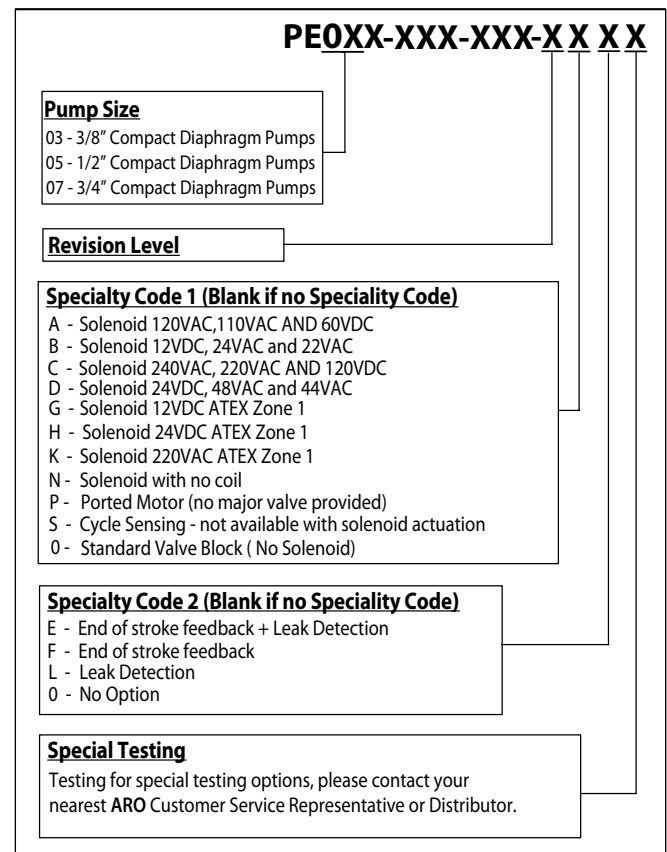

## PARTS LIST / PE0XX-XXX-XXX-XXXX

Item	Description	Part no	Qty
107	Plug, Small	96353	(1)
111	Major Valve Spool (PE0XX-XXX-XXX-X0XX)	95919	(1)
	(PE0XX-XXX-XXX-XAXX, PE0XX-XXX-XXX-XBXX, PE0XX-XXX-XXX-XCXX, PE0XX-XXX-XXX-XDXX, PE0XX-XXX-XXX-XGXX, PE0XX-XXX-XXX-XHXX, PE0XX-XXX-XXX-XKXX, PE0XX-XXX-XXX-XNXX)	96955	(1)
	(PE0XX-XXX-XXX-XSXX)	96562	(1)
126	Pipe Plug (1/4 - 18 N.P.T. x 7/16") (PE0XX-XXX-XXX-XXFX, PE0XX-XXX-XXX-XX0X)	93832-3	(2)
128	Plug (#10 - 32 x 5/32") (PE0XX-XXX-XXX-XPXX, PE0XX-XXX-XXX-XXLX, PE0XX-XXX-XXX-XX0X)	59632-1	(1)
132	Air Manifold Gasket	96214-1	(1)
135	Valve Block	96204	(1)
	(for PE0XA-XXX-XXX-XXXX)	95980	(1)
	Porting Plate (ported motor only) (for PE0XX-XXX-XXX-XPXX)	96382	(1)
	(for PE0XA-XXX-XXX-XPXX)	96382-4	(1)
136	Plug, Large (PE0XX-XXX-XXX-X0XX, PE0XX-XXX-XXX-XSXX)	96352	
	(PE0XX-XXX-XXX-XAXX, PE0XX-XXX-XXX-XBXX, PE0XX-XXX-XXX-XCXX, PE0XX-XXX-XXX-XDXX, PE0XX-XXX-XXX-XGXX, PE0XX-XXX-XXX-XHXX, PE0XX-XXX-XXX-XKXX, PE0XX-XXX-XXX-XNXX)	96971	(1)
137	"O" Ring (1/16" x 1-5/8" o.d.)	Y325-29	(3)
138	"U" Cup Packing (1/8" x 1" o.d.)	94395	(1)
139	"U" Cup Packing (1/8" x 1-7/16" o.d.)	96383	(1)
200	Porting Gasket	96364	(1)
283	Diaphragm Failure Detector (PE0XX-XXX-XXX-XXEX, PE0XX-XXX-XXX-XXLX)	96270-1	(2)
140	Valve Insert	93276	(1)
141	Valve Plate	96173	(1)
166	"O" Ring (1/16" x 1-1/4" o.d.)	Y325-24	(1)
403	Valve (All PE0XX with Solenoid)	114102	(1)
404	Tubing (0.417 ft) (PE0XX-XXX-XXX-XXEX, PE0XX-XXX-XXX-XXFX)	94981-XXX-X	-
405	Elbow (PE0XX-XXX-XXX-XXEX, PE0XX-XXX-XXX-XXFX)	59756-103	(1)
408	Male Connector Fitting (PE0XX-XXX-XXX-XXEX, PE0XX-XXX-XXX-XXFX)	59764-4	(1)

Item	Description	Part no	Qty
410	Sensor (for Cycle Sensing) (PE0XX-XXX-XXX-XXSX)	95276	(1)
411	Adapter (for Cycle Sensing) (PE0XX-XXX-XXX-XXSX)	96563	(1)
412	Wiring	96965	(1)
413	Coil Nut (All PE0XXX with Solenoid)	119380	(1)
414	Coil ,120 VAC (PE0XX-XXX-XXX-XAXX)	116218-33	(1)
	Coil ,240 VAC (PE0XX-XXX-XXX-XCXX)	116218-35	(1)
	Coil, 12 VDC (PE0XX-XXX-XXX-XBXX)	116218-38	(1)
	Coil, 24VDC ATEX (PE0XX-XXX-XXX-XHXX)	117345-39	(1)
	Coil, 24 VDC (PE0XX-XXX-XXX-XDXX)	116218-39	(1)
	Coil, 220 VAC ATEX (PE0XX-XXX-XXX-XKXX)	117345-35	(1)
	Coil, 12 VDC ATEX (PE0XX-XXX-XXX-XGXX)	117345-38	(1)
415	O-Ring (All PE0XX with Solenoid)	114103	(1)
416	O-Ring (All PE0XX with Solenoid)	114104	(1)
417	Screw (All PE0XX with Solenoid)	96728647	(2)
418	Tube (All PE0XX with Solenoid)	15309974	(1)
419	Seal (All PE0XX with Solenoid)	96957	(1)
420	Snap Ring (All PE0XX with Solenoid)	Y147-43	(1)
421	Retainer (All PE0XX with Solenoid)	15309990	(1)
422	Manifold (PE0XX-XXX-XXX-XXEX, PE0XX-XXX-XXX-XXFX)	96969	(1)
423	Nut (PE0XX-XXX-XXX-XXEX, PE0XX-XXX-XXX-XXFX)	47496446001	(1)
424	Lock Washer (PE0XX-XXX-XXX-XXEX, PE0XX-XXX-XXX-XXFX)	47496443001	(1)
425	Magnet	95275	(1)
426	Mounting Strap (PE0XX-XXX-XXX-XXEX, PE0XX-XXX-XXX-XXFX)	96970	(1)
427	Pressure Sensor (PE0XX-XXX-XXX-XXEX, PE0XX-XXX-XXX-XXFX)	96961	(1)
429	Solenoid Muffler (All PE0XX with Solenoid)	116464	(1)

## GENERAL DESCRIPTION

Without end of stroke feedback, solenoid control can only be used to cycle the pump based on timing. The following curves represent the flow rates of a pump based on timed operation of the solenoid at a common operating point of 70 psi air pressure and 30 psi of back pressure.

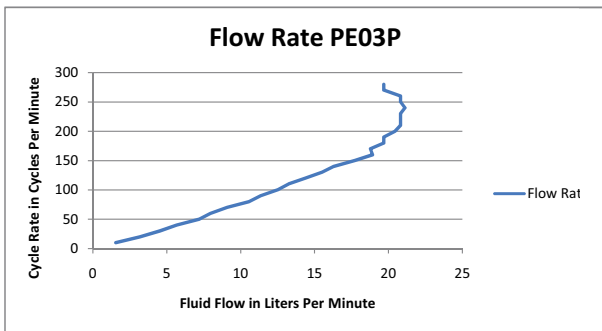
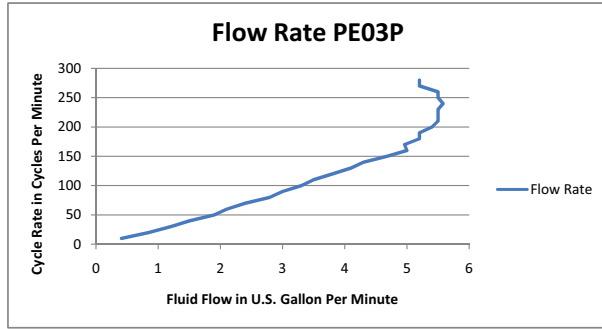

**Figure 1**

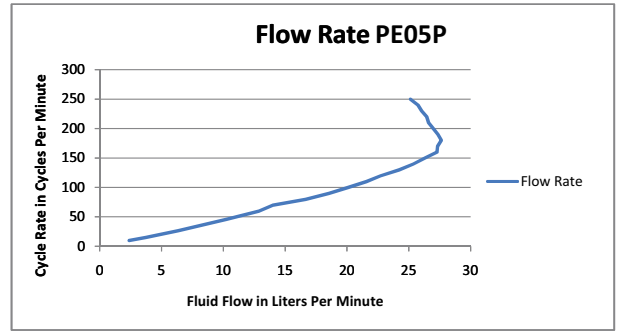
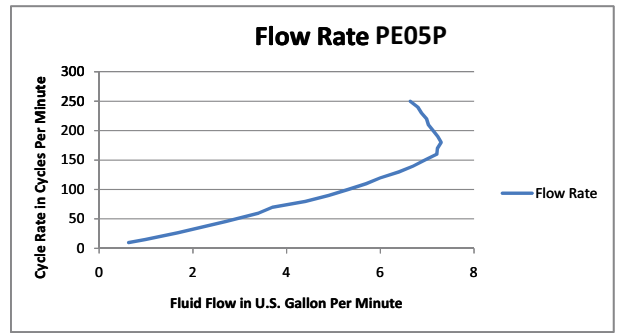

**Figure 2**

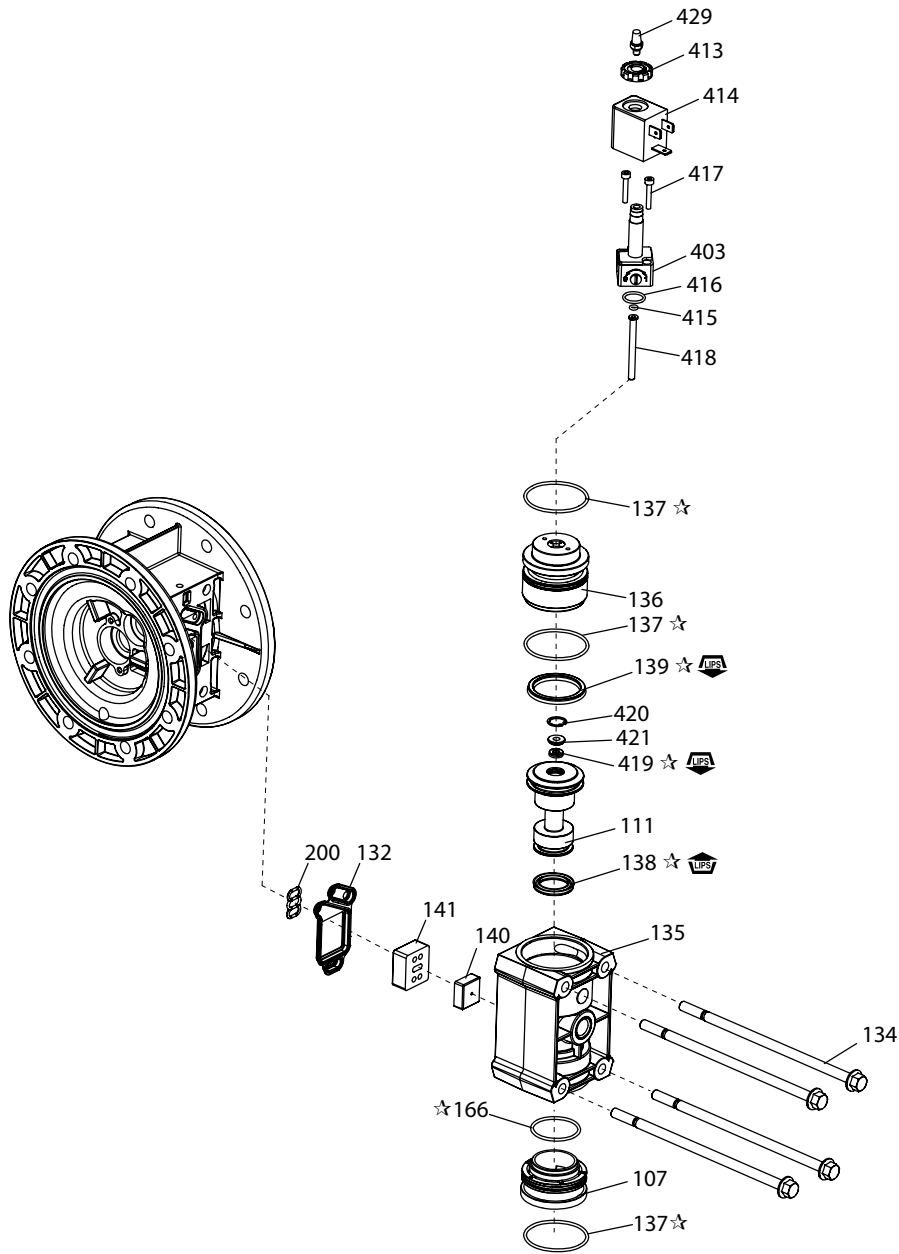

**Figure 3**

**LUBRICATION / SEALANTS**

☆ Apply Lubriplate FML-2 grease (94276) to all "O" rings, "U" cups and mating parts.

**GENERAL DESCRIPTION**

With end of stroke feedback from a pressure switch, the solenoid can be used to cycle the pump based on known feedback that the pump has fully completed each stroke.

**PRESSURE SWITCH OPERATION**

A calibration procedure is necessary for proper operation of the pressure switch and accurate end of stroke feedback from the pump. The Reset ring will always have a lower pressure value than the Set ring.

1. Determine the operating air pressure of the pump.
2. The Reset ring should be set to approximately 25% of the operating pressure of the pump with a minimum of 10 PSI.
3. The **Set** ring should be set to approximately 50% of the operating pressure of the pump. This value is more variable depending on the specific operating conditions. The switch may function properly at much lower values for the Set ring if the pump is running slowly, or at lower operating pressures. In general, high operating speeds and pressures require a higher setting value of the Set ring.
4. Operate the pump slowly to ensure proper operation of the pressure switch. When the pump has shifted to one side, the yellow LED will illuminate and remain on until the pump shifts back to the opposite side.
5. If the operating pressure of the pump changes, the **Set** ring may need to be adjusted accordingly.

**SETTING / OPERATION**

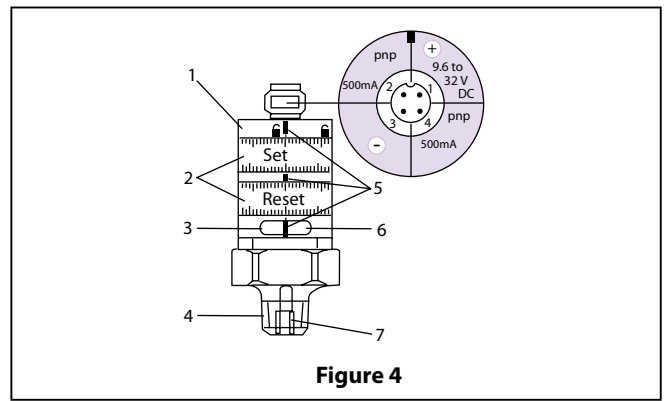

Figure 4

1. Locking Ring
2. Setting Rings (manually adjustable after unlocking)
3. LED green: supply voltage O.K.
4. Process connection 1/4" NPT; tightening torque 25 Nm
5. Setting Marks
6. LED yellow: Set values reached, OUT1 = ON / OUT2 = OFF
7. Internal Thread M5
  - Minimum distance between Set and Reset = 2% of the final value of the measuring range.
  - To obtain the setting accuracy: Set both rings to the minimum value, then set the requested value.

**PART LIST / PE0XX-XXX-XXX-XXEX, PE0XX-XXX-XXX-XXFX**

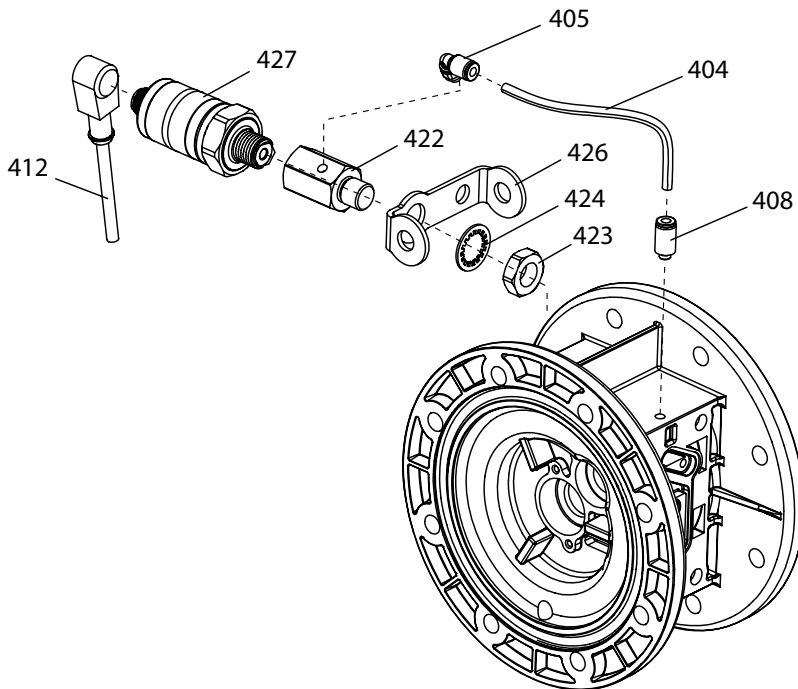

Figure 5

## LEAK DETECTION (DIAPHRAGM FAILURE DETECTOR)

### GENERAL DESCRIPTION

An ARO® diaphragm pump equipped with the ARO Diaphragm Failure Detector warns of a diaphragm failure by sensing the presence of liquid in the air chamber of the pump. This system uses a liquid sensor in each of the two air chambers which will send an output signal when fluid is detected.

### INSTALLATION AND WARNINGS

**NOTE: ALL WIRING MUST COMPLY WITH ALL LOCAL AND / OR NATIONAL ELECTRICAL CODES.**

- Electrical codes that apply must be strictly adhered to; failure to do so may lead to shock hazard or serious injury.
- Some local electrical codes may require the installation of rigid conduit.

- The diaphragm failure detector components must be installed by a qualified electrician in compliance with all national, state and local codes and regulations to reduce the risk of electrical shock or other serious injury during installation and operation.
- ARO is not responsible for accidents resulting from improper installation of components or hardware.
- **HAZARDOUS VOLTAGE.** Do not attempt any service without disconnecting all electrical supply sources.

### PART LIST / PE0XX-XXX-XXX-XXEX, PE0XX-XXX-XXX-XXLX

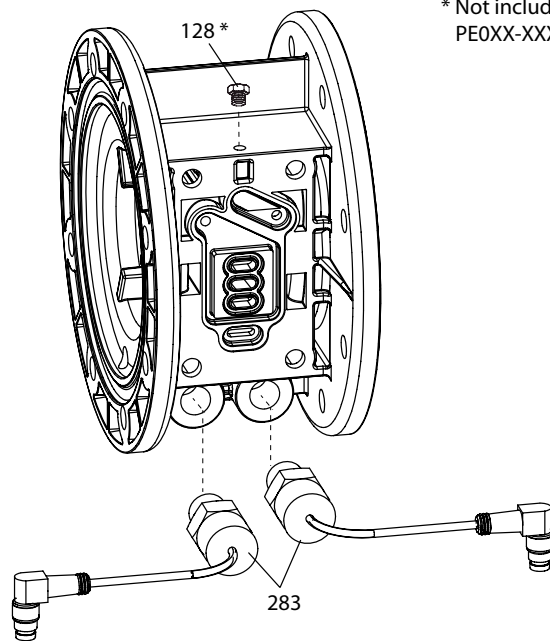

\* Not included with PE0XX-XXX-XXX-XXEX models.

Figure 6

### LEAK DETECTION (DIAPHRAGM FAILURE DETECTOR) - PINOUT DESCRIPTIONS

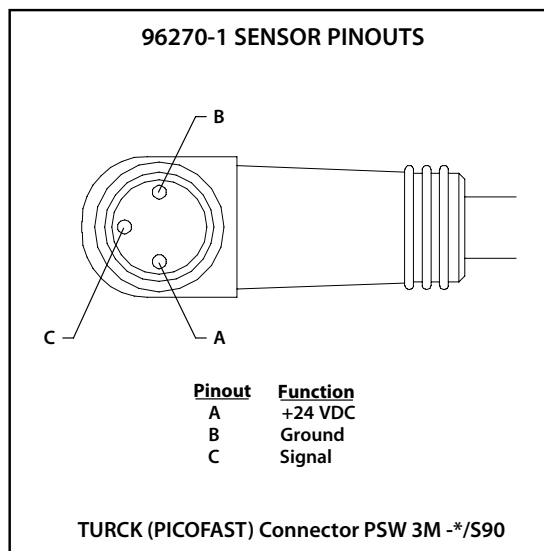

Figure 7

# CYCLE COUNTER

## GENERAL DESCRIPTION

The ARO diaphragm pump cycle counter provides a closed contact output each time the pump completes a cycle.

This signal may be used to record cycles for maintenance purposes or batching if the discharge volume of each complete cycle is known.

## PART LIST / PE0XX-XXX-XXX-XSXX

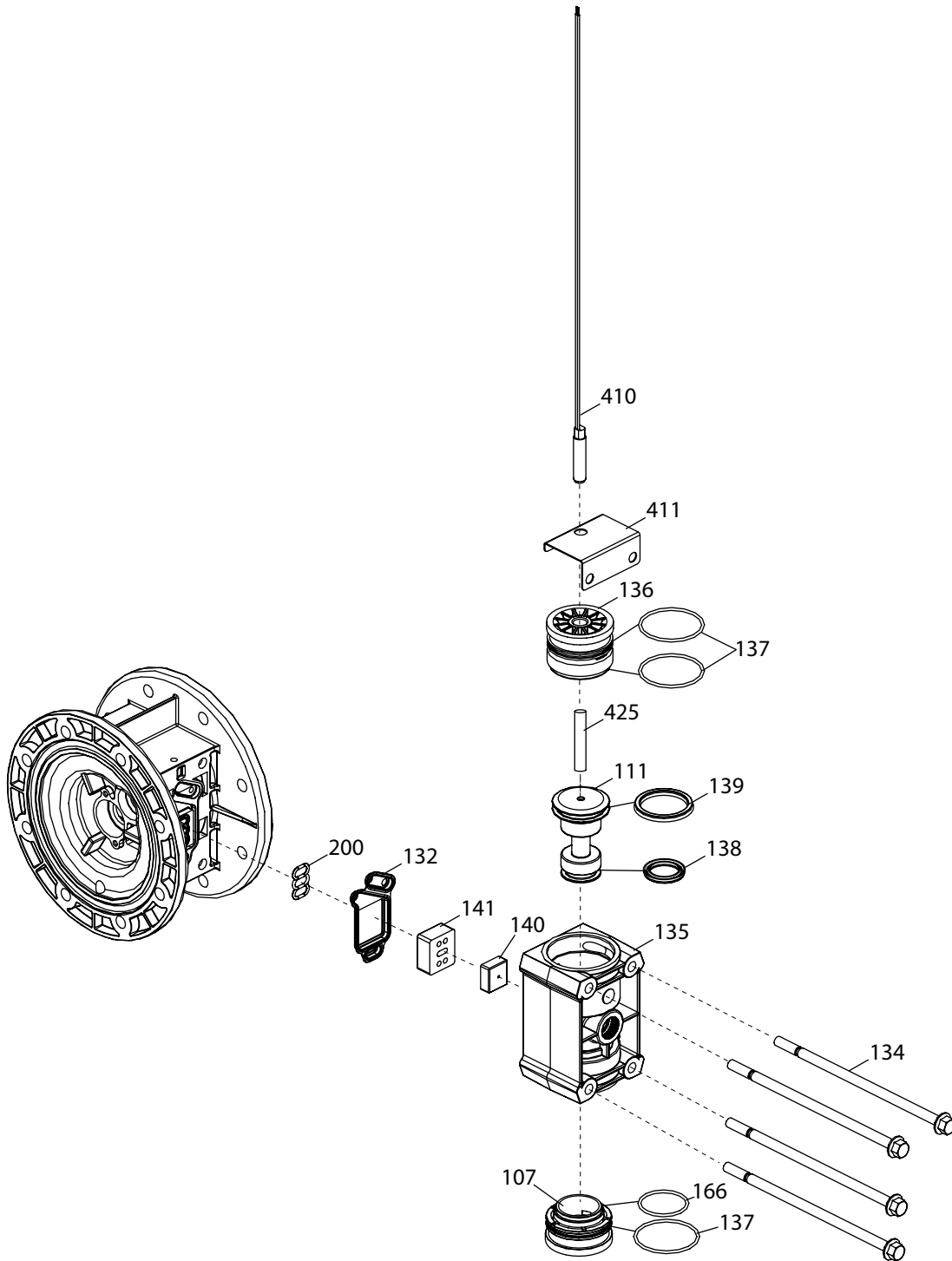

Figure 8

## OPERATION

Maximum Operating Voltage ..... 200 V DC  
Switching Current ..... 0.5 Amps  
The pump may be interfaced with a control device in the following ways:

As a SOURCING switch (see figure 1) for use with PLC's.  
As a SINKING switch (see figure 2) for use with PLC's.  
As a closed contact switch (see figure 3) for use with meters.

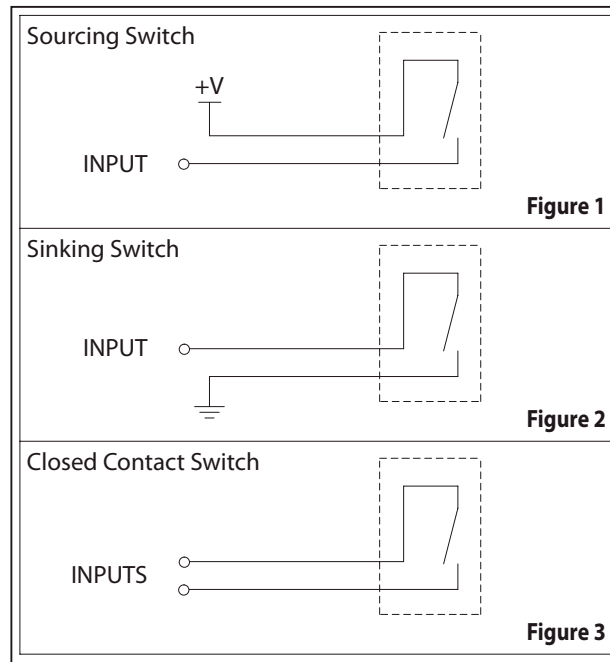
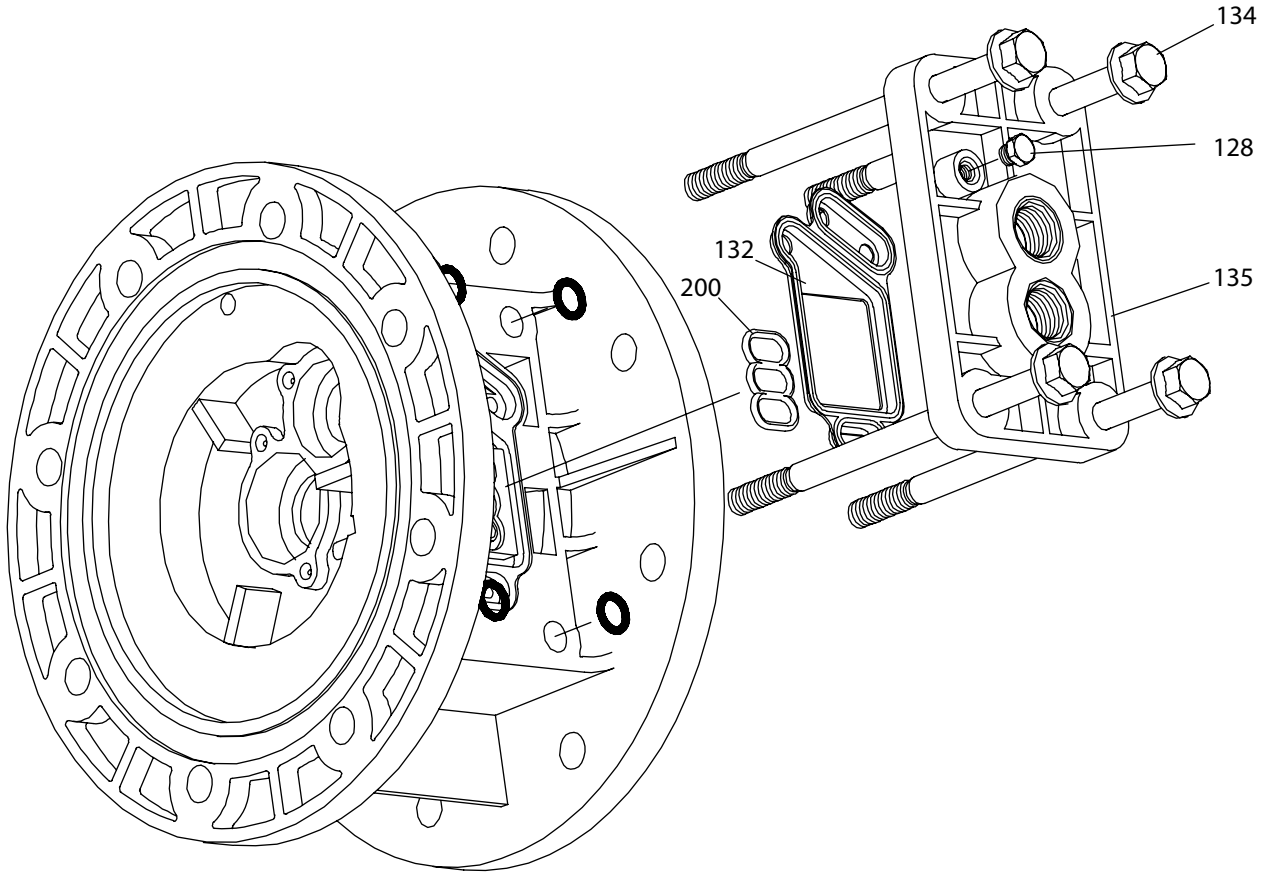

Figure 9





**Figure 10**





