

CALL TOLL FREE 877-742-2878 FOPR SALES AND SUPPORT

Return to BurtProcess.com

NETZSCH

Proven Excellence.



NEMO[®] Progressing Cavity Pumps

Comprehensive and superior solutions for all industries

Pumps & Systems

For six decades and at five sites worldwide, NETZSCH has been developing and producing high quality, innovative pump systems supported by a great number of patents. NETZSCH has manufactured over 1,000,000 progressing cavity pumps.

Good reasons

for choosing NEMO® Progressing Cavity Pumps

Benefit to the customer

Always focused on benefit to the customer, the NETZSCH product range covers everything from the smallest metering pumps with flow rates of a few ounces (milliliters) per minute to high-performance pumps that pump up to 4,400 gpm (1,000 m³/h). We also supply grinders and a comprehensive range of accessories. We supply everything in and around the pump to suit your application perfectly, because we understand and know your process.

Proximity to our customers

We guarantee proximity to our customers with more than 30 branches and 130 agencies around the world. Our application-oriented organizational structure across six business fields ensures that each of your contacts at NETZSCH® has detailed knowledge of the application, that national and international standards are complied with, and that contact routes are short, delivery is fast and on-site service is knowledgeable.

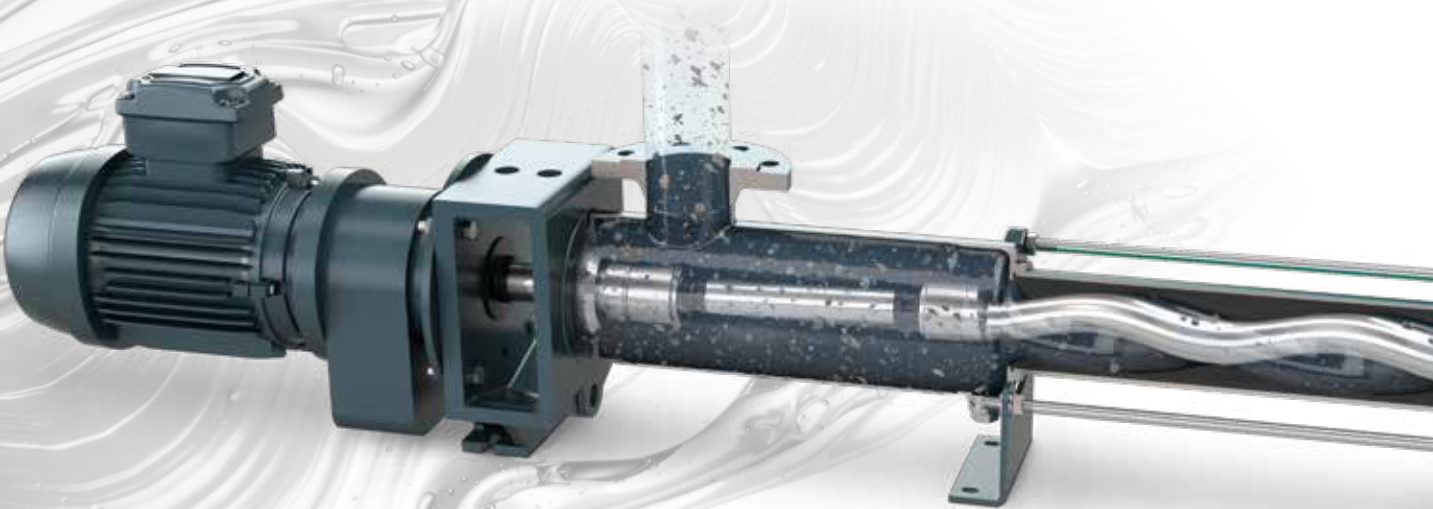

Individual pump selection

Each individual pump is precisely tuned to the requirements of the application to deliver optimum performance, service life and reliability.

Our pumps are available with conveying elements in four different rotor/stator geometries, so that the right solution can always be found for your application.

Another benefit from our continued investment in product development is a range of joints selected to suit each and every application no matter how demanding.

Lastly, we supply a comprehensive range of options and accessories, as well as expert service. We want you to stay in close contact with NETZSCH even after your pump has been commissioned.

Contact us and see for yourself.

Large capacity and pressure range

- Flow rates from just a few gph up to 4,400 gpm / a few ml/h up to 1,000 m³/h
- Number of stages ranging from 1 to 8 for pressures up to 720 psi / 50 bar (standard) or up to 4,350 psi / 240 bar (high pressure)

Broad range of applications

NETZSCH pumps are primarily used with product that has the following features:

- Free of solids to containing solids (max. solid size up to 6" / 150 mm)
- Low to high viscosity (1 cst to 10 million cst)
- Thixotropic and dilatant
- Shear sensitive or not
- Abrasive or non abrasive
- Non lubricating and lubricating
- Corrosive (pH 0 – 14)
- Adhesive
- Toxic

Wide range of materials

Our range of metallic materials extends from simple grey cast iron and chrome-nickel steel to highly acid-resistant materials such as Duplex, Hastelloy and titanium for different conveying tasks. Ceramics and plastics are offered for aggressive and abrasive applications. Our elastomers range from highly abrasion-resistant natural rubber, to oil-, acid- and alkali-resistant elastomers as well as Aflas and Viton. For products in which elastomers cannot be used because of high temperatures or for reasons of durability, a substantial number of solid-based stators made from PTFE or metallic materials are available.

(See pages 28 to 29)

Various conveying elements

Four different rotor/stator geometries are available to ensure the design is optimally adapted to your specific task.

(See page 26 and 27)

Great variety of shaft seals

The range of mechanical shaft seals includes simple seals with and without quench, double-acting seals arranged back to back or in tandem, and cartridge seals. For specific applications, stuffing-box packing, lip seals and special seals are available. A pump with magnetic coupling is available for use with toxic product – for the greatest assurance there are no leaks.

(See pages 32 and 33)

Additional features

- High suction capacity - up to 30 ftwc / 9 mwc
- Direction of rotation and flow can be reversed
- Can be installed in any position
- Quiet, smooth running
- Temperatures from -5 °F to 570 °F / - 20 °C to + 300 °C



Design of the NEMO[®] Pump

1 Rotor

From wear- and corrosion-resistant metal designs to the wear-free ceramic rotor NEMO CERATEC[®]. Wide range of coatings for abrasive fluids handling.

2 Stator

We manufacture stators to the latest standards. Minimized tolerance ranges thereby optimize the performance and efficiency of the pump. Our unique, fully networked production and process data monitoring system, developed in-house, is backed up by consistent quality testing. Every single stator is tested and measured; the data are recorded and traceable for each stator.

2.1 Stator with conventional technology

The stator is vulcanized into the tubes with integrated seals on both ends. The stator is available in a wide variety of NEMOLAST[®] elastomers, plastics and metals. Stator inlet with cone-shaped opening to improve product feeding into the conveying chamber and to optimize pump efficiency.

(see pages 28 and 31)

2.2 Stator with iFD[®] technology

The stator consists of a reusable two-part stator housing and an exchangeable elastomer part. The benefits of the new technology are reduced starting torques, higher degree of efficiency, prolonged lifetime, easier and faster wear part changes and environmentally friendly disposal.

iFD-Stator[®] Technology is available for 021 to 063 sizes in 01L and 02S geometries.



3 Drive train

The drive- and connecting shaft with coupling rod and two oil-filled universal joints provide the power transmission from the drive to the rotor. Low angularity guarantees longevity. Several types of joints available for different applications.

4 Shaft sealing

Standard design with single-acting, wear-resistant, bi-directional mechanical seals. On request, single-/ double-acting mechanical seals from a range of manufacturers, as well as cartridge and special seals and stuffing-box packing. The NEMO[®] NM range is the only PC pump on the market truly designed and optimized for mechanical seals.

5 Suction and discharge housing

Hydrodynamic design with flange (ANSI), thread (NPT) or sanitary (Tri-clamp) connections in accordance to all relevant standards. Grey cast iron, stainless steel 316, rubber-lined or Halar[®]-coated cast iron and special materials as per requirements. Drains, inspection ports and plugs for pressure sensors are available.

Halar[®] is a registered trademark of Solvay Solexis



NEMO® BY Industrial block pump



Optional: iFD-Stator® 2.0
Available for sizes NM021 to NM063
in 01L and 02S geometries.
Patented design.

6 Block design

As the drive is directly flanged onto the pump's pedestal, the dimensions are compact and the overall weight is low. The shaft heights are constant irrespective of the design and size of the drive – the pump requires low maintenance, is easy to maintain and is very economical.

NEMO[®] Industrial Pumps

NEMO[®] progressing cavity pumps are used in all sectors of industries to convey almost all types of product continuously, smoothly, with low pulsation and metering in proportion to speed.

NEMO[®] BY

block design



Performance

Flow rates up to 1,800 gpm / 400 m³/h at pressures up to 360 psi / 24 bar.

Fields of application

Waste water treatment plants, viscous to non-viscous chemical and petrochemical, pulp and paper, biomass and food industries.

Features

Compact design with directly flanged drive. Its low investment, operating and maintenance costs really make it stand out. Four rotor/stator geometries for optimum performance with every kind of application.

Additional information

NEMO[®] BY Pump Single Sheet 305-4

NEMO[®] SY

bearing housing design



Performance

Flow rates up to 2,200 gpm / 500 m³/h at pressures up to 680 psi / 48 bar (standard) or up to 4,350 psi / 240 bar (special applications).

Fields of application

Waste water treatment plants, viscous to non-viscous chemical and petrochemical, pulp and paper, biomass and food industries. Mining, oil and gas industry (including multiphase applications).

Features

Design with bearing housing and two-part shaft allows all types of drive and mechanical seals to be used universally and makes servicing the rotating parts simple and fast. Four rotor/stator geometries for optimum performance with every kind of application.

Optional: available with auger on the coupling rod (pictured) for high consistency fluids.

NEMO® BY Mini

block design



Performance

Flow rates from 0.3 to 150 gph / 1.1 to 567 l/h at pressures up to 180 psi / 12 bar — standard, and 500 psi / 36 bar — special.

Fields of application

Chemical metering in general industry, pharmaceutical, food industries, waste water plants, pulp and paper industries, and in laboratory application.

Features

The compact design with directly flanged drive and a broad range of construction materials, is offered with stainless steel 316 as standard. These pumps provide almost pulsation-free dispensing with high repeatability and a dosing accuracy of $\pm 1\%$. Four different (dimensionally identical) rotor/stator geometry sizes allow for easy adaptation of flow and pressure to meet your process requirements.

NEMO® Mini Hybrid

block design

Performance

Flow rates from 0.3 to 150 gph / 1.1 to 567 l/h at pressures up to 180 psi / 12 bar — standard, and 500 psi / 36 bar — special.

Fields of application

Chemical metering in general industry, pharmaceutical, food industries, waste water plants, pulp and paper industries, and in laboratory application.

Features

This pump fits into the upper range of our MINI pump line with a larger suction inlet and discharge port with 1-1/4" connections for highly viscous products, but still has the compact design. It also provides almost pulsation free dispensing with high repeatability and a metering accuracy of $\pm 1\%$. Four different (dimensionally identical) rotor/stator geometry sizes allow for easy adaptation of flow and pressure to meet your process requirements. Optional: available vertically positioned gear motor to reduce foot print.



NEMO[®] Industrial Hopper Pumps

We provide you NEMO[®] progressing cavity pumps in diverse designs and materials, designed according to the application. Low viscosity and also abrasive products are reliably conveyed using our pumps (BY and SY) with flanged connections.

For products with a very dry material content, such as de-watered sludge, different designs of NEMO[®] hopper pumps with auger feed systems are available including pumps with our patented aBP-Module[®] to prevent bridging.

* Technical notes: the hopper dimensions of all hopper pumps — except the BS — can be customized to suit the specific application.

NEMO[®] BS

block design with directly flanged drive and square open hopper or as NEMO[®] SS with bearing housing design



Performance

Flow rates up to 500 gpm / 115 m³/h at pressures up to 270 psi / 18 bar.

Fields of application

Industrial applications for high consistency fluids in waste water plants, the food industry and chemical industry for viscous to non-free flowing product with and without solids. Typically used for thickened sludge with up to 10% DS.

Features

Cast iron housing with square feed hopper and coupling rod with auger and compression chamber for improved product feeding into the conveying elements.

Additional information

NEMO[®] BS Open Hopper Pump
Single Sheet 305-8

NEMO® BO

block design with rectangular open hopper and force feed chamber or as NEMO® SO with bearing housing design



Performance

Flow rates up to 880 gpm / 200 m³/h at pressures up to 360 psi / 24 bar.

Fields of application

Industrial applications for high consistency fluids in waste water plants, the food industry and the chemical industry for viscous to non-free flowing product with and without solids. Typically used for dewatered sludge up to 15% DS or in the Food and Beverage Industry for spent grain.

Features

The housing with rectangular feed hopper and coupling rod with conveying screw and a compression chamber provide improved product feeding into the conveying elements.

Additional information

NEMO® BO Open Hopper Pump
Single Sheet 305-7

NEMO® BF

in block design with open hopper and force feed chamber or as NEMO® SF with bearing housing design



Performance

Flow rates up to 880 gpm / 200 m³/h at pressures up to 720 psi / 48 bar.

Fields of application

Industrial applications for high consistency fluids in waste water plants, the food industry, mining, chemical industry for highly viscous, compacted and crumbly product. For product that tend to bridge, the pump is fitted with the optional aBP-Module®. Typically used for dewatered sludge up to 35% DS.

Features

Housing with enlarged, rectangular feed hopper and with removable, cone-shaped force-feed chamber. Coupling rod with patented, positioned auger for optimal product feeding into the conveying elements.

Additional information

Sludge Cake Brochure
Brochure NPA 312

NEMO® BF Open Hopper Pump
Single Sheet 305-6

NEMO® BF optional aBP-Module® bridge breaking design

block design with directly
flanged drive or as
NEMO® SF with bearing
housing design



Performance

Flow rates up to 880 gpm / 200 m³/h at pressures up to 720 psi / 48 bar.

Fields of application

Industrial applications for waste water plants, the food industry, paper, mining, and chemical industry for highly viscous, compacted and crumbly product. For product that tend to bridge, the pump is fitted with the optional aBP-Module®.

Features

Housing with enlarged, rectangular feed hopper and with removable, cone-shaped compression chamber, coupling rod with patented, horizontally positioned conveying screw for optimum product feeding into the conveying elements.

Additional information

aBP-Module® Brochure
NPA · 070

NEMO® BP with bridge breaking design

block design with directly
flanged drive or as
NEMO® SP with bearing
housing design optional



Performance

Flow rates up to 880 gpm / 200 m³/h at pressures up to 720 psi / 48 bar.

Fields of application

Industrial applications in waste water plants, the food industry, mining, paper and chemical industry for compacted, lumpy and crumbly product that tends to bridge.

Features

Housing with integrated bridge breaker to prevent bridging and to mix in additives, enlarged rectangular feed hopper and removable, cone-shaped compression chamber, coupling rod with patented, horizontally positioned conveying screw for optimum product feeding into the conveying elements.

NEMO® Progressing Cavity Pumps designed for special applications

NEMO® B.Max® BM for the Biogas Industry

block design with directly flanged drive or as NEMO® B.Max® SM with bearing housing design



Performance

Flow rates up to 308 gpm / 70 m³/h at pressures up to 720 psi / 48 bar.

Fields of application

Applications in the biogas industry and farms for pumping and mixing the substrate (e.g. liquid manure) with organic material (biomass)

Features

Housing with large, rectangular feed hopper, coupling rod with patented, horizontally positioned conveying screw for optimum product feeding into the conveying elements. The additional, hydrodynamically designed flushing stud installed on the hopper housing ensures the substrates are fed and mixed optimally into the biomass. The NEMO® BY can be used to boost the substrate into the B.Max®.

Additional information

Biogas Brochure
NPA · 063

NEMO® Silo Pumps

NEMO® SF with bearing housing design



Performance

Flow rates up to 880 gpm / 200 m³/h at pressures up to 720 psi / 48 bar.

Fields of application

Industrial applications in waste water treatment plants for liquids with high content of solids in storage silos. The pump is installed below the silo and its enlarged open hopper receives the dewatered sludge and conveys it to incinerators, trucks or trains.

Features

Housing with enlarged, rectangular feed hopper compression chamber, coupling rod with patented, horizontally positioned conveying screw for optimum product feeding into the conveying elements. This model includes a barrier device to isolate the rotor/stator system to allow parts replacement even with solids in the storage silo.

„Full Service-in-Place“

Pump service without removing the pump from the system

The NEMO® Progressing Cavity Pump in FSIP® design is available...

- in sizes NM 045 to NM 105 for flow rates from 8 to 880 gpm / 2 to 200 m³/h
- for differential pressures up to 360 psi / 24 bar
- in various materials, from steel to stainless steel, various other materials on request
- with various stator elastomers, from highly abrasion-resistant natural rubber, to oil-, acid-, and alkali-resistant elastomers, to Aflas and Viton
- in all 4 geometries, S, L, D, and P to be customized optimally to your application

...and conveys

- substances with consistencies from runny to pasty, with or without solid content.

1 Housing in FSIP® design with inspection cover

The FSIP® design of the suction housing mainly differs from the standard design when you look at the new large inspection cover, but the housing dimensions remain unchanged. All installed NEMO® BY/SY pumps in the sizes mentioned above can be upgraded without complication. After this upgrade you can fully service the pump while it is installed. All wetted parts are immediately accessible. All wearing parts can be replaced in less than half the time.

2 Inspection cover

The inspection cover is fixed by only 5 screws which can be easily removed without special tools. A special seal between the housing and inspection cover guarantees the tightness of the housing.

3 Stator with iFD® technology

The iFD-Stator® consists of a two-part reusable housing with a polygonal profile and the NEMOLAST® elastomer housed within. The advantages of this new technology include a lower breakaway torque, higher efficiency, increased service life, simple and quick replacement, and environmental friendliness.

For Full Service-in-Place: *iFD-Stator® Technology is available for NM045 to 063 sizes in 01L and 02S geometries.*

(See brochure NPA · 344)

3 Stator with conventional technology (see page 15)

The stator inlet is vulcanized into the tubes with integrated seals on both ends. The inlets are available in a wide variety of NEMOLAST® elastomers, plastics and metals. Stator inlet with cone-shaped opening to improve product feeding into the conveying chamber.

(see pages 28 and 31)

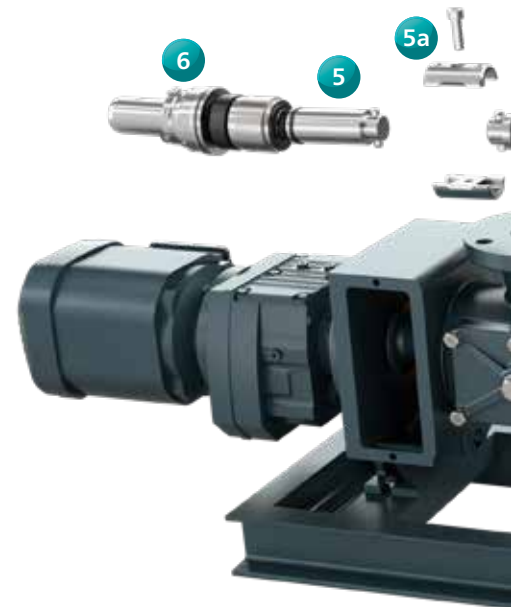



4 Rotor

In wear- and corrosion-resistant designs, various materials on request.

5 5a Drive train and sleeve coupling

Removing the inspection cover from the FSIP® pump you gain access to a sleeve coupling which joins the rotor to the coupling rod. Here only one screw has to be removed to split both elements from each other.

6 Shaft sealing

Standard for the FSIP® concept is a NETZSCH uNS-100 single acting mechanical seal with SIC/SIC faces, which can be easily removed through the large inspection opening. Other seal options upon request.

7 xLC® stator adjustment unit

The xLC® unit is attached to the stator and can compress or stretch it. In the case of wear, the elastomer part of the stator can be compressed to restore the pretension between the rotor and stator ensuring an efficient sealing line. This unit can extend the life of iFD-Stators® so that only the rubber insert needs to be replaced which will lower costs.

The xLC® unit requires the iFD-Stator® design technology.

NEMO® Progressing Cavity Pump in FSIP® Industrial Pumps

FSIP.ready, FSIP.advanced and FSIP.pro

Technology

The FSIP® design is fully compatible with the existing BY and SY series. The concept consists of three levels, FSIP.ready, FSIP.advanced and FSIP.pro, which are designed to upgrade already installed pumps step by step, or which are available for new installations according to the individual needs of our customers.



FSIP.ready

Pump including the revised housing design with large inspection cover, with standard drive train and various seal arrangements.



FSIP.advanced

Pump with new housing design having a large inspection cover, split coupling rod and various seal arrangements. Rotor and stator can be serviced in place.



FSIP.pro

Pump with new housing design having a large inspection cover that allows access and servicing in place of the split coupling rod, both joints, rotor, stator and a cartridge-design mechanical seal for "Full Service-in-Place".

NEMO® FSIP® Industrial Pumps

NEMO® FSIP® progressing cavity pump basic BY/SY pump including the revised housing design with large inspection cover, with standard drive train and with various seal arrangements.

NEMO® BY FSIP®

block design with standard stator



Performance

Flow rates from 8 to 880 gpm / 2 to 200 m³/h at pressures up to 360 psi / 24 bar. Pump sizes NM045 to NM105.

Fields of application

Industrial applications in environmental technology and in the food, oil and chemical industries for fluid to viscous product with and without solids.

Features

This is the entry model of our FSIP® line. It includes the basic NEMO® BY features and compact design but has the revised housing configuration with large inspection cover, standard drive train, various seal arrangements and a standard stator. This model can be upgraded to the FSIP.advanced or FSIP.pro.

NEMO® SY FSIP®

bearing housing design



Performance

Flow rates from 8 to 880 gpm / 2 to 200 m³/h at pressures up to 360 psi / 24 bar. Pump sizes NM045 to NM105.

Fields of application

Industrial applications in environmental technology and in the food, oil and chemical industries for fluid to viscous product with and without solids.

Features

This is the entry model of our FSIP® line. It includes the basic NEMO® SY features and flexibility of different types of drives, but also includes the revised housing configuration with large inspection cover, standard drive train, various seal arrangements and a standard stator. This model can be upgraded to FSIP.advanced or FSIP.pro.

NEMO® SY FSIP® in Stainless Steel

bearing housing design or as
NEMO® BY block design

Performance

Flow rates from 8 to 880 gpm / 2 to 200 m³/h at pressures up to 360 psi / 24 bar. Pump sizes NM045 to NM105.

Fields of application

Industrial applications in environmental technology and in the food, oil and chemical industries for fluid to viscous product with and without solids.

Features

Stainless steel housing and discharge flange provides chemical resistance for aggressive environments and fluids. This FSIP.ready pump is the entry model of FSIP® line. It includes the basic NEMO® SY features and flexibility of different drive types, but has the revised housing design with large inspection cover, standard drive train, various seal arrangements and a standard stator.



NEMO® FSIP® Industrial Hopper Pumps

We provide NEMO® progressing cavity pumps in diverse designs and materials, designed according to the application. Low viscosity and abrasive sludge is reliably conveyed using our pumps with flanged connections.

For product with a very dry material content, such as de-watered sludge are available either for different designs of the NEMO® hopper pumps with screw conveyors or also with our aBP Module® to prevent bridging.

NEMO® BO FSIP® Design

block design with rectangular
open hopper and force
feed chamber or as
NEMO® SO with
bearing housing
design



Performance

Flow rates from up to 880 gpm / 200 m³/h at pressures up to 360 psi/ 24 bar.

Fields of application

Industrial applications in environmental technology and in the food, oil and chemical industries for fluid to viscous product with and without solids.

Features

Design includes direct flange drive, housing with rectangular feed hopper and large inspection cover, coupling rod with conveying screw and a compression chamber that provides improved product feeding into the conveying elements. This model can be upgraded to the FSIP.advanced or FSIP.pro.

NEMO® BF in FSIP® Design

block design with open hopper and force feed chamber or as NEMO® SF with bearing housing



Performance

Flow rates up to 880 gpm / 200 m³/h at pressures up to 720 psi / 48 bar.

Fields of application

Industrial applications in environmental technology, the food industry and the chemical industry for highly viscous, compacted and crumbly product.

Features

Housing design with enlarged, rectangular feed hopper has a removable, cone-shaped compression chamber. The design includes a coupling rod with patented, horizontally positioned conveying screw for optimum product feeding into the conveying elements. The maintenance-friendly design with discharge flange extension facilitates stator and rotating parts change out without the need to remove the discharge pipeline.

NEMO® Immersible Pumps

NEMO® Immersible Pumps are used to empty barrels, containers, tanks, sedimentation tanks, pits etc. and where space is restricted, there is a risk of cavitation or there is very low NPSH. The pumps are also used to empty containers holding materials that are hazardous to water or the environment for which standard emptying via a flange on the bottom of the container is not permitted.

NEMO® Immersible Pump BT

with suspension bracket

This pump is used to empty open barrels and containers. It is fitted with a clamp to be suspended from a crane. Immersion depth up to 10 ft / 3 m.

Performance

Flow rates up to 616 gpm / 140 m³/h at pressures up to 360 psi / 24 bar. Depending on the specific application, various models/immersion variants are available. The immersion depth is adapted specifically to the application.

Features

Compact design with directly flanged drive. Four rotor/stator geometries for optimum performance with every kind of application. Immersion depths up to 33 ft / 10 m. The immersion tube length can be modified by extending the pump housing, adding a suction pipe or by a combination of the two.

Additional information

NEMO® BT Immersible Pump
with Suspension Bracket Single
Sheet 305-10



NEMO® Immersible Pump BT

with integral mounting plate

Depending on pump size, speed and immersion depth up to 33 ft / 10 m, an additional support guide is available to secure the pump to the bottom or to the wall near the bottom. Removal of the pump from a full tank is possible because the guide units are self-centering and secure the pump suction without fixings. In the variant with discharge connection below the mounting position the discharge connection of the pump is below the tank lid. The product is either piped to the outside vertically through the lid via a 90° elbow or horizontally through the tank wall. This minimizes the dead space in the pump housing thus reducing the overall height of the pump above the tank lid.

Performance

Flow rates up to 616 gpm / 140 m³/h at pressures up to 360 psi / 24 bar.

Special designs for up to 1,000 psi / 68 bar are available.

Depending on the specific application, various models/immersion variants are available. The immersion depth is adapted specifically to the application.

Features

Compact design with directly flanged drive. Four rotor/stator geometries for optimum performance with every kind of application. Immersion depths up to 33 ft / 10 m. The immersion tube length can be modified by extending the pump housing, adding a suction pipe or by a combination of the two.



Additional information

NEMO® BT Immersible Pump
with Integral Mounting Plate
Single Sheet 305-11

NEMO[®] Sanitary Pumps

The pumps are designed and manufactured in accordance with QHD guidelines, are CIP/SIP-capable and most of them comply with the US 3-A Sanitary Standards. Two rotor/stator geometries* are available to ensure optimum performance.

These pumps are suited for hygienic applications in the foodstuffs, pharmaceutical, cosmetic and biotechnology industries for low and highly viscous product with and without solids.

*excluding NEMO[®] Mini BH

NEMO[®] BY Sanitary Prime

FDA compliant solution for sensitive, abrasive and high viscosity pumping requirements



Performance

Flow rates up to 880 gpm / 200 m³/h at pressures up to 360 psi / 24 bar.

Features

Continuous low pulsation conveyance unaffected by fluctuations in pressure and viscosity. Conveyance volume is in proportion to rotation speed with high metering precision over the entire rotational speed range. High pressure capability without valves. The robust design is compact and in block construction. Wetted surfaces are polished. Externally blasted surfaces. Centered suction tri-clamp.



Additional information

NEMO[®] BY Sanitary Prime Pump
Single Sheet 308-3

NEMO® BH Sanitary Advanced Pump

Sanitary design pump for sensitive, abrasive and high viscosity pump requirements



Performance

Flow rates up to 200 gpm / 45 m³/h at pressures up to 360 psi / 24 bar.

Features

This pump offers continuous low pulsation conveyance unaffected by fluctuations in pressure and viscosity. All wetted parts are in 316 stainless steel and are polished to 32 micro inch Ra. Available with CIP ports (Standard or tangential arrangement). Patented hygienic joint. Discharge at the lowest point to ensure optimal drainability. Mechanical seal directly in the flow path for superior cleaning. Tangentially positioned suction port allows for optimal flow and swirling motion for improved cleanability.



Additional information

NEMO® BH Sanitary Advanced-Pump Single Sheet 308-1

NEMO® SH Sanitary Advanced Plus Pump

Sanitary Pump with joint free design



Performance

Flow rates up to 620 gpm / 140 m³/h at pressures up to 360 psi / 24 bar.

Features

This pump has a single piece rotor and connecting rod, joint free design, and elimination of product retention areas. All wetted parts are in 316 stainless steel and are polished to 32 micro inch Ra, externally polished. The design with bearing housing and drive shaft allows use with all types of drives. Crevice free and maintenance free flexible rod design. Available with CIP ports (standard or tangential arrangement). Discharge is at the lowest point to ensure optimal drainability. Tangential suction port provides an efficient flow.



* Recertification in progress

Additional information

NEMO® SH Sanitary Advanced Plus Pump Single Sheet 308-2

NEMO® BH Sanitary Advanced with heating Jacket

Sanitary Pump with full heating jacket

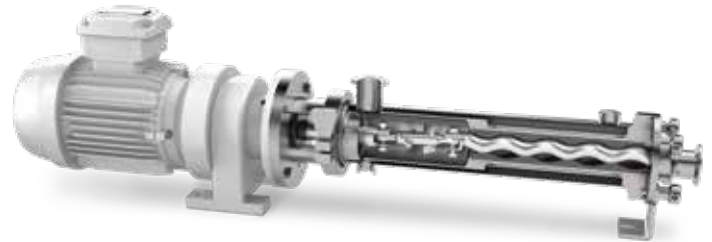

Performance

Flow rates up to 176 gpm / 40 m³/h at pressures up to 180 psi / 12 bar.

Features

This pump is suitable for all sanitary applications in the food, pharmaceutical, cosmetic, and biotechnology industries, especially for viscous product which have to be heated or cooled. This pump operates reliably and guarantees your process: the specially designed mechanical seals are arranged with no dead spaces; the housing and stator are heated; the products are conveyed smoothly; and the pump can be easily cleaned. Quick-fit connections make disassembly for maintenance simple. This pump is available with various rotor/stator geometries. It has open sanitary pin joints, exposed housing seals, mixing elements on the coupling rod, and a heating jacket over the entire length of the stator and pump housing. All surfaces that come in contact with the product are polished to prevent deposit formation and to facilitate cleaning.



NEMO® BH Sanitary Mini Advanced Plus

Sanitary mini pump with joint free design

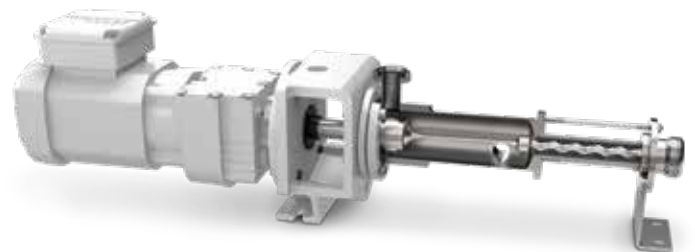

Performance

Flow rates from 0.02 up to 130 gph / 0.1 up to 500 l/h at pressures up to 520 psi / 36 bar.

Features

The flexible rod has no dead space and is wear- and maintenance-free so that it can be used even with highly sensitive and with abrasive products. This pump has high metering accuracy (deviation of < 1%). The compact design with directly flanged drive delivers low investment, operating and maintenance costs.



NEMO® BO Sanitary Prime Open Hopper Pump

block design with directly flanged drive or as NEMO® SO with bearing housing design



Performance

Flow rates up to 880 gpm / 200 m³/h at pressures up to 360 psi / 24 bar.

Fields of application

Industrial applications in the beverage, food, cosmetic, biotech and chemical industries for viscous to non-free flowing product with and without solids.

Features

Housing is designed with enlarged rectangular hopper, a force feed chamber and integrated feeding screw in the hopper. Continuous low-pulsation conveyance is unaffected by fluctuations in the pressure and viscosity.

Additional information

NEMO® BO Sanitary Prime Open Hopper Pump Single Sheet 308-5



NEMO® BH Sanitary Advanced Open Hopper Pump

block design with directly flanged drive or as NEMO® SO with bearing housing design

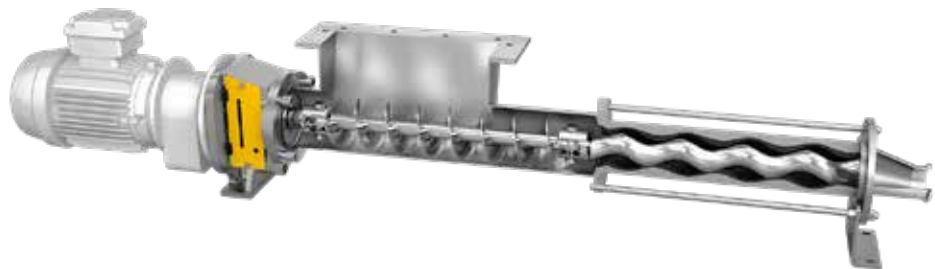

Performance

Flow rates up to 200 gpm / 45 m³/h at pressures up to 360 psi / 24 bar.

Fields of application

Industrial applications in the beverage, food, cosmetic, biotech and chemical industries for viscous to non-free flowing product with and without solids.

Features

Open hygienic joint. Housing designed with enlarged rectangular hopper, a force feed chamber and integrated feeding screw in the hopper. Continuous low-pulsation conveyance unaffected by fluctuations in pressure and viscosity.

Additional information

NEMO® BH Sanitary Advanced Open Hopper Pump Single Sheet 308-4



NEMO® SA

Aseptic pump

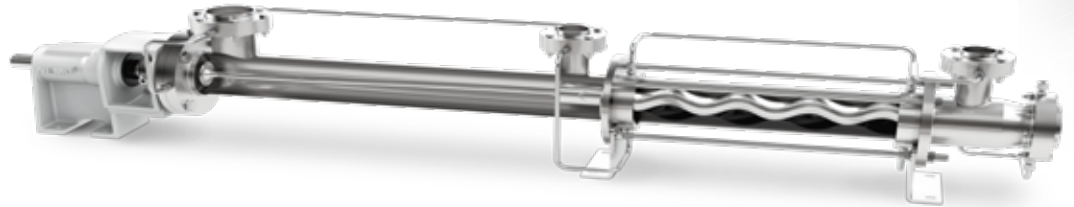

Performance

Flow rates up to 620 gpm / 140 m³/h at pressures up to 360 psi / 24 bar.

Features

The flexible rod is free of dead space and is wear- and maintenance-free so that it can be used even with highly sensitive and abrasive products. The pump housing has a reduced diameter and a product inlet displaced towards the shaft sealing (outlet in vertical installation). The pump chamber is therefore completely free of dead space and the flow of the product through the pump is also optimized. The cleaning ports are arranged tangentially and pressure port eccentrically for residue-free self-emptying. All sealing points are designed for steam or sterile condensate and the pipe work is installed ready for use to prevent contamination from the environment. As standard, the stator is supplied with reduced elastomer wall thickness for use at varying product temperatures and with a stator protector to prevent dry running and overheating. The design with bearing housing and drive shaft allows use with all types of drives.



NEMO® BO Cutter Pump

block design with directly flanged drive



Performance

Flow rates up to 880 gpm / 200 m³/h at pressures up to 360 psi / 24 bar.

Fields of application

Industrial applications in chemical and food industries for fluid to viscous product with solids. Pump was developed to enable conveying and cutting in one process step.

Features

The housing design includes a rectangular feed hopper, coupling rod with conveying screw and compression chamber. The cutting system found in the compression chamber and at the discharge of the pump will chop the solids into smaller pieces.



Additional information

Cutter Pump Flyer 314

NEMO® NBE Drum Emptying Unit

The heart of the NETZSCH NBE Drum Emptying Unit is its NEMO® progressing cavity pump which creates positive displacement, low pulsation flow to convey your product with out damage. In fact, most products are only exposed to the friction loss through the discharge piping. The NETZSCH single side rail system raises and lowers the follower plate safely while providing a simple and easy structure to clean.

NEMO® NBE Drum Emptying Unit

with choice of pump for your industrial, Sanitary or Hygienic application

Performance

Flow rates up to 44 gpm / 10 m³/h at pressures up to 290 psi / 20 bar. Available with BY Industrial pump, BY Sanitary Prime Pump and BH Sanitary Advanced Pump

Fields of application

Applications in the food industry, cosmetic, pharmaceutical, chemical and bio industries, silicone, caulk and sealants.

Features

It is possible to empty drums, in several sizes, bins or special geometry barrels. Continuous or intermittent emptying of your drum with less than 1% left in the container. No pressure or flow interruption, emptying of conical drums is optional. Low pressure conditions in the entire system. Continuously adjustable discharge capacity.



Additional information

NBE 200 Drum Emptying Unit
Single Sheet 331-200

Operating method and conveying principle in NEMO® PUMPS with different rotor/stator geometries

Modular system

NEMO® Pumps belong to the group of rotary positive displacement pumps. The two conveying elements are the rotor and the fixed stator, in which the rotor eccentrically turns.

As all four pump geometries have the same outer dimensions. We have a modular design where – apart from rotor and stator – all other components are identical. When a change in flow rate or pressure is required, installed NEMO® Pumps can be adapted to the new operating conditions by simply changing rotor and stator.



S Geometry

- Very smooth pumping
- Compact dimensions despite large number of stages
- Large rotor inlet cross-sections
- Low flow velocity/NPSH
- Pumps compacted products
- Pumps large solid particles

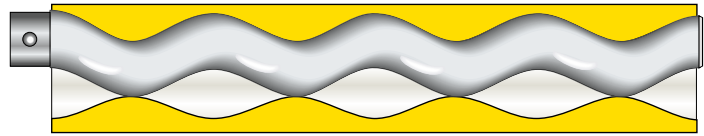
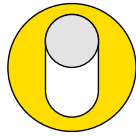

- 1/2 lobe
- Double stage
- Flow rate: 100%
- Differential pressure: 180 psi / 12 bar
- Multistage design available for pressures up to 4,350 psi / 300 bar

L Geometry

- Good volumetric efficiency/long service life thanks to long seal line between rotor and stator
- Compact dimensions with high flow rates



- 1/2 lobe
- Single stage
- Flow rate: 200%
- Differential pressure: 90 psi / 6 bar

D Geometry

- Very compact dimensions despite high pressures and flow rates
- Almost pulsation-free pumping
- High metering accuracy



- 2/3 lobe
- Double stage
- Flow rate: 150%
- Differential pressure: 180 psi / 12 bar
- Multistage design available for pressures up to 4,350 psi / 300 bar

P Geometry

- Compact dimensions in conjunction with very high flow rates
- Almost pulsation-free pumping
- High metering accuracy
- Good volumetric efficiency/long service life thanks to long seal line between rotor and stator



- 2/3 lobe
- Single stage
- Flow rate: 300%
- Differential pressure: 90 psi / 6 bar



Testing properties and quality

NEMOLAST®

elastomer quality developed,
continuously tested and
optimized at NETZSCH



Developing new blends



Manufacturing blends

Development

Elastomer research & development and manufacturing of compounds is in-house at NETZSCH. At its in-house laboratory and in close collaboration with selected materials suppliers established over many years, NETZSCH develops and tests elastomer blends and optimizes them for the specific requirements of customers.

We therefore offer each customer the optimum quality of elastomer for the product to be conveyed in terms of abrasion resistance, temperature range, dynamic load and chemical resistance – something other suppliers cannot offer. Only using original NETZSCH spare parts guarantees our pumps remain reliable.

Production

60 years of experience in a wide range of industries and processes and 40 years of experience developing and manufacturing elastomers for NEMO® pumps led up to the development of complex bonded parts made of glass fiber, metal and elastomer for the casing liners of our new generation of TORNADO® T2 rotary lobe pumps.

To meet the constantly growing demand for our pumps and the associated demand for spare parts, NETZSCH invested in new production facilities in Waldkraiburg, Germany and in Pomerode, Brazil to produce elastomer parts using the latest production methods and the latest product standards. Alongside five extruder sets to manufacture conventional tube stators, injection molding machines and presses were also acquired to manufacture iFD-stators®, lobes and casing liners for rotary lobe pumps.

Specific requirements in oil production and transfer

This applies in particular to the difficult operating conditions in oil production. NETZSCH stators stand out with their long service life, leading to a significant reduction in operating costs.

Both for elastomer development as well as for optimal material selection the specific bore hole and fluid conditions have to be considered. NETZSCH pumps are used as multiphase pumps, which means that gas-oil-water mixtures and various solids are conveyed simultaneously or alternately.

Therefore, we have developed special elastomer mixtures, for conveying these phases in changing and variable concentrations. Additional challenges to the material are the fluctuating and sometimes very high temperatures and the high differential pressure—up to 4,350 psi / 300 bar between the suction and pressure side. Very aggressive gases (such as H₂S and CO₂) or oils (with high aromatic content) can also be present.



Extruder with stator for oil production



Press with casing liners for TORNADO® T2



Injection molding machine for iFD-stators®

	NEMOLAST® – stator qualities for industrial and sanitary applications				
Material description/ NEMOLAST® Code	11	31	43	46*2)	61T
Color	black	black	white	black	black
Base polymer	Natural rubber/ butadiene rubber (NR/BR)	Chlorinated polyethylene (CM)	Ethylene propylene diene rubber (EPDM)	Ethylene propylene diene rubber (EPDM)	Hydrogenated acrylonitrile butadiene rubber (HNBR)
Aging resistance	0	++	+	+	++
Ozone resistance	-	++	+	++	++
Petrol resistance	--	--	--	--	0
Oil and fat resistance	--	-	--	--	++
Acid resistance	0	++	0	+	0
Alkali resistance	0	++	0	+	0
Hot water	0	+	+	+	0
Min. operating temperature	-4 °F / -20 °C	14 °F / -10 °C	-4 °F / -20 °C	-13 °F / -25 °C	23 °F / -5 °C
Max. operating temperature	194 °F / +90 °C	230 °F / +110 °C	212 °F / +100 °C	226 °F / +130 °C	284 °F / +140 °C
Abrasion resistance mm ³	<40	<90	<320	<130	<40
Abrasion resistance	++	++	0	+	++
Hardness range (shore)	64 ± 5	73 ± 5	70 ± 5	70 ± 5	73 ± 5
FDA	no	no	no	yes	no
Nitrosamine-free	no	no	no	yes	no

NEMOLAST® stator qualities for oil production and transfer

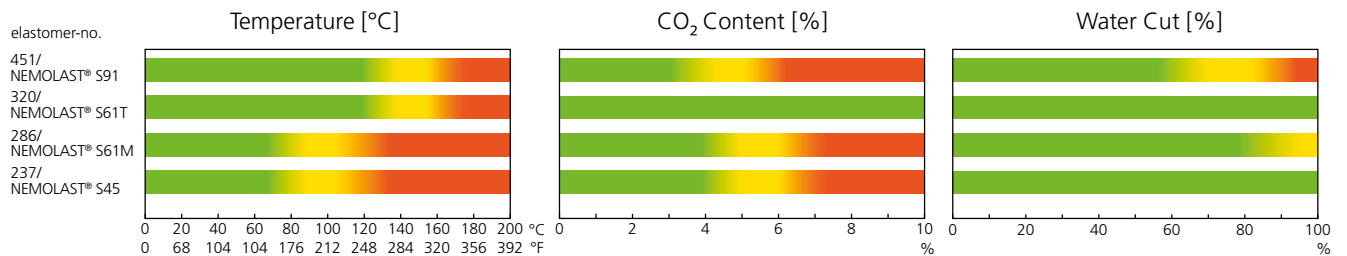

					Solid Stators	
62L*2)	65L*1)	66L*2)	85	91*2)	teflon	cast iron**3)
black	black	black	opaque	black	white	grey
Acrylonitrile butadiene rubber (NBR)	Acrylonitrile butadiene rubber (NBR)	Acrylonitrile butadiene rubber (NBR)	Silicone rubber (SI)	Fluororubber (FKM FPM)	Polytetrafluoroethylene	Grey cast iron
0	0	0	+	++	++	For neutral product
-	-	-	+	++	++	
0	0	0	--	++	++	
+	+	+	+	++	++	
0	0	0	--	++	++	
0	0	0	+	++	++	
0	0	0	+	++	++	
23 °F / -5 °C	23 °F / -5 °C	23 °F / -5 °C	-40 °F / -40 °C	23 °F / -5 °C	-4 °F / -20 °C	-4 °F / -20 °C
212 °F / +100 °C	212 °F / +100 °C	212 °F / +100 °C	302 °F / +150 °C	320 °F / +160 °C	320 °F / +160 °C	392 °F / +200 °C
<60	<70	<130	<60	<160	-	-
++	++	+	++	+	-	-
73 ± 5	70 ± 5	68 ± 5	65 ± 5	73 ± 5	-	-
no	yes	yes	yes	no	yes	-
yes	yes	yes	yes	no	-	-

*1) only for TORNADO® T2 rotary lobe pumps
 *2) also for TORNADO® T2 rotary lobe pumps
 *3) different solid stator materials on request

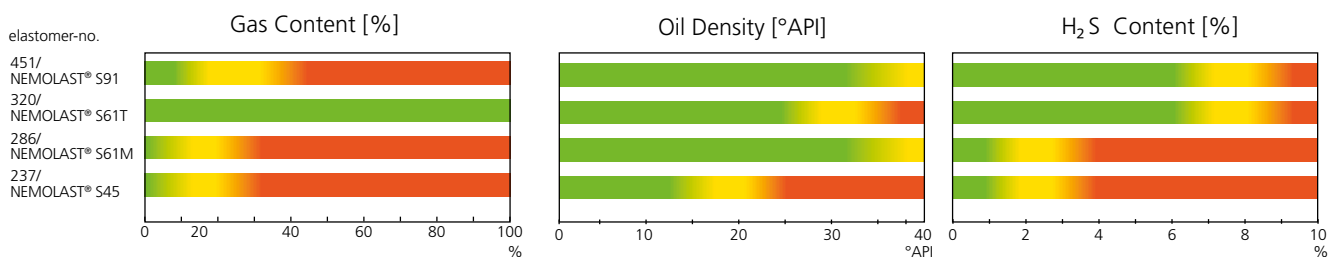

Please take into consideration that the given material limits are a guideline. The final selection has to be based on a detailed analysis (e.g. swelling test).

■ recommended range
 ■ caution range
 ■ not recommended

Having the right joint in your NEMO® pump has a decisive impact on operational reliability and life-cycle costs. The optimum joint is selected on the basis of the application, the operating conditions and the conveyed product. To achieve the optimum performance of a NEMO® pump, additional joint adaptations can be made to better address individual conditions.

The right NEMO® joint

FOR EVERY APPLICATION

B Universal Pin Joint

The NEMO® universal pin joint is the standard joint for NEMO® industrial pumps due to its simple design and outstanding degree of reliability. The joint has a very long service life, because it is oil-filled and sealed using a NEMO® SM® seal. The joint can also be used without a seal at extremely high temperatures and flow rates where elastomers are not suitable. The joint has a minimum number of components and can be easily dismantled for maintenance.

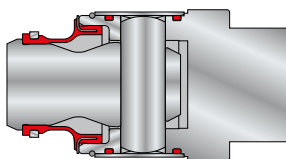

V Pin Joint

The operational characteristics of a NEMO® V pin joint are similar to those of the B pin joint, but it has a longer service life under tough operating conditions because of hardened bushings, which are fitted into boreholes in the coupling rod and the rotor/drive shaft head. It can be replaced easily during maintenance.

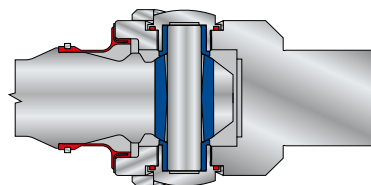

H Hygienic Pin Joint

This open, patented pin joint has been developed specifically for use in NEMO® hygienic pumps. The joint has no crevices or dead space. It is polished and easy to clean. The hygienic pin joint is designed in accordance with US 3-A Sanitary Standards.

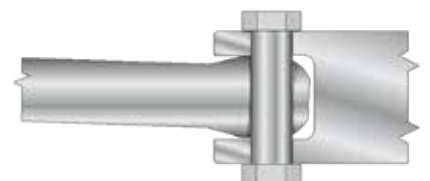



Flextec Flexible Rod

This flexible rod is wear- and maintenance-free, because there are no components moving against each other as in other joint types. Neither lubricants nor seals are required. The flexible rod is suitable for high ambient pressures and temperatures. It is free of crevices and dead space which allows the flexible rod to be used for pumping highly sensitive products in aseptic conditions. It is designed in accordance with the US 3-A Sanitary Standards.

K Joint

The patented, kinematically optimized design K joint was developed for highly demanding industrial applications. The torque and axial loads are shared by separate elements within the joint. The joint is oil lubricated and sealed hermetically by two joint seals that are resistant to/compatible with the lubricant and the pumped product. Filling the space between the two joint seals additionally with oil means that the joint can be used at ambient pressures of up to 180 psi / 12 bar. Specially designed gear joints with solid, massive rubber block are available to handle up to 360 psi / 24 bar suction pressure.

Z Double Seal Pivot Joint

For large flows and/or pressures (from size NM125SY upward), NEMO® industrial pumps are equipped with kinematic precision cartridge type double seal pivot joints, which have been designed with extremely high permanent loads, torques and axial forces in mind. The joint is oil lubricated and sealed hermetically by two joint seals that are resistant to/compatible with the lubricant and the pumped product. Special design with hydraulically balanced piston allows for suction pressure of up to 1,450 psi / 100 bar.

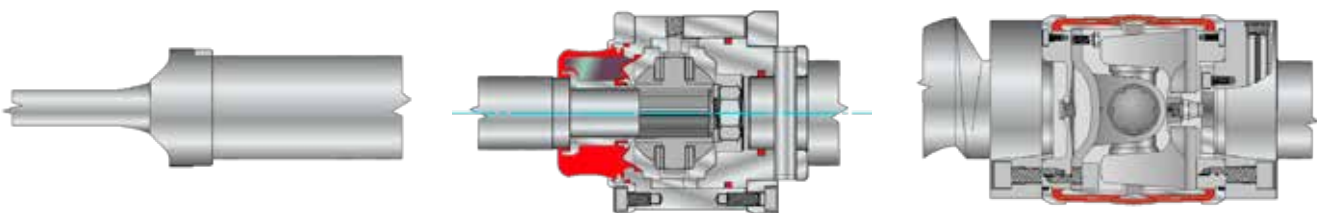

FROM A TO Z

Accessories & Service

Accessories to increase the operational safety of both pump and plant to prevent downtimes

Process monitoring

Dry running protectors safeguard elastomer parts of the pump against thermal damage and protect the pump.

- Dry running protection (STP3, STPA2A, STP2D)
- Flow sensors for solid stators
- Speed monitoring device

Overpressure and underpressure protectors safeguard the pump and protect downstream aggregates and valves against overpressure and underpressure.

- Diaphragm Pressure Gauge
- Pressure control device DTSL 3
- Multi-function pressure instrument
- By-pass line

Seal Support Systems

Additional flushing, quench or pressurized flushing systems that flush or close the seals with clean conveyed medium are often required to ensure shaft seals function correctly and reliably.

- Quench pot
- Permanent lubricator
- Pressurized flush for double mechanical seals

Tools and additional equipment

Many useful options are available to correctly maintain and smoothly operate your pumps.

- Gear joint filling unit
- Ring dosing nozzle
- Chemical anchor
- Stator removal tool

Protection Units and Carts

In all areas of production within the food, pharmaceutical and cosmetic industries, a range of optional parts are available to ensure uncompromising hygiene and to enable mobile use.

- Covers for drives
- Transport devices
- Machine feet - flexible, rigid

Additional information

Quickship Flyer NPA · 907

Customer Service / Aftermarket
Brochure NPA 400



NETZSCH Service

The benefit to you

Advice, service and quality are our strengths. Strict quality standards, test procedures and certification in accordance with DIN EN ISO 9001 guarantee that you receive the very highest quality without exception. To maintain the performance and quality of your pump, we continue to provide support after delivery in all aspects of your pump to ensure it operates reliably in your system. We have over 60 years with more than 1,000,000 installed pumps behind us.

QuickShip Program

Quick, easy, and convenient sizing and selection tool with a popular selection of BY pump

- The first and most distinctive program of its kind
- Pumps ship within 24- or 72- hours
- Use for quick budget pricing
- Pumps include gearmotors, first class mechanical seals and baseplates
- Material options and geometry options also available

The logo for QuickShip, featuring a stylized blue and green icon of three horizontal lines to the left of the word "QuickShip" in a bold, italicized, sans-serif font.

Spare Parts and Service

Our distributor / representative partners are available for quick and economic service of your pump at your site. You will find your local distributor / representative in the locator on our website at:

www.pumps.netzsch.com

or you can call our Customer Service team at:

1-610 363-8010 Exton
1-346 445-2400 Houston
1-705 797-8426 Canada

24 / 7 EMERGENCY HOTLINE:

For urgent spare parts needs or service issues, please call our **1-484-986-8480**





The NETZSCH Group is an owner-managed, international technology company with headquarters in Germany. The Business Units Analyzing & Testing, Grinding & Dispersing and Pumps & Systems represent customized solutions at the highest level. More than 4,000 employees in 36 countries and a worldwide sales and service network ensure customer proximity and competent service.

Our performance standards are high. We promise our customers Proven Excellence – exceptional performance in everything we do, proven time and again since 1873.

The NETZSCH Business Unit Pumps & Systems offers NEMO® progressing cavity pumps, TORNADO® rotary lobe pumps, NOTOS® multi screw pumps, PERIPRO™ peristaltic pumps, macerators/grinders, metering technology and equipment custom built for challenging solutions for different applications globally.

Proven Excellence.

NETZSCH Pumps USA
119 Pickering Way
EXTON, PA 19341-1393
USA
Tel.: +1 610 363 8010
Fax: +1 610 363 0971
npa@netzsch.com

NETZSCH Pumps USA
Houston
1511 FM 1960 Road
Houston, TX 77073
Tel.: +1 346-445-2400
npa@netzsch.com

NETZSCH Canada, Incorporated
500 Welham Road
Barrie, ON L4N 8Z7
Canada
Tel.: 705 797 8426
Fax: 705 797 8427
ntc@netzsch.com



NETZSCH®

pumps-systems.netzsch.com