

**STANDARD FEATURES:**

- PAINTED AIR MOTOR WITH MUFFLER
- HELICAL GEARBOX - 5:1 REDUCTION RATIO
- 350 RPM NOMINAL OUTPUT
- 55 GALLON DRUM LID WITH TWO STANDARD NPT PORTS
- 316SS WETTED PARTS
- 1" X 30" FMB SHAFT STANDARD
- SINGLE OR DUAL HYDROFOIL IMPELLERS WITH SET SCREW ATTACHMENT
- SPEED CONTROL VALVE

**OPTIONS:**

- FILTER, LUBRICATOR, AND REGULATOR (FLR)
- 32 Ra FINISH ON ALL WETTED PARTS

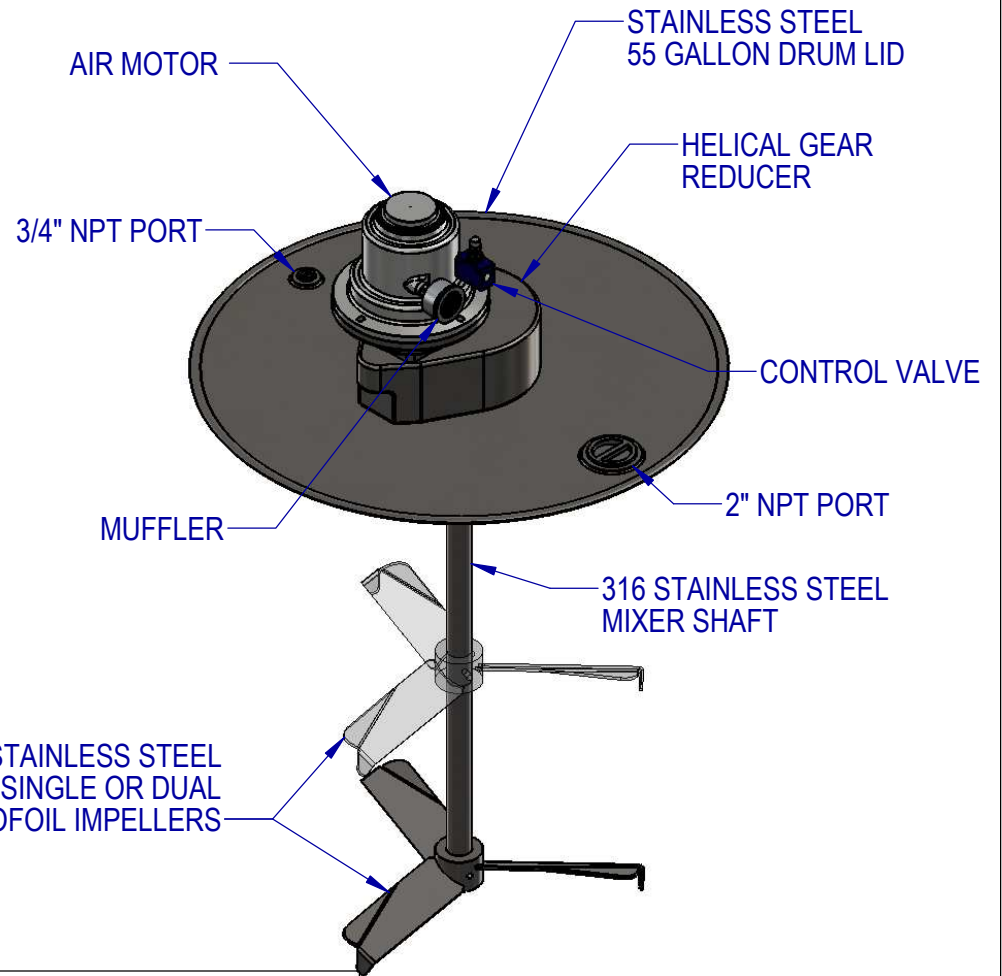
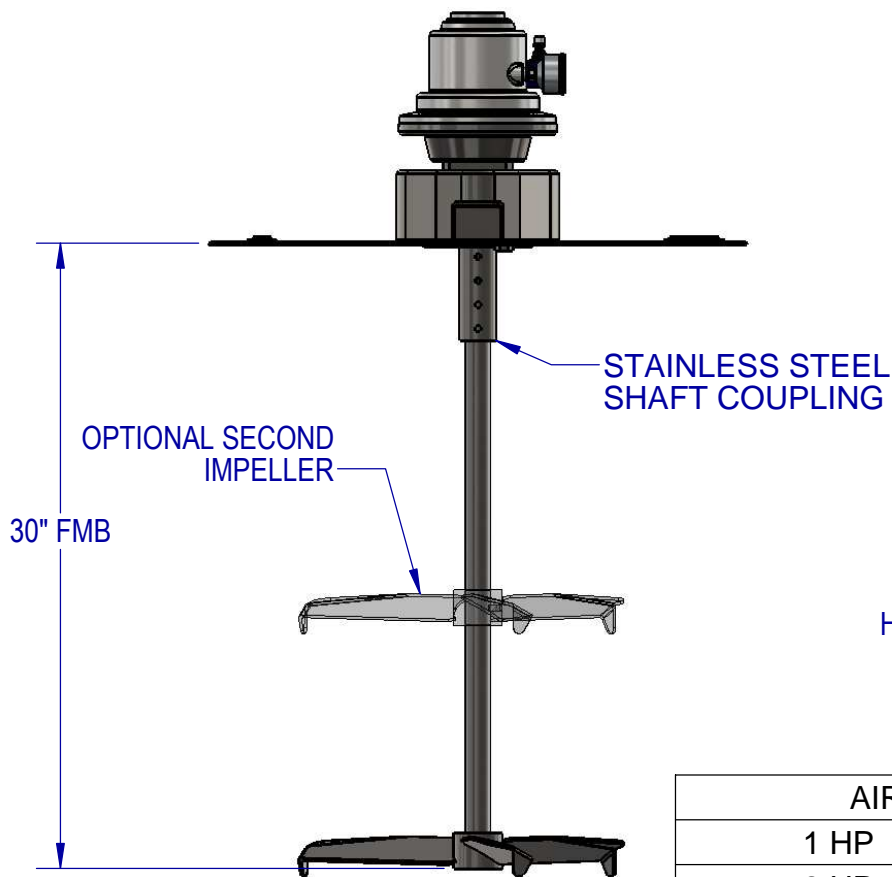

30" FMB

EST WT: 63-82 LBS (DEPENDING ON HP AND OPTIONS)

AIR CONSUMPTION	
1 HP	40 CFM @ 80 PSI
2 HP	60 CFM @ 70 PSI
3 HP	90 CFM @ 100 PSI

NAME	DATE
DRAWN JDF	6/11/13
CHECKED PIC	6/11/13

**PROPRIETARY AND CONFIDENTIAL**  
 THE INFORMATION CONTAINED IN THIS DRAWING IS THE SOLE PROPERTY OF FUSION FLUID EQUIPMENT LLC. ANY REPRODUCTION IN PART OR AS A WHOLE WITHOUT THE WRITTEN PERMISSION OF FUSION FLUID EQUIPMENT LLC IS PROHIBITED.  
 WHILE FUSION FLUID EQUIPMENT LLC STRIVES TO MAINTAIN THE INTEGRITY OF A DESIGN AS APPROVED, FUSION FLUID EQUIPMENT LLC RETAINS THE RIGHT TO MAKE MODIFICATIONS DURING THE MANUFACTURING PROCESS TO IMPROVE FIT, FORM, AND FUNCTION OF THE DESIGN WITHOUT CUSTOMER NOTIFICATION OR CONSENT.



TITLE: DRUM LID MIXER GEAR DRIVE WITH AIR MOTOR		
SIZE <b>A</b>	DWG. NO. SALES-BGA-#D	REV A
SCALE: 1:16	WEIGHT:	SHEET 1 OF 1

UNLESS OTHERWISE SPECIFIED:  
 DIMENSIONS ARE IN INCHES.  
 NO TOLERANCE IS IMPLIED.  
 DO NOT SCALE DRAWING