

STANDARD FEATURES:

- PAINTED THREE PHASE, TEFC, 230/480/60 ELECTRIC MOTOR
- 1750 RPM NOMINAL
- 55 GALLON DRUM LID WITH TWO STANDARD NPT PORTS
- 316SS WETTED PARTS
- 3/4" X 30" FMB SHAFT STANDARD
- SINGLE OR DUAL MARINE IMPELLERS
- WITH SET SCREW ATTACHMENT

OPTIONS:

- SINGLE PHASE TEFC MOTOR
- PREWIRED W/ TOGGLE SWITCH, CORD AND 110V PLUG
- SINGLE SPEED EXPLOSION PROOF MOTOR
- 32 Ra FINISH ON ALL WETTED PARTS

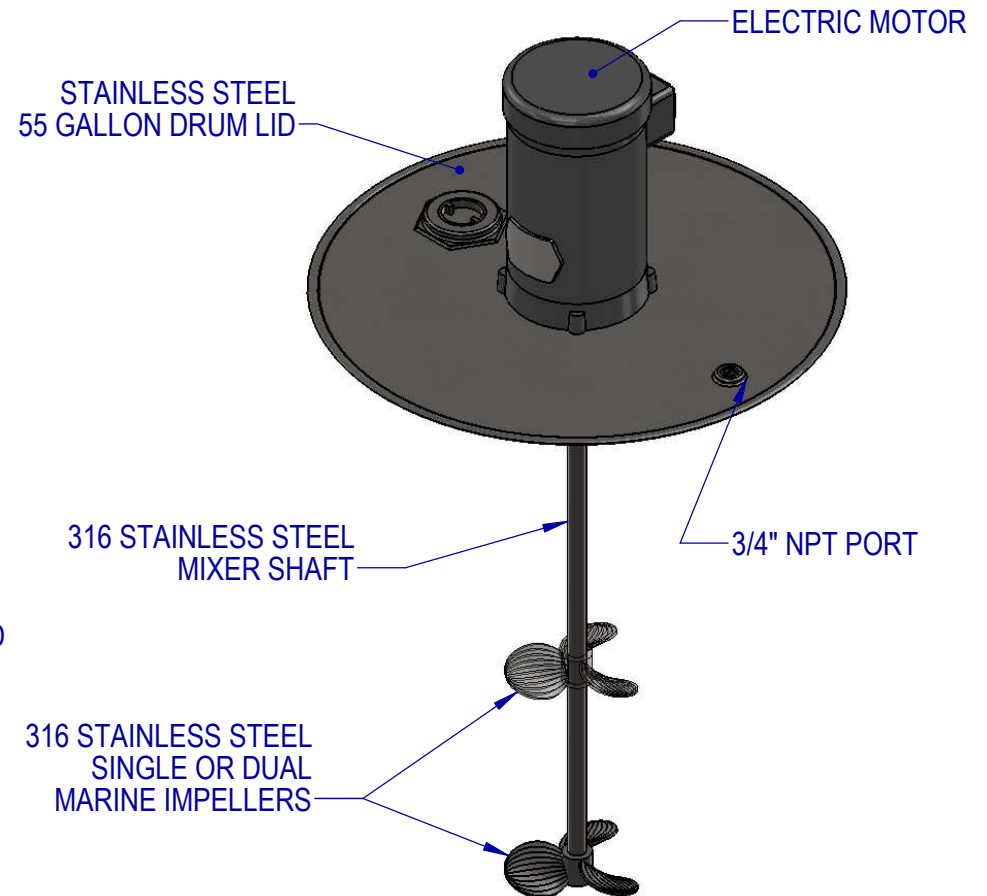
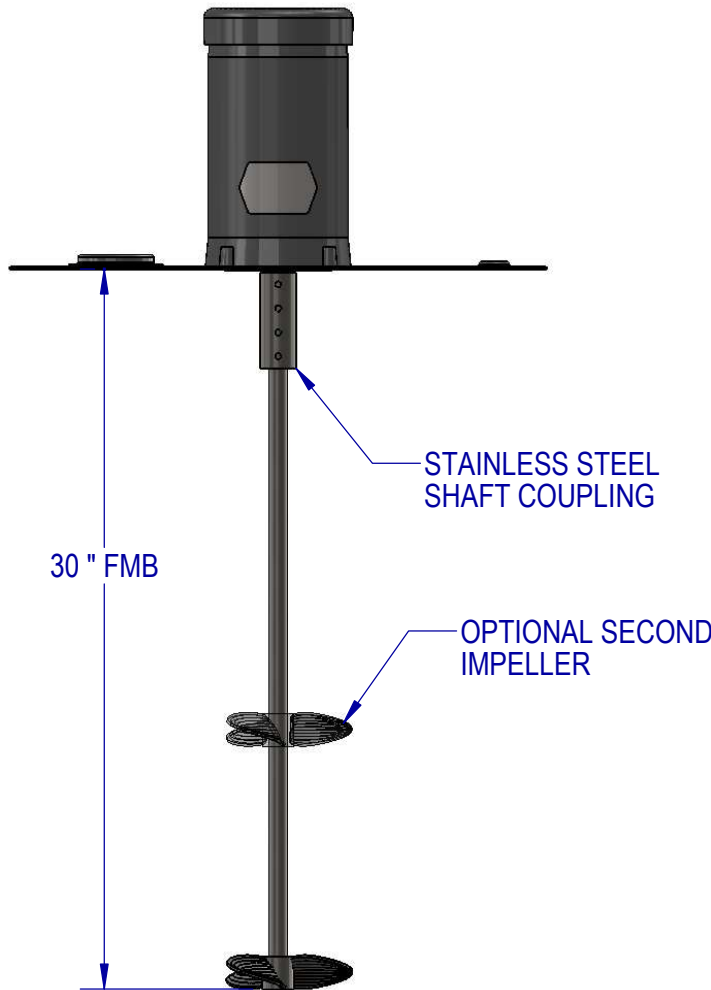

EST WT: 50-73 LBS (DEPENDING ON HP AND OPTIONS)

	NAME	DATE
DRAWN	JDF	6/17/13
CHECKED	TS	6/17/13

PROPRIETARY AND CONFIDENTIAL

THE INFORMATION CONTAINED IN THIS DRAWING IS THE SOLE PROPERTY OF FUSION FLUID EQUIPMENT LLC. ANY REPRODUCTION IN PART OR AS A WHOLE WITHOUT THE WRITTEN PERMISSION OF FUSION FLUID EQUIPMENT LLC IS PROHIBITED.

WHILE FUSION FLUID EQUIPMENT LLC STRIVES TO MAINTAIN THE INTEGRITY OF A DESIGN AS APPROVED, FUSION FLUID EQUIPMENT LLC RETAINS THE RIGHT TO MAKE MODIFICATIONS DURING THE MANUFACTURING PROCESS TO IMPROVE FIT, FORM, AND FUNCTION OF THE DESIGN WITHOUT CUSTOMER NOTIFICATION OR CONSENT.

UNLESS OTHERWISE SPECIFIED:
DIMENSIONS ARE IN INCHES.
NO TOLERANCE IS IMPLIED.
DO NOT SCALE DRAWING



TITLE:
DRUM LID MIXER BUNG MOUNT
DIRECT DRIVE WITH ELECTRIC MOTOR

SIZE	DWG. NO.	REV
A	SALES-BD-#D-#	A
SCALE: 1:48	WEIGHT:	SHEET 1 OF 1