

STANDARD FEATURES:

- PAINTED AIR MOTOR WITH MUFFLER
- 316 STAINLESS STEEL WETTED PARTS
- 3/4" X 30" FMB SHAFT
- SINGLE OR DUAL FOLDING IMPELLERS WITH SET SCREW ATTACHMENT
- SPEED CONTROL VALVE

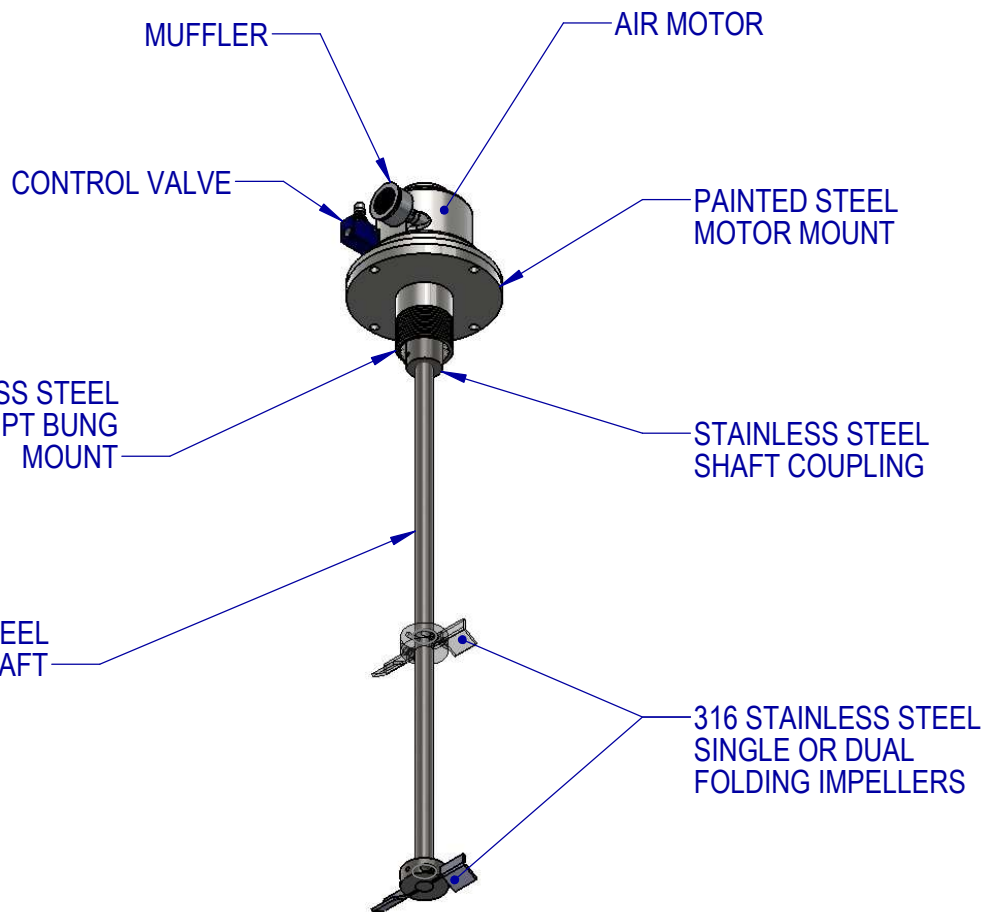
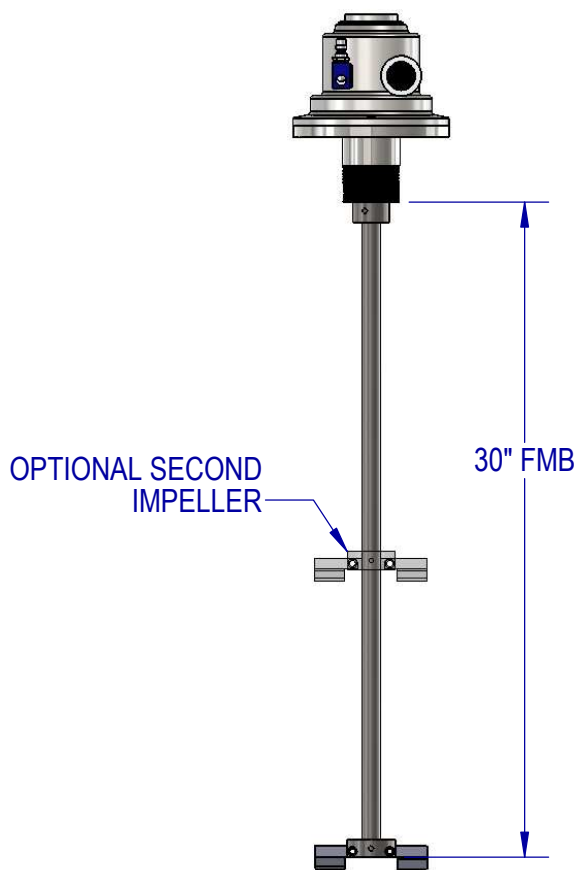

AIR CONSUMPTION	
1 HP	40 CFM @ 80 PSI
2 HP	60 CFM @ 70 PSI
3 HP	90 CFM @ 100 PSI

OPTIONS:

- FILTER, LUBRICATOR, AND REGULATOR (FLR)
- 32 Ra ON ALL WETTED PARTS

EST WT: 27-46 LBS (DEPENDING ON HP AND OPTIONS)

	NAME	DATE
DRAWN	JDF	6/19/13
CHECKED	PIC	6/19/13



PROPRIETARY AND CONFIDENTIAL
 THE INFORMATION CONTAINED IN THIS DRAWING IS THE SOLE PROPERTY OF FUSION FLUID EQUIPMENT LLC. ANY REPRODUCTION IN PART OR AS A WHOLE WITHOUT THE WRITTEN PERMISSION OF FUSION FLUID EQUIPMENT LLC IS PROHIBITED.

TITLE:
**BUNG MOUNT DRUM MIXER
 DIRECT DRIVE AIR MOTOR**

UNLESS OTHERWISE SPECIFIED:
 DIMENSIONS ARE IN INCHES.
 NO TOLERANCE IS IMPLIED.
 DO NOT SCALE DRAWING

WHILE FUSION FLUID EQUIPMENT LLC STRIVES TO MAINTAIN THE INTEGRITY OF A DESIGN AS APPROVED, FUSION FLUID EQUIPMENT LLC RETAINS THE RIGHT TO MAKE MODIFICATIONS DURING THE MANUFACTURING PROCESS TO IMPROVE FIT, FORM, AND FUNCTION OF THE DESIGN WITHOUT CUSTOMER NOTIFICATION OR CONSENT.

SIZE	DWG. NO.	REV
A	SALES-BDA-#B	A
SCALE: 1:12	WEIGHT:	SHEET 1 OF 1