

STANDARD FEATURES:
 PAINTED THREE PHASE, TEFC, 220/440/60 ELECTRIC MOTOR
 1750 RPM NOMINAL
 316SS WETTED PARTS
 3/4" X 30" FMB SHAFT
 SINGLE OR DUAL FOLDING IMPELLERS
 WITH SET SCREW ATTACHMENT

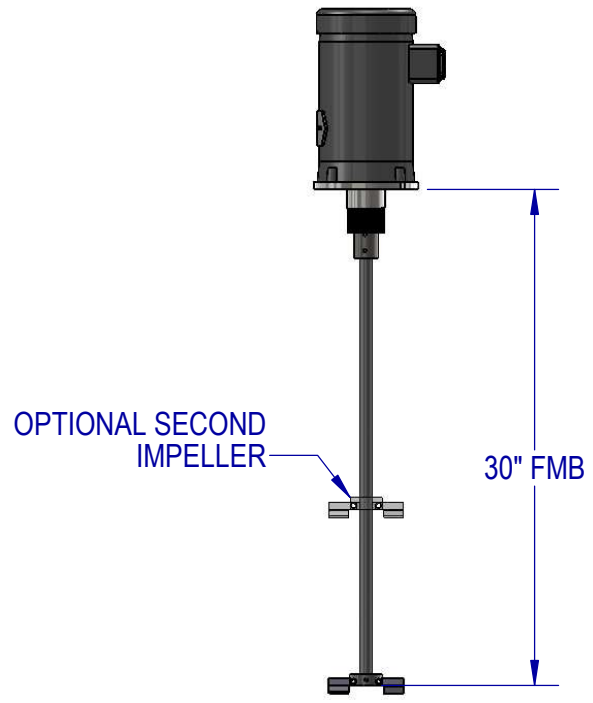

OPTIONS:
 SINGLE PHASE TEFC MOTOR
 PREWIRED W/ TOGGLE SWITCH, CORD AND 110V PLUG
 SINGLE SPEED EXPLOSION PROOF MOTOR
 32 Ra FINISH ON ALL WETTED PARTS

EST WT: 40-63 LBS (DEPENDING ON HP AND OPTIONS)

	NAME	DATE
DRAWN	JDF	6/10/13
CHECKED	PIC	6/10/13



PROPRIETARY AND CONFIDENTIAL
 THE INFORMATION CONTAINED IN THIS DRAWING IS THE SOLE PROPERTY OF FUSION FLUID EQUIPMENT LLC. ANY REPRODUCTION IN PART OR AS A WHOLE WITHOUT THE WRITTEN PERMISSION OF FUSION FLUID EQUIPMENT LLC IS PROHIBITED.
 WHILE FUSION FLUID EQUIPMENT LLC STRIVES TO MAINTAIN THE INTEGRITY OF A DESIGN AS APPROVED, FUSION FLUID EQUIPMENT LLC RETAINS THE RIGHT TO MAKE MODIFICATIONS DURING THE MANUFACTURING PROCESS TO IMPROVE FIT, FORM, AND FUNCTION OF THE DESIGN WITHOUT CUSTOMER NOTIFICATION OR CONSENT.

UNLESS OTHERWISE SPECIFIED:
 DIMENSIONS ARE IN INCHES.
 NO TOLERANCE IS IMPLIED.
 DO NOT SCALE DRAWING

TITLE: BUNG MOUNT DRUM MIXER DIRECT DRIVE ELECTRIC		
SIZE A	DWG. NO. SALES-BD-#B-#	REV A
SCALE: 1:12	WEIGHT:	SHEET 1 OF 1