



**Griffco Valve Inc.**  
188 Creekside Drive  
Amherst, NY 14228  
Phone: 1 716 835-0891  
Fax: 1 716 835-0893

---

# HP-Series Instruction Manual

## High Pressure Relief Valves

---

Call: 1 - 800 - GRIFFCO

Website: [www.griffcovalve.com](http://www.griffcovalve.com)

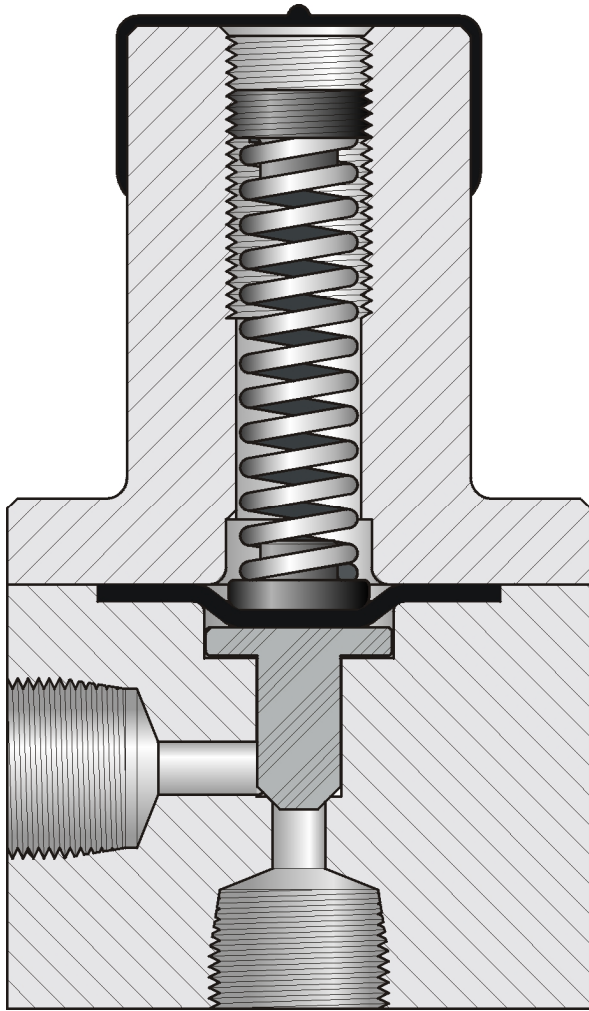

## INTRODUCTION

**Griffco** piston / diaphragm pressure relief valves are designed to protect chemical feed systems from over pressure damage caused by defective equipment or a blockage in the chemical feed line. Robust construction ensures reliability in the rigorous service of municipal and industrial applications. Wetted materials include **316 SS, A 20 and Hast. C**. Available sizes: 1/4", 3/8", 1/2", 3/4" and 1"

## OPERATION:

**Griffco** high pressure relief valves operate when the pressure in the chemical system exceeds the preset pressure of the valve. The piston is held against the valve seat by an internal spring. When the preset pressure is exceeded the piston is forced up and the chemical flows out the relief port, to drain or back to the chemical tank. The valves are pre-set on request, however they are field adjustable from 350 - 2000 psi via the adjustment screw. The relief valve should be set approximately 10% higher than the system operating pressure.

## TYPICAL INSTALLATION HP RELIEF VALVE

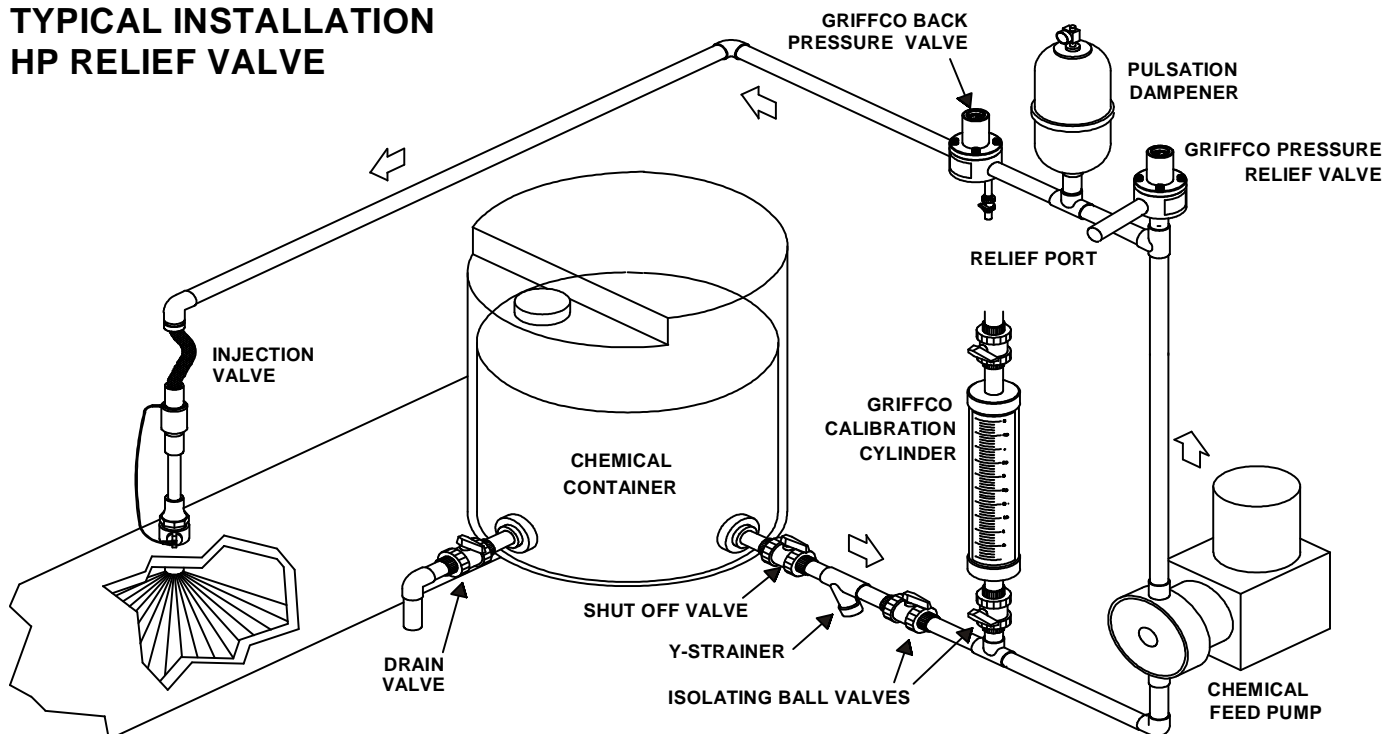

## INSTALLATION:

### Pressure Relief Valve:

Installation should be made as close to the chemical pump discharge valve as possible, without any equipment, especially shut-off valves, between the valve and the pump. Direction of flow must be in the bottom of the valve and relieve out the side. All valves are factory set at 350 psi, unless requested otherwise by the customer. Field adjustment is possible with the adjustment screw. Turn clockwise to increase pressure.

The optimum installation for the relief valve is to vent the relief port back to the chemical tank, or directly to a containment area. However if this is not possible, the relief port can be piped back into the suction side of the pump. This will apply the suction pressure to the relief port. To compensate, divide the suction pressure by 4 and add this pressure to the relief valve setting. Always test the relief valve under normal system operating conditions to ensure it is set properly.

## MAINTENANCE:

The pressure relief valves require a minimal amount of maintenance to keep the valves in operation. Periodic replacement of the diaphragm and piston are required. To facilitate inspection and replacement, the valve layout is such that removal of the diaphragm and piston can be done without taking the valve out of the chemical line.

**Caution: Ensure the system is not under pressure and that the chemical lines are flushed with water before disassembly.**

Unscrew the pressure adjustment screw to remove the pressure from the valve. Remove the 4 bolts and lift off the valve top.

After the diaphragm, piston and the valve seat have been inspected and replaced if necessary check the adjustment spring. Make sure there is no rust or corrosion. Replace the spring and the support disc into the valve top, slide the top back over the valve body and align the bolt holes.

Snug down the four bolts. Screw in the adjustment screw to approximately the same position as it was prior to disassembly. If an exact pressure setting is required or a different pressure is desired a pressure gauge should be used to verify the setting. Pressure can be increased by turning the pressure adjustment screw clockwise.

## DIMENSIONS:

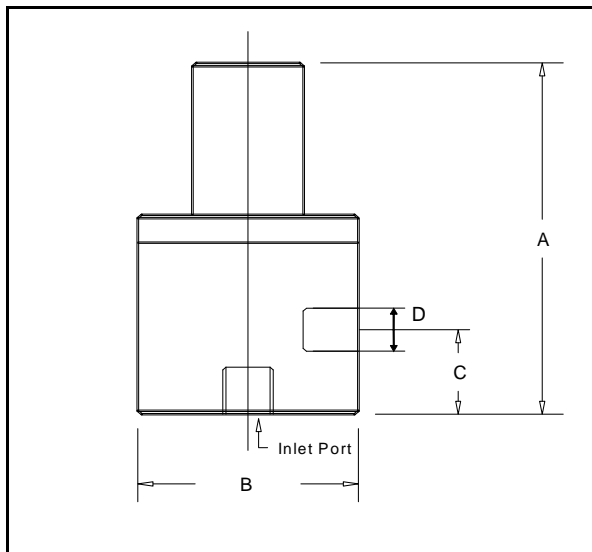

D	A	B	C
1/4"	4.23	2.375	1.125
3/8"	4.23	2.375	1.125
1/2"	4.23	2.375	1.125
3/4"	5.89	3.50	1.375
1"	5.89	3.50	1.375

**NOTE: Dimensions are general. See dimension sheets for exact sizes of various material valves.**

# PARTS LIST

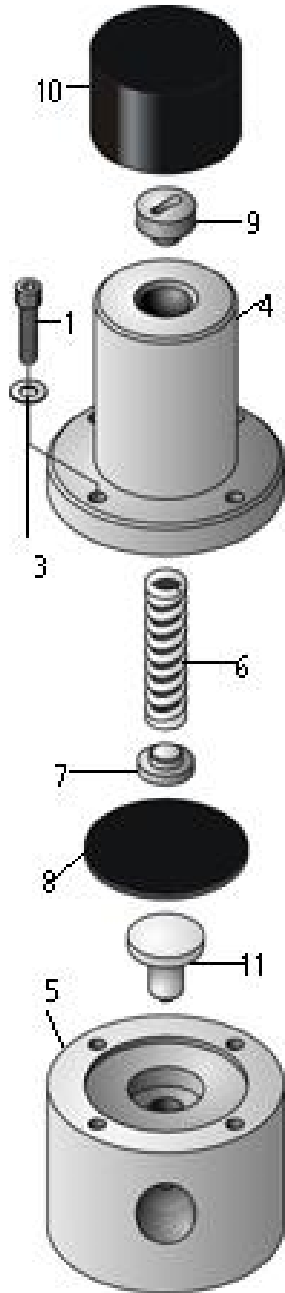

ITEM	DESCRIPTION	PART #
1	Bolt - 1/4" Metal Valves – 10/32 X 3/4" Bolt - 1/2 - 1" Metal Valves – 1/4 - 20 x 1 1/4"	PV-00107 PV-00108
2	N/A	N/A
3	10/32 Flat washer 1/4 Flat washer	PV-00301 PV-00302
4	1/4" – 1/2" HP Valve Top – 316 SS 3/4" - 1" HP Valve Top - 316 SS	PV-00403HP PV-00407HP
5	1/4" Valve Body High Pressure - 316 SS 1/4" Valve Body High Pressure - Alloy 20 1/4" Valve Body High Pressure - Hast C 3/8" Valve Body High Pressure - 316 SS 3/8" Valve Body High Pressure - Alloy 20 3/8" Valve Body High Pressure - Hast C 1/2" Valve Body High Pressure - 316 SS 1/2" Valve Body High Pressure - Alloy 20 1/2" Valve Body High Pressure - Hast C 3/4" Valve Body High Pressure - 316 SS 3/4" Valve Body High Pressure - Alloy 20 3/4" Valve Body High Pressure - Hast C 1" Valve Body High Pressure - 316 SS 1" Valve Body High Pressure - Alloy 20 1" Valve Body High Pressure - Hast C	PRV-00505HP PRV-00506HP PRV-00507HP PRV-00565HP PRV-00566HP PRV-00567HP PRV-005151HP PRV-005161HP PRV-005171HP PRV-00525HP PRV-00526HP PRV-00527HP PRV-00535HP PRV-00536HP PRV-00537HP
6	Pressure Spring - 1/4" – 1/2" Valve Pressure Spring - 3/4" – 1" Valve	PV-006012 PV-006122
7	Support Disc - 1/4 - 1/2" Valve, 316 SS Support Disc - 3/4" - 1" Valve, 316 SS	PV-00702 PV-00706
8	Diaphragm - 1/4" – 1/2" Valve – PTFE/EPDM Diaphragm - 1/4" – 1/2" Valve – Viton Diaphragm – 3/4" – 1" Valve – PTFE/EPDM Diaphragm – 3/4" – 1" Valve – Viton	PV-00800 PV-00802 PV-00810 PV-00812
9	Adjustment Screw - 1/4" - 1" Valve Coated Steel	PV-00903
10	Plastic Cap – 1/4" – 1/2" Plastic Cap – 3/4" – 1"	PV-01001 PV-01002
11	1/4" – 1" HP Piston - PVDF	PHP00851

**Warranty:** GRIFFCO Valve, Inc. warrants its products against defects in workmanship and materials for one year under normal use or 18 months from date of shipment whichever occurs first. All obligations and liabilities under this warranty are limited to repair or replacement (at our option), FOB our plant such allegedly defective units as are returned to our factory transport prepaid. Repairs or replacements are made subject to inspection of returned items. This warranty does not extend to damage by corrosion or erosion. The materials of construction offered are recommendations subject in all cases to acceptance by the customer. These recommendations, based on previous experience and best available information, do not constitute guarantees against wear or chemical action. Expressly excluded from this warranty are defects caused by misuse, abuse or improper application, installation or operation of the unit. No liability for consequential damages or reinstallation labor is accepted. GRIFFCO Valve, Inc. will not assume responsibility for contingent liability for alleged failure of its produce