

FLOWLINE

EchoSwitch®

Ultrasonic Level Switch and Transmitter

LU77 Series Quick Start



QS300284 Rev A
©2013 Flowline, Inc.
All Rights Reserved
Made in USA

10500 Humbolt Street, Los Alamitos, CA 90720 USA
Tel: 562.598.3015 • Fax: 562.431.8507 • www.flowline.com



Welcome to the EchoSwitch® Quick Start

The EchoSwitch® Quick Start provides basic mounting, setup and use instructions for getting the EchoSwitch® up and running quickly. If you have a non-standard installation or setup requirement that is not addressed here, please refer to the EchoSwitch® Manual or other support documentation located at www.flowline.com.

We Do Your Level Best

Thank you for purchasing EchoSwitch®. The sensor provides integrated LCD and three push-button configuration. This quick start includes everything you'll need to get the sensor up and running.

Components

Depending on how the sensor model that was shipped, EchoSwitch® comes with a Viton® gasket for installation and the Quick Start.

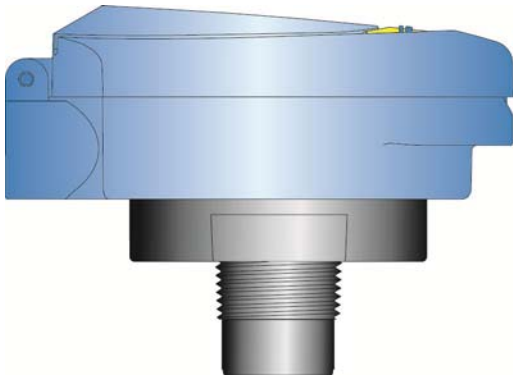

EchoSwitch®
LU77 Series

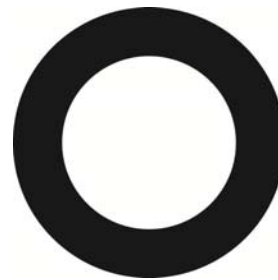

Viton® gasket (1")
P/N: 200128

Mounting the EchoSwitch®

The sensor should always be mounted perpendicular to the liquid surface using the provided Viton® mounting gasket. Make sure that there are no restrictions or obstacles in the path of the acoustic signal. For further mounting information, please refer to the EchoPod® manual and instruction video located at www.flowline.com.

EchoSwitch® has 1" NPT or G threads and requires care in fitting selection and mounting to reduce any coupling of the ultrasonic signal to the mounting structure. The below fittings are recommended.

Installation in existing 2" fittings:

- 1) Use a LM52-1400 2" thread x 1" thread adapter or a LM52-1410 2" slip x 1" thread adapter. Adapters with an air gap around the 1 inch threads are recommended.

Installation in plastic tanks (use one of the following):

- 1) Use a 1" bulkhead fitting, such as the LM52-1890 bulkhead fitting.
- 2) Use a larger bulkhead fitting, such as the LM52-2890 with a reducer bushing such as the LM52-1400.
- 3) Weld a plastic 1" half coupling to the tank top.

Installation in metal tanks (use one of the following):

- 1) Use the LM52-1890 bulkhead fittings.
- 2) Use a flange with a 1" riser, such as the LM52-1850 (where the thread is above the plane of the flange). **Do not use a blind flange with a tapped 1" thread.**
- 3) Use a larger flange with a 2" thread and add a reducer bushing such as the LM52-1400.

Note: While installations directly into a 1" metal fitting are not recommended, acceptable results may be obtained if the 1" fitting is a half coupling in form and the outer diameter of the coupler is tightly wrapped with vinyl tape.

Installation in open tanks and sumps:

- 1) Use Flowline's LM50-1001-1 side mount bracket.



LM52-1400



LM52-1410



LM52-2890



LM52-1850



LM50-1001

IMPORTANT MOUNTING GUIDELINES:

- 1) Never mount the sensor at an angle.
- 2) Liquid should never enter the dead band.
- 3) Mount at least 3" from the side wall.
- 4) Never mount in a vacuum.
- 5) Do not obstruct the sensor's beam width.

Mounting with a Stand-Pipe:

A stand-pipe may be used to dampen turbulence, separate surface foam from the point of measurement or increase performance in heavy vapor. When mounting the sensor in a stand-pipe, the minimum diameter of the pipe is 2". Larger diameter pipes can be used. The pipe should be attached with a coupling or tank adapter and reducer bushing. Avoid the use of multiple pipe fittings when possible. An ideal mount would be to select a 2" coupling (S x T or S x S) and connect the pipe to the inside slip and use a reducer bushing to attach the sensor (see example below).

The pipe length should run the measurement span and the bottom of the pipe should remain submerged at all times to prevent foam from entering the pipe. Cut the bottom end of the pipe at 45° and drill a 1/4" pressure equalization hole high in the dead band. The pumps should not drive liquid past the open end of the standpipe which causes the liquid in the pipe to oscillate.

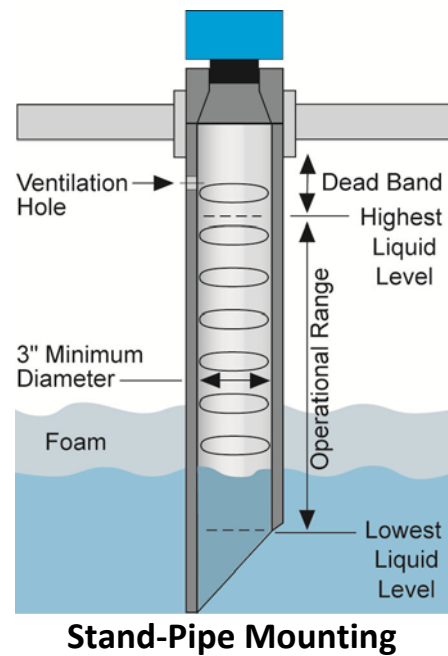
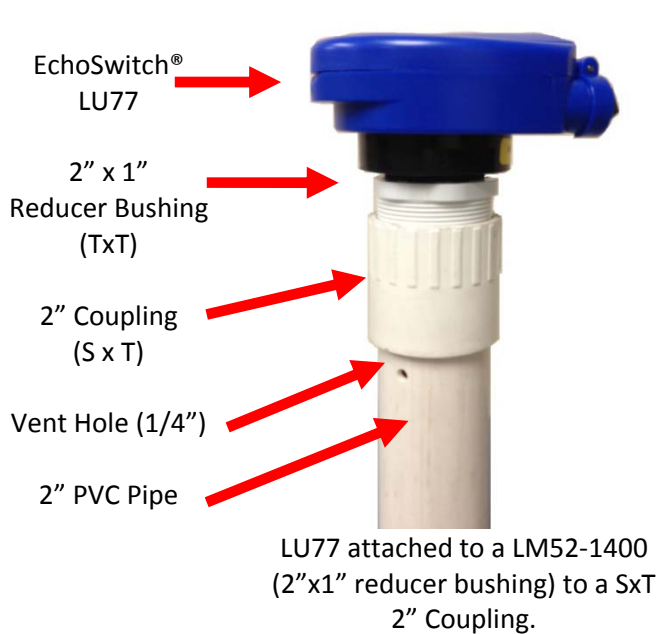

Wiring the EchoSwitch®

The following wiring diagram can be used when wiring to the EchoSwitch® relays.

Note: All three relays share the COM terminal. Relay 1 has both a NO and NC terminal while Relays 2 and 3 have just a NO terminal.

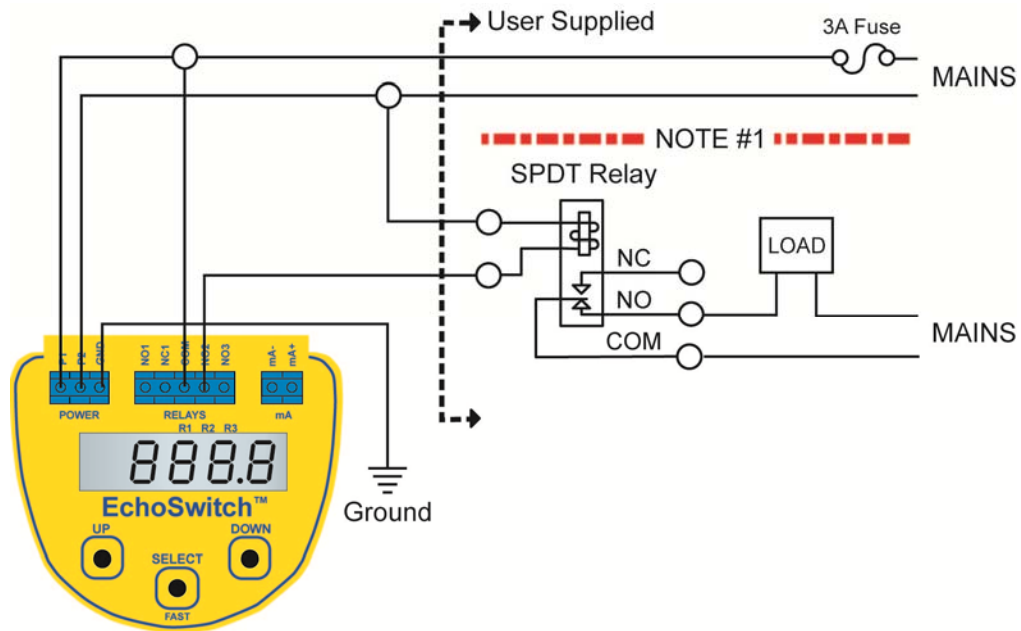

- **Note #1** – Isolate power to instrument from power to load (pumps, etc.) as much as possible by running power to the sensor directly from main power source.

The following wiring diagrams can be used for the 4-20 mA output of the EchoSwitch®.

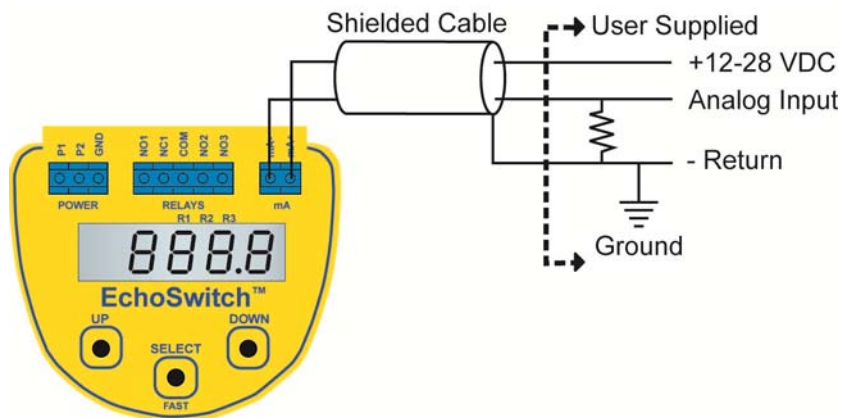

Some notes on safety:

- Where personal safety or significant property damage can occur due to a spill, the installation must have a redundant backup safety system installed.
- Wiring should always be completed by a licensed electrician.
- The sensor must be chemically compatible with the application.
- Design a fail-safe system for possible sensor and/or power failure.
- Never use the sensor in classified hazardous environments.

Configuring the Sensor

EchoSwitch® can be configured before installation. The switch features non-volatile memory, so the set points configured before installation will not be lost when the switch is powered down. To start, all you need is the following information:

- Basic Tank Information
 - HEIGHT – Distance from the transducer face to the bottom of the tank.
 - FILL-H – Maximum fill height of the liquid from the bottom of the tank.
- Set Points (Relays):
 - You will need the measured distance from the bottom of the tank to each set point.
 - Pump and Valve operations will have two set points, one for ON and the other for OFF.
 - These values will all be in the same unit of measurement (inches, centimeters, feet or meters) and will all be measured from the bottom of the tank.
- Power:
 - Provide input power to the EchoSwitch®.

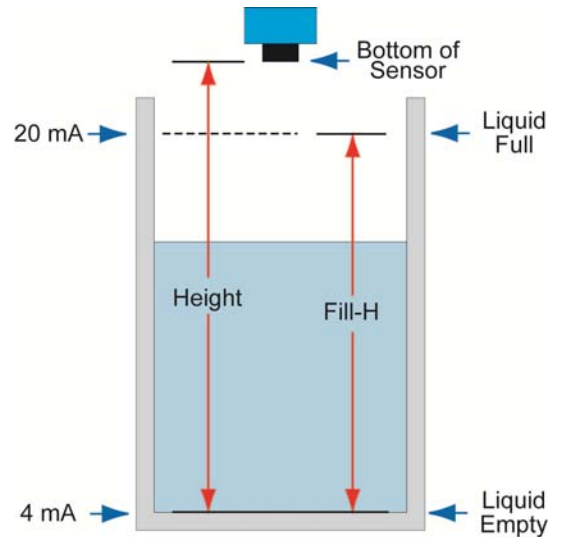

Note: The Height and Fill Height settings also determine the 4 to 20 mA current span. The Height setting determines the 4mA position and the Fill-H setting determines the 20 mA position.

TOP-LEVEL MENU

The sensor is configured with the three buttons on the sensor face (**UP**, **DOWN** and **SELECT**) and the sensor's LCD. To access the sensor's Top-level menu, simply hold down the SELECT button for five seconds. The display menu will automatically begin to scroll through the TOP-LEVEL MENU.

When the menu scrolls to an item you wish to configure, simply press the SELECT button to choose that item. The TOP-LEVEL MENU will continue to scroll through the following (**UNITS – TANK – RELAY 1 – RELAY 2 – RELAY 3 – SAFE – (MPLEX) - HELP – RUN**), so if you miss your selection, it will appear again shortly.



- To return to the TOP-LEVEL MENU, press SELECT when **EXIT** appears.
- To return to Operational Mode of the sensor, press SELECT when **RUN** appears in the TOP-LEVEL MENU.
- **Note:** To speed up the scrolling of the values on the display, hold down the SELECT button while holding down the UP or DOWN buttons.

Set Units

The EchoSwitch® displays information in the following units: inches, feet, centimeters, meters or percentage. The value shown on the display represents the amount of liquid in the tank.

- 1) Press & hold SELECT for 5 seconds to enter TOP-LEVEL MENU.
- 2) Select **UNITS**.
- 3) Select the type of units by pressing SELECT.
- 4) Select **EXIT** to return to the TOP-LEVEL MENU.
- 5) Select **RUN** to return to Operational Mode.

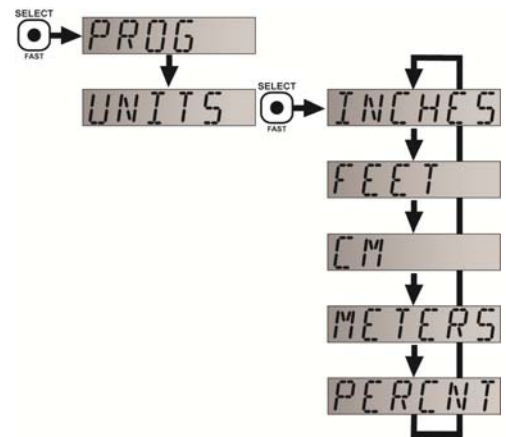

Set Height and Fill Height

This setting customizes the reading for your installation. Follow these instructions to set the height and fill height for your tank:

- 1) Press & hold SELECT for 5 seconds to enter TOP-LEVEL MENU.
- 2) Select **TANK**.
- 3) Select **HEIGHT**.
- 4) Use the UP and DOWN buttons to set the height of your tank. To enter value, press and hold SELECT for 2 seconds and release. **SAVED** will display.

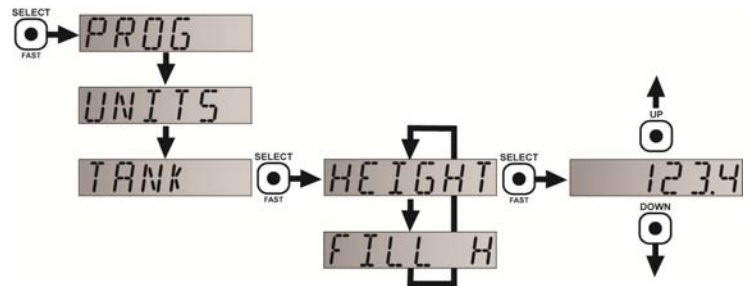

- 5) Select **FILL-H**.
- 6) Use the UP and DOWN buttons to set the fill height of your tank. To enter value, press and hold SELECT for 2 seconds and release. **SAVED** will display.
- 7) Select **EXIT** to return to the TOP-LEVEL MENU.
- 8) Select **RUN** to return to Operational Mode.

Note: The Height and Fill Height settings also determine the 4 to 20 mA current span. The Height setting determines the 4mA position and the Fill-H setting determines the 20 mA position.

Set a High Alarm Relay

A high alarm relay will notify you when the tank level reaches a preset high level:

- 1) Press and hold SELECT for 5 seconds to enter TOP-LEVEL MENU.
- 2) Select **RELAY1, RELAY2 or RELAY3.**
- 3) Select **ALARM.**
- 4) Select **HIGH (SAVED appears).**
- 5) Use the UP and DOWN buttons to set the **HIGH (ON)** set point for the relay. To enter value, press and hold SELECT for 2 seconds and release. **SAVED** will display.
- 6) Select **HYSTER** (Hysteresis).
- 7) Use the UP and DOWN buttons to set the **HYSTER (OFF)** set point. To enter value, press and hold SELECT for 2 seconds and release. **SAVED** will display.
- 8) Select **EXIT** to return to the TOP-LEVEL MENU.

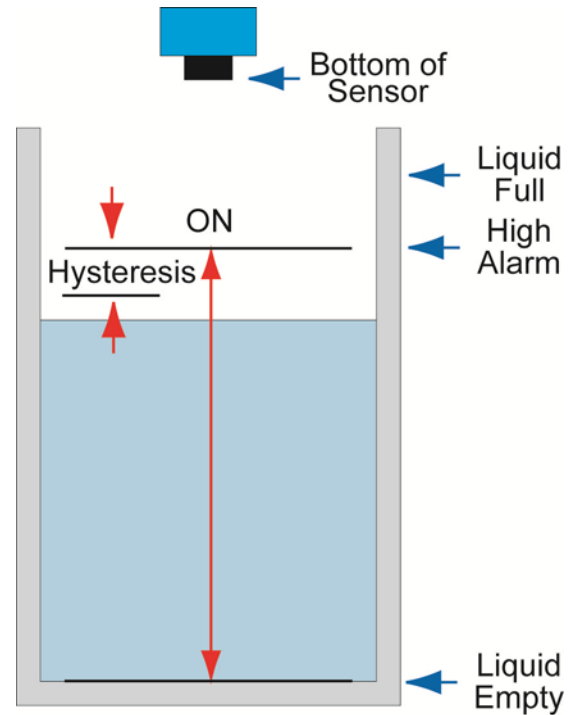

Set a Low Alarm Relay

A low alarm relay will notify you when the tank level reaches a preset low level:

- 1) Press and hold SELECT for 5 seconds to enter TOP-LEVEL MENU.
- 2) Select **RELAY1, RELAY2 or RELAY3.**
- 3) Select **ALARM.**
- 4) Select **LOW (SAVED appears).**
- 5) Use the UP and DOWN buttons to set the **LOW (ON)** set point for the relay. To enter value, press and hold SELECT for 2 seconds and release. **SAVED** will display.
- 6) Select **HYSTER** (hysteresis).
- 7) Use the UP and DOWN buttons to set the **HYSTER (OFF)** set point. To enter value, press and hold SELECT for 2 seconds and release. **SAVED** will display.
- 8) Select **EXIT** to return to the TOP-LEVEL MENU.

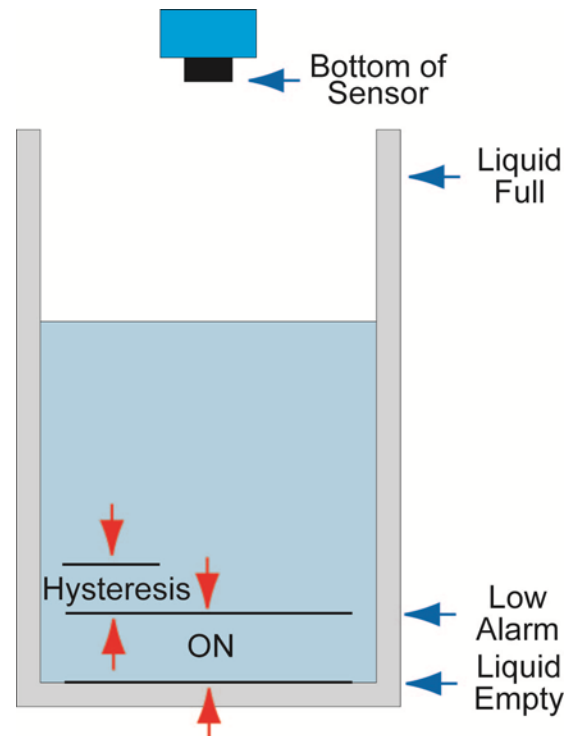

Fill a Tank with a Pump or Valve

The relays can also be used to automatically fill a tank when the level inside drops too low. To set the sensor to automatically fill a tank:

- 1) Press and hold **SELECT** for 5 seconds to enter **TOP-LEVEL MENU**.
 - 2) Select **RELAY1, RELAY2 or RELAY3**.
 - 3) Select **PUMP or VALVE (SAVED appears)**.
 - 4) Select **FILL (SAVED appears)**.
 - 5) Select **ON**.
 - 6) Use the **UP** and **DOWN** buttons to set the **ON** set point for the relay. This is the lower of the two set points. To enter value, press and hold **SELECT** for 2 seconds and release. **SAVED** will display.
 - 7) Select **OFF**.
 - 8) Use the **UP** and **DOWN** buttons to set the **OFF** set point for the relay. This is the higher of the two set points. To enter value, press and hold **SELECT** for 2 seconds and release. **SAVED** will display.
- If you wish to add a delay when the pump starts, continue to step 9. Otherwise, select **EXIT** to return to the top-level menu.
- 9) Select **DELAY**.
 - 10) Using the **UP** and **DOWN** buttons, set the **DELAY** time in seconds. This pump delay can range from 0 to 600 seconds. To enter value, press and hold **SELECT** for 2 seconds and release. **SAVED** will display.
 - 11) Select **EXIT** to return to the **TOP-LEVEL MENU**.

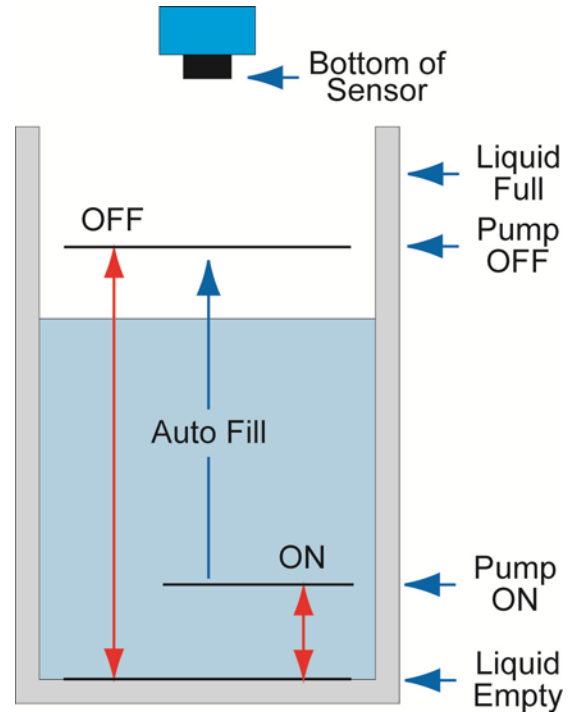

Empty a Tank with a Pump or Valve

The relays can also be used to automatically empty a tank when the level inside gets too high. To set the sensor to automatically empty a tank:

- 1) Press and hold **SELECT** for 5 seconds to enter **TOP-LEVEL MENU**.
- 2) Select **RELAY1, RELAY2 or RELAY3**.
- 3) Select **PUMP or VALVE (SAVED appears)**.
- 4) Select **EMPTY (SAVED appears)**.
- 5) Select **ON**.
- 6) Use the **UP** and **DOWN** buttons to set the **ON** set point for the relay. This is the higher of the two set points. To enter value, press and hold **SELECT** for 2 seconds and release. **SAVED** will display.
- 7) Select **OFF**.
- 8) Use the **UP** and **DOWN** buttons to set the **OFF** set point for the relay. This is the lower of the two set points. To enter value, press and hold **SELECT** for 2 seconds and release. **SAVED** will display.
- 9) Select **DELAY**.
- 10) Using the **UP** and **DOWN** buttons, set the **DELAY** time in seconds. This pump delay can range from 0 to 600 seconds. To enter value, press and hold **SELECT** for 2 seconds and release. **SAVED** will display.
- 11) Select **EXIT** to return to the **TOP-LEVEL MENU**.

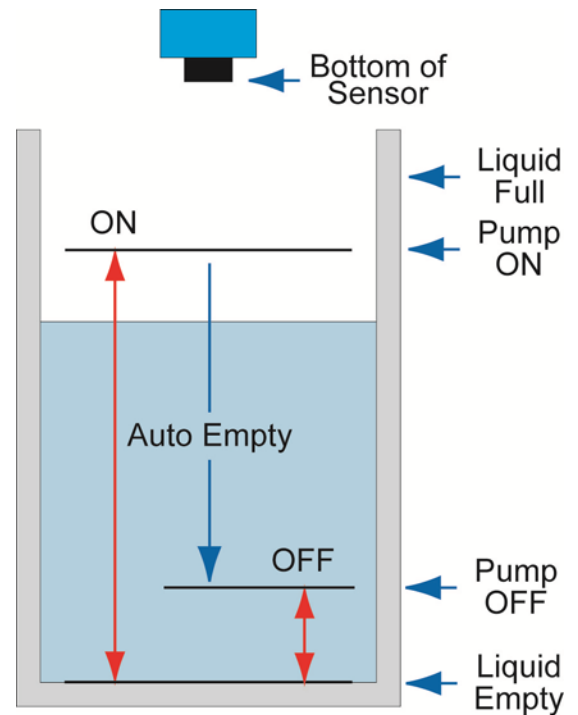

Select Relay Fail Safety Output / LOST

In the event the sensor does not receive an echo, the Fail Safety Output or **LOST** setting can be set to turn each relay **ON**, **OFF** or **HOLD** (to last state) to achieve the desired fail-safe condition. During fail-safe, the display will read **LOST**.

- 1) Press and hold **SELECT** for 5 seconds to enter TOP-LEVEL MENU.
- 2) Select **SAFE**.
- 3) Select **R1** (relay 1), **R2** (relay 2) or **R3** (relay 3).
- 4) Select an output option, such as **ON**, **OFF**, or **HOLD**. To enter value, press and hold **SELECT** for 2 seconds and release. **SAVED** will display.
- 5) Select **EXIT** to return to the TOP-LEVEL MENU.

Power Outage

If power to the EchoSwitch® is removed (intentionally or accidentally), the relays will return to the normal state. Thus, in Relay 1, NC terminal will be closed and NO terminal will be open. Also, the NO terminals in relays 2 and 3 will also be open. Make sure that the de-energized state is the safe state in your system design. The EchoSwitch® does use non-volatile memory so any power loss will not affect the settings or configuration of the sensor.

Select Fail-Safe Current Output / LOST: In the event the sensor does not receive an echo, the Fail-Safe Current Output or **LOST** setting can be set to output a current of **4mA**, **21mA** or **HOLD** (last known value). During fail-safe, the display will read **LOST**.

- 1) Press and hold **SELECT** for 5 seconds to enter TOP-LEVEL MENU.
- 2) Select **SAFE**.
- 3) Select **OUTPUT**.
- 4) Select an output option, such as **4mA**, **21mA**, or **HOLD**. To enter value, press and hold **SELECT** for 2 seconds and release. **SAVED** will display.
- 5) Select **EXIT** to return to the TOP-LEVEL MENU.

Troubleshooting

If you face any issues not addressed in this Quick Start, please refer to the EchoSwitch® Manual located on Flowline's website at www.flowline.com.

Information on how to set a LOW or HIGH alarm, as well as how to FILL or EMPTY a tank with a pump, can also be found in the EchoSwitch® Manual located on Flowline's website at www.flowline.com.

Warranty

Flowline warrants to the original purchaser of its products that such products will be free from defects in material and workmanship under normal use and service in accordance with instructions furnished by Flowline for a period of two years from the date of manufacture of such products. Flowline's obligation under this warranty is solely and exclusively limited to the repair or replacement, at Flowline's option, of the products or components, which Flowline's examination determines to its satisfaction to be defective in material or workmanship within the warranty period. Flowline must be notified pursuant to the instructions below of any claim under this warranty within thirty (30) days of any claimed lack of conformity of the product. Any product repaired under this warranty will be warranted only for the remainder of the original warranty period. Any product provided as a replacement under this warranty will be warranted for the full two years from the date of manufacture.

Returns

Products cannot be returned to Flowline without Flowline's prior authorization. To return a product that is thought to be defective, go to www.flowline.com, and submit a customer return (MRA) request form and follow the instructions therein. All warranty and non-warranty product returns to Flowline must be shipped prepaid and insured. Flowline will not be responsible for any products lost or damaged in shipment.

Limitations

This warranty does not apply to products which: 1) are beyond the warranty period or are products for which the original purchaser does not follow the warranty procedures outlined above; 2) have been subjected to electrical, mechanical or chemical damage due to improper, accidental or negligent use; 3) have been modified or altered; 4) anyone other than service personnel authorized by Flowline have attempted to repair; 5) have been involved in accidents or natural disasters; or 6) are damaged during return shipment to Flowline. Flowline reserves the right to unilaterally waive this warranty and dispose of any product returned to Flowline where: 1) there is evidence of a potentially hazardous material present with the product; or 2) the product has remained unclaimed at Flowline for more than 30 days after Flowline has dutifully requested disposition. This warranty contains the sole express warranty made by Flowline in connection with its products. ALL IMPLIED WARRANTIES, INCLUDING WITHOUT LIMITATION, THE WARRANTIES OF MERCHANTABILITY AND FITNESS FOR A PARTICULAR PURPOSE, ARE EXPRESSLY DISCLAIMED. The remedies of repair or replacement as stated above are the exclusive remedies for the breach of this warranty. IN NO EVENT SHALL FLOWLINE BE LIABLE FOR ANY INCIDENTAL OR CONSEQUENTIAL DAMAGES OF ANY KIND INCLUDING PERSONAL OR REAL PROPERTY OR FOR INJURY TO ANY PERSON. THIS WARRANTY CONSTITUTES THE FINAL, COMPLETE AND EXCLUSIVE STATEMENT OF WARRANTY TERMS AND NO PERSON IS AUTHORIZED TO MAKE ANY OTHER WARRANTIES OR REPRESENTATIONS ON BEHALF OF FLOWLINE. This warranty will be interpreted pursuant to the laws of the State of California. If any portion of this warranty is held to be invalid or unenforceable for any reason, such finding will not invalidate any other provision of this warranty.

For complete product documentation, video training, and technical support, go to www.flowline.com.

For phone support, call 562-598-3015 from 8am to 5pm PST, Mon - Fri.

(Please make sure you have the Part and Serial number available.)