

LE-DX0HX, DX8HX

When pumping solutions, make certain that all tubing is securely attached to the fittings. It is recommended that tubing or pipe lines be shielded to prevent possible injury in case of rupture or accidental damage. Always wear protective clothing and face shield when working on or near your metering pump.

Note: See parts list for materials of construction

A. INSTALLING INJECTION CHECK VALVE (FIGURE 1)

1. The Injection Check Valve prevents backflow from a treated line. Install the injection check valve at the location where chemical is being injected into the system.
2. Any size Female NPT fitting or pipe tee with a reducing bushing to 1/2" Female NPT will accept the injection check valve. PTFE tape should only be used on threads that are connected with pipes.
3. When installing the Injection Check Valve, be sure to position it so that the valve enters the bottom of your pipe in a vertical position. Variations 40° left and right are acceptable.

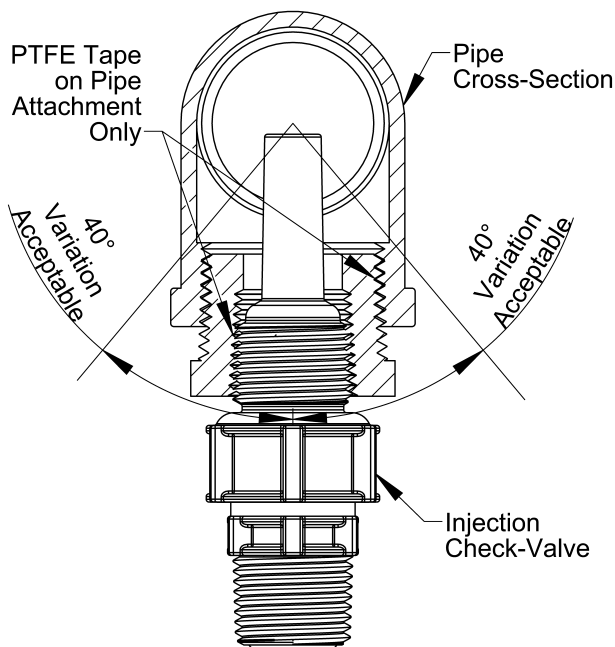

FIGURE 1

B. CONNECTING DISCHARGE TUBING (FIGURE 2)

Please note: The chemical discharges through the ROYTRONIC® 4-function valve which is mounted to the front of the AUTOPRIME™ liquid end, as seen in Figure 3.

Note: Cut tubing to length needed for discharge line.

1. Route tubing from the injection check valve to the metering pump, making sure it does not touch hot or sharp surfaces, or is bent so sharply that it kinks.
2. Put coupling nut over tubing.

3. Position female Ferrule about one inch (25 mm) from end of tubing.
4. For 1/4" or 6 mm OD tubing, cut tubing so that 1/4" to 3/8" (5-10 mm) protrudes from the female Ferrule. For all other tubing push the tube to the bottom of the groove in the male Ferrule. Then slide the female Ferrule down into the male Ferrule.
5. Firmly hand tighten the coupling nut onto the fitting.

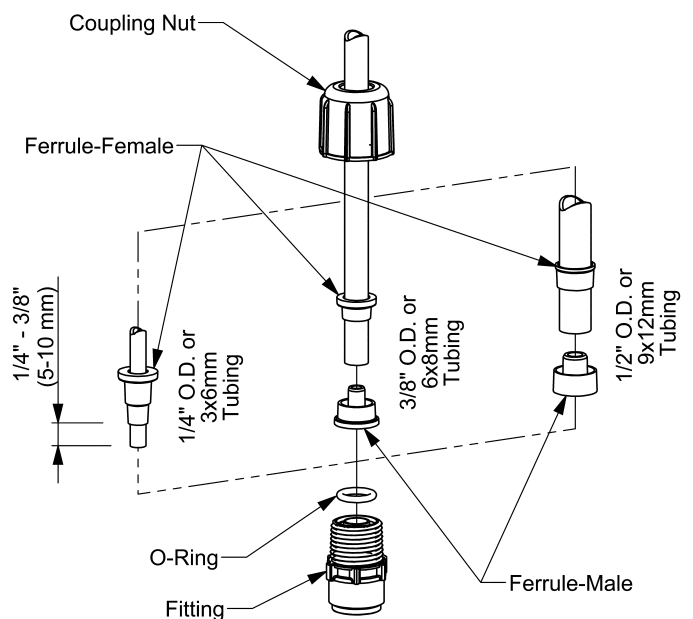

FIGURE 2

DO NOT USE CLEAR VINYL TUBING ON THE DISCHARGE SIDE OF THE PUMP.

DO NOT USE PLIERS OR PIPE WRENCH ON COUPLING NUTS OR FITTINGS.

C. CONNECTING SUCTION TUBING

1. Cut suction tubing to a length so that the foot valve hangs just above the bottom of the solution container. Maximum recommended vertical suction lift is 5 ft (1.5m).
2. Follow same procedure in connecting suction tubing to suction valve and foot valve (see **B. Connecting Discharge Tubing**).



201 Ivyland Road
Ivyland, PA 18974 USA
TEL: (215) 293-0401
FAX: (215) 293-0445
<http://www.lmipumps.com>

D. CONNECTING AUTOPRIME™ TUBING

1. Using 1/2" O.D. polyethylene tubing, cut AUTOPRIME™ tubing to length so that it returns to the solution tank. This tubing must not be submerged in the solution.
2. Follow the same procedure in connecting AUTOPRIME™ tubing to the AUTOPRIME™ valve (see **B. Connecting Discharge Tubing**).

E. PRIMING WITH ROYTRONIC® 4-FUNCTION VALVE

1. Connect pressure relief tubing to the pressure relief port (Figure 3). Route tubing to the solution tank. This tubing must not be submerged in the solution.
- When all precautionary steps have been taken, the pump is mounted, and the tubing is securely attached, you may now start priming the pump.
2. Turn black knob about 1/8 turn CCW to stop point to open bypass port.
 3. Set pump at 100% speed and 100% stroke length. Start pump. When fluid has been flowing through the bypass port tubing for 10-20 seconds, the pump is primed.
 4. Stop pump and return black knob to normal position.

Note: The pumps are normally self priming if suction lift is less than 5 feet (1.5 meters), check valves are wet (there is usually water in the pump head when shipped from the factory), and the steps above are followed. If the pump does not self prime, you can choose one of 2 ways to help prime:

1. Remove the AUTOPRIME™ valve and cartridges and slowly pour water or solution into the pump head until it is filled. Replace cartridges and AUTOPRIME™ valve and repeat steps above.
2. Temporarily improve suction conditions by pumping from a container closer to or above pump.

F. DEPRESSURIZING THE DISCHARGE LINE

ALWAYS wear protective clothing, face shield, safety glasses and gloves when performing any maintenance or replacement on your pump.

When preparing to maintain the pump or any component in the discharge line, the 4-function valve is used to depressurize the line. Be sure an injection check valve is properly installed and is operating, and that all tubing connections on the 4-function valve are secure.

Be sure your relief tubing is connected to your pressure relief port on the 4-function valve and runs back to your solution drum or tank.

1. Turn off the pump.
2. If any valves have been installed downstream of the pump, close them.
3. If the supply tank for the pump is higher than the pump head, fluid will flow through unless a suction line valve is closed.
4. Turn the black knob on the 4-function valve about 1/8 turn CCW to its open position. This relieves pressure between the pump and the 4-function valve.
5. To release line pressure, while the black knob is in the open position, turn the yellow knob and hold open until fluid flow through the bypass port stops.



When tubing connections are loosened, chemical will drain from the line. Use appropriate safety precautions to avoid contact with chemical.

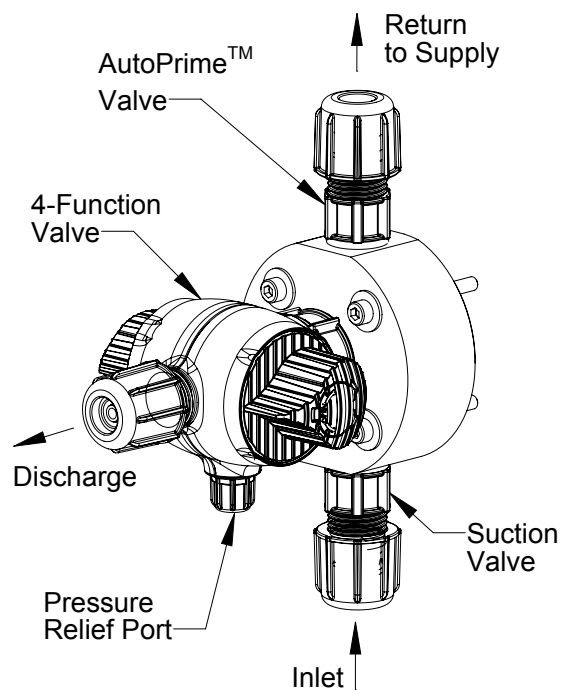

FIGURE 3

REFER TO YOUR ELECTRONIC METERING PUMP INSTRUCTION MANUAL FOR ADDITIONAL INSTRUCTIONS AND PRECAUTIONS. You may contact your local LMI Distributor for additional information or visit LMI on the web at www.lmipumps.com