



When pumping solutions, make certain that all tubing is securely attached to the fittings. It is recommended that tubing or pipe lines be shielded to prevent possible injury in case of rupture or accidental damage. Always wear protective clothing and face shield when working on or near your metering pump.

*Note: See parts list for materials of construction*

### A. INSTALLING INJECTION CHECK VALVE (FIGURE 1)

1. The Injection Check Valve prevents backflow from a treated line. Install the injection check valve at the location where chemical is being injected into the system.
2. Any size Female NPT fitting or pipe tee with a reducing bushing to 1/2" Female NPT will accept the injection check valve. PTFE tape should only be used on threads that are connected with pipes.
3. When installing the Injection Check Valve, be sure to position it so that the valve enters the bottom of your pipe in a vertical position. Variations 40° left and right are acceptable.

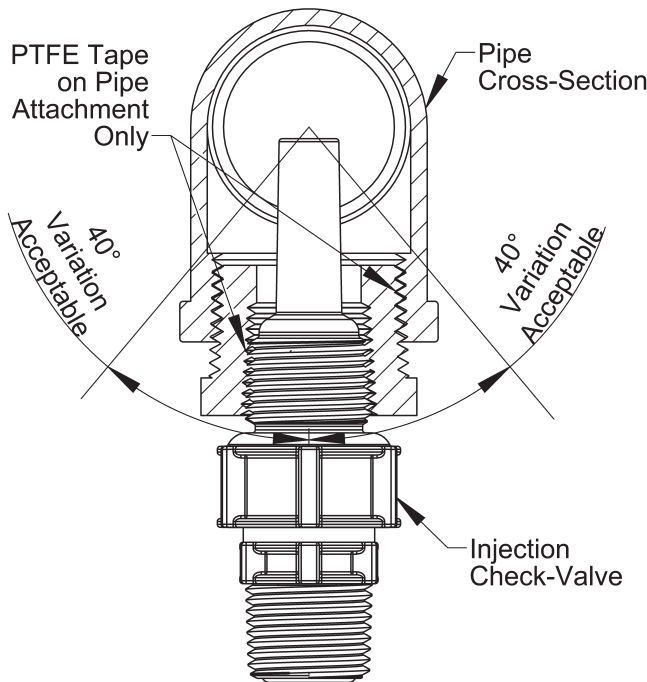

**FIGURE 1**

### B. CONNECTING DISCHARGE TUBING (FIGURE 2)

**Note:** Cut tubing to length needed for discharge line.

1. Route tubing from the injection check valve to the metering pump, making sure it does not touch hot or sharp surfaces, or is bent so sharply that it kinks.
2. Put coupling nut over tubing.

3. Position female Ferrule about one inch (25 mm) from end of tubing.
4. For 1/4" or 6 mm OD tubing, cut tubing so that 1/4" to 3/8" (5-10 mm) protrudes from the female Ferrule. For all other tubing push the tube to the bottom of the groove in the male Ferrule. Then slide the female Ferrule down into the male Ferrule.
5. Firmly hand tighten the coupling nut onto the fitting.

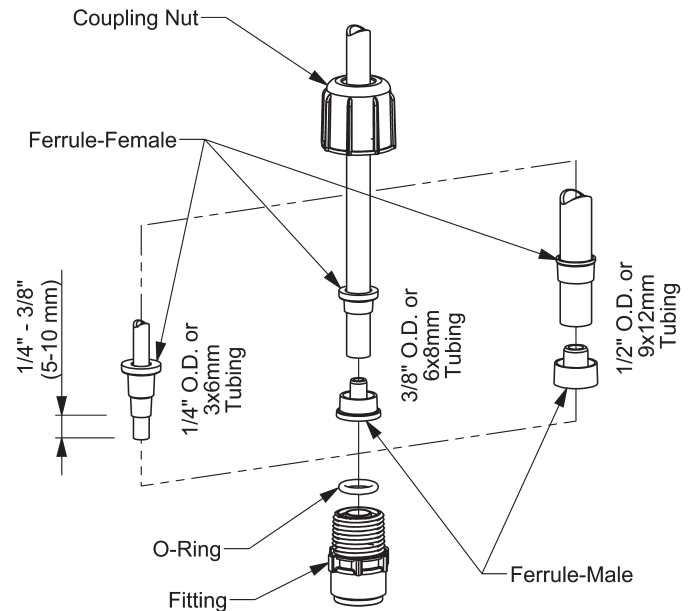

**FIGURE 2**

**DO NOT USE CLEAR VINYL TUBING ON THE DISCHARGE SIDE OF THE PUMP. The pressure created by the pump can rupture vinyl tubing, which is only for suction connections on certain liquid ends.**

**DO NOT USE PLIERS OR PIPE WRENCH ON COUPLING NUTS OR FITTINGS. USE ONLY LMI TUBING—ALWAYS use LMI supplied tubing with your pump, as the tubing is specifically designed for use with the pump fittings.**

### C. CONNECTING SUCTION TUBING

1. Cut suction tubing to a length so that the foot valve hangs just above the bottom of the solution container. Maximum recommended vertical suction lift is 5 ft (1.5m).
2. Follow same procedure in connecting suction tubing to suction valve and foot valve (see **B. Connecting Discharge Tubing**).

# LE—3X3NX

Key Number	Description	Part Number	QUANTITY			
			313NX	353NX	363NX	393NX
10	Pump Head	37980		1		
		37979				1
		38543			1	
		36128	1			
40	O-Ring	48591	4	4	4	4
90	O-Ring	39413	4	4	4	4
100	O-Ring	48589	4	4	4	4
190	Liquifram™	30916		1		
		30917				1
		31420			1	
		31419	1			
230	Injection Valve Body	48618	1	1	1	1
250	Ceramic Weight	10322	1	1	1	1
260	Foot Valve Coupling	36204	1	1	1	1
270	Foot Valve Strainer	10123	1	1	1	1
350	Tubing, Suction & Discharge <b>3XXNI ONLY</b>	25636-16		1		
		10342-16			1	1
		10142-16	1			
	Tubing, Suction & Discharge <b>3XXNU ONLY</b>	28636-16		1		
		27342-16			1	1
		27142-16	1			
602	Check Valve	49091		2		
		49092	2		2	2
603	Cartridge Valve	37334		3		
		37337	3		3	3
606	Liquid End Hardware	49110		1	1	1
		49111	1			
607	Foot Valve	49103		1		
		49104	1		1	1
608	Injection Valve	48732	1	1	1	1
613	Tubing Connection Kit <b>3XXNI and 3XXNU</b>	77382		4		
		77383			4	4
		77384	4			
	Tubing Connection Kit <b>3XXNM ONLY</b>	77378		4		
		77379			4	4
		77380	4			
615	Check Valve Fitting	48789	4	4	4	4
617	Injection Valve Cartridge	48795	1	1	1	1

# LE-3X3NX

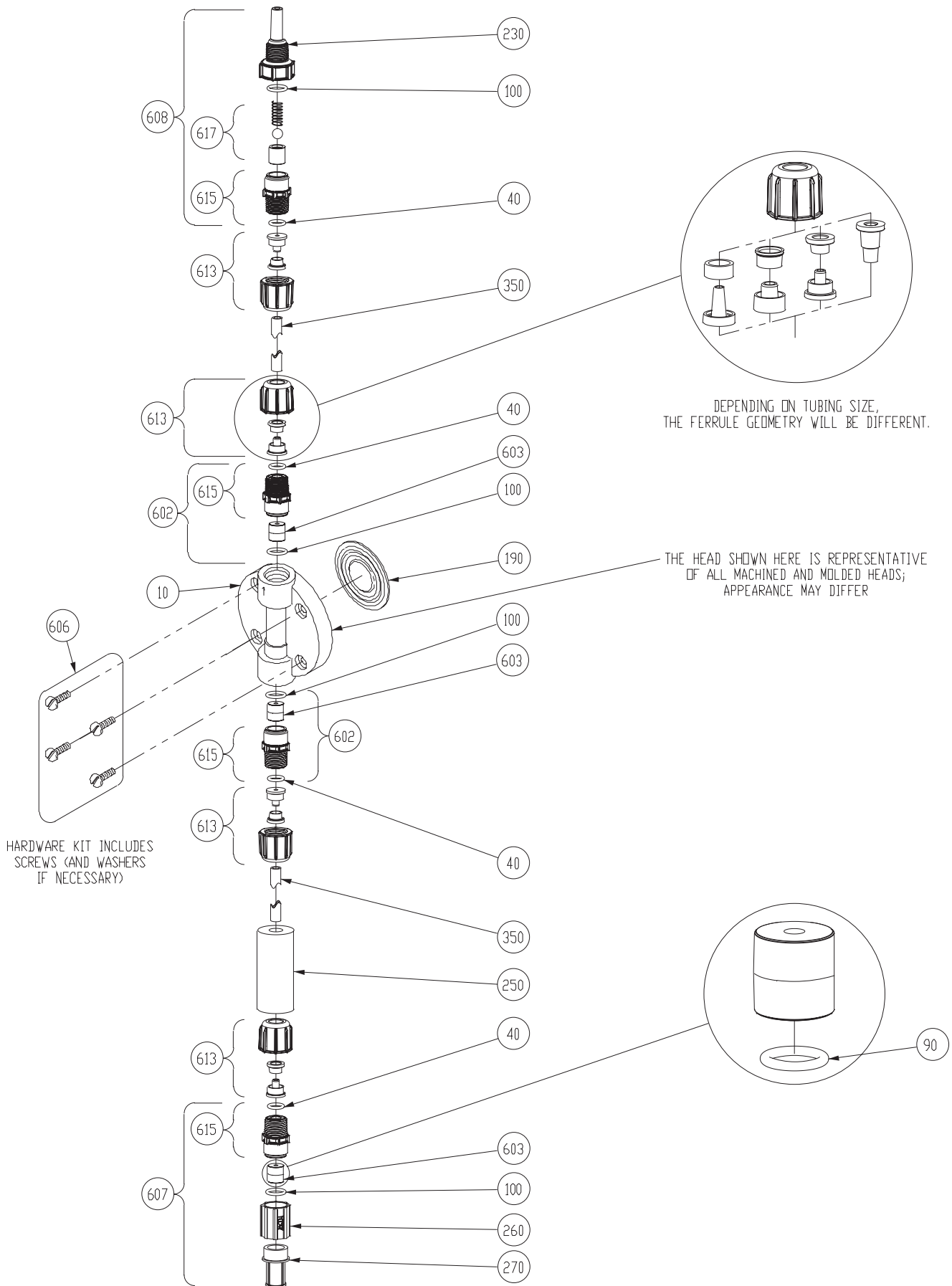

## D. PRIMING

When all precautionary steps have been taken, the pump is mounted, and the tubing is securely attached, you may now start priming the pump.

1. Plug in or switch the pump on.
2. While the pump is running, set at 100% speed and 100% stroke length.
3. The suction tubing should begin to fill with solution from the tank.
4. A small amount of solution will begin to discharge out the discharge valve. Once this happens, **SHUT THE PUMP OFF.**
5. The pump is now primed.

**Note:** *The pumps are normally self priming if suction lift is less than 5 feet (1.5 meters), check valves are wet (there is usually water in the pump head when shipped from the factory), and the steps above are followed. If the pump does not self prime, you can choose one of 2 ways to help prime:*

1. Remove the discharge valve and discharge cartridge and slowly pour water or solution into the pump head until it is filled. Replace cartridge and discharge valve and repeat steps above.
2. Temporarily improve suction conditions by pumping from a container closer to or above pump.

## E. DEPRESSURIZING THE DISCHARGE LINE

**ALWAYS wear protective clothing, face shield, safety glasses and gloves when performing any maintenance or replacement on your pump.**

**Read steps 1 and 2 below before proceeding.**

1. Be sure the Injection Check Valve is properly installed and is operating. If a shut off valve has been installed downstream of the Injection Valve, it should be closed.

### 2. Line Depressurization:

To reduce the risk of chemical splash during disassembly or maintenance, all installations should be equipped with line depressurization capability. Installing a 4-Function Valve is one way to include this capability. Refer to the operating instructions of the valve or device.



**When tubing connections are loosened, chemical will drain from the line. Use appropriate safety precautions to avoid contact with chemical.**

**REFER TO YOUR ELECTRONIC METERING PUMP INSTRUCTION MANUAL FOR ADDITIONAL INSTRUCTIONS AND PRECAUTIONS.** You may contact your local LMI Distributor for additional information or visit LMI on the web at [www.lmipumps.com](http://www.lmipumps.com)