



Griffco Valve Inc.
 6010 N. Bailey Ave., Suite 1B
 Amherst, NY 14226
 Phone: 1 716 835-0891
 Fax: 1 716 835-0893

INJECTION VALVE

Installation and Operation Manual

Installation Instructions:

1. Install the Injection Valve at the injection port so that the quill tip is close to the center of the pipe.
2. If there is a 45° angle inclined edge, for clean liquids, the angle should face the flow as shown in the figure below. For slurries and other like fluids that can clog the tip, make sure it is opposite the flow. This is achieved by tightening the valve all the way, until the arrow on the valve body faces the desired direction. (note arrow direction before installing)
3. Use PTFE tape or pipe dope to prevent potential leaks.
4. Do not over tighten.
5. Connect chemical feed line to opposite end. It is recommended to connect to the chemical system pipe with a flexible line for ease of installation and maintenance.

Operation:

Griffco injection valves are threaded into the middle of a process pipe to deliver chemical to a desired application point. The integrated quill keeps the chemical off the wall of the pipe and will ensure better mixing of the chemical with the process fluid. This is enhanced by the 45° angle at the quill tip. The ball check in the valve functions as a positive shut-off to ensure the process fluid does not go back up the chemical line.

Maintenance:

The injection valves were designed for minimizing the amount of maintenance required to keep the valves in operation. However, periodic replacement of the internal components is required. Contact your local Griffco Valve distributor for parts or with service questions. To facilitate inspection and replacement, the valve layout is such that inspection and removal of the ball, spring and o'ring can be done without taking the valve out of the chemical line.

Caution: Ensure the system is not under pressure and that the chemical lines are flushed with water before disassembly. Unscrew the union nut to allow for inspection of the internals. After replacement, screw the union nut back in position.

CAUTION: DO NOT OVER-TIGHTEN!



Sectional Drawing:

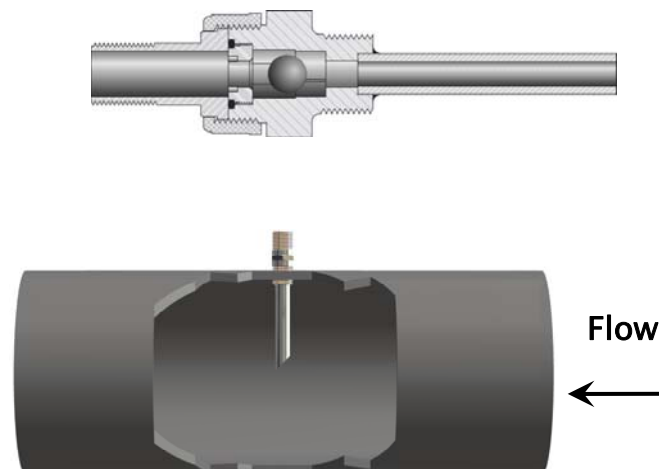

Technical Data:

Sizes: Model ICV	1/2", 3/4", 1", 1.5", and 2"
Connections:	Union – Threaded (Metal & Plastic) or Socket (Plastic Only)
Maximum Temperature (°F)	Plastic: 140° ; Metal: 300°
Maximum Operating Pressure	Plastic: 250 psi ; Metal: 350 psi
Materials of Construction:	
Valve Ball / Spring	PTFE Ball / Hastelloy C Spring
O Ring	Standard: FKM (Viton®) Optional: EPDM
Union Nut	Standard: PVC for plastic valves. 316 SS for metal valves Optional: Others on Request
Valve Body	PVC, CPVC, PP, PVDF, 316 SS, A 20, Hast. C, Others on Request
Optional Injection Tip	Contact Factory for details

