

CR, CRN 95-255

North America

Vertical, multistage centrifugal pumps



1. Product introduction	3	11. Grundfos Product Center	53
Typical applications	3	Grundfos GO Remote	54
Pump Energy Index (PEI).	4		
Features and benefits	4		
Terminal box positions	6		
Viscosity	6		
2. Performance range	7		
3. Product range.	8		
4. Identification.	9		
Type key	9		
5. Construction.	11		
CR 95, 125, 155, 185, 215, 255	11		
CRN 95, 125, 155, 185, 215, 255	12		
6. Operating conditions.	13		
Pumped liquids	13		
Maximum operating pressure and liquid temperature	16		
Operating range of the shaft seal	17		
Maximum inlet pressure	18		
7. Selection and sizing.	19		
Selection of pump	19		
How to read the curve charts	22		
Guidelines to performance curves	23		
8. Performance curves and technical data.	24		
CR 95	24		
CRN 95	26		
CR 125	28		
CRN 125	30		
CR 155	33		
CRN 155	35		
CR 185	37		
CRN 185	39		
CR 215	41		
CRN 215	43		
CR 255	45		
CRN 255	47		
9. Motor data	49		
Standard motors in the CR 95-255 range	49		
TEFC motors	50		
ODP motors	51		
10. Accessories	52		
PJE couplings for CRN	52		

1. Product introduction

This data booklet covers Grundfos CR and CRN pumps with these nominal flow sizes:

- CR, CRN 95, 125 and 155
- CR, CRN 185, 215 and 255.

Options for smaller flow sizes are described in the data booklet for CR, CRI, CRN, 60 Hz NEMA available on Grundfos Product Center at <http://net.grundfos.com/qr/i/98446676>



TM069062

CR, CRN 95-255

Typical applications

The pumps are suitable for numerous applications. The following applications are some typical examples.

Water supply:

- Filtration and transport waterworks
- Distribution from waterworks
- Pressure boosting of mains.

Industrial:

- Pressure boosting
- Process water transfer
- Boiler feed
- Cooling and air conditioning
- Firefighting systems
- Special liquids transfer.

Water treatment:

- Filtration
- Brackish water reverse osmosis.

Commercial building services:

- Chilled-water systems
- Hot-water systems
- Pressure boosting
- Boiler feed
- Firefighting systems
- District energy systems.

Pump Energy Index (PEI)

Pump Energy Index (PEI) was established by the U.S. Department of Energy (DOE) and adopted by Canada as the standard metric used to evaluate pump efficiency. The value is the ratio of the pump efficiency rating (PER) divided by the calculated minimally compliant PER (PER_{STD}) for the pump type. This provides a representation of a pump's actual performance compared to the minimal standard performance required by regulation. The lower the PEI value, the more efficient a pump is at the tested operating points.

PER is determined by defined testing parameters required by the DOE. This includes testing a particular pump model at its best efficiency point (BEP).

For PEI values there are two different versions:

- PEI_{CL} (constant load): Applies to a bare-shaft pump and a pump sold with a motor
- PEI_{VL} (variable load): Applies to pumps sold with a motor and controller (such as VFD, VSD)

The DOE has set the maximum PEI value as 1.00. Any pump, pump and motor, or pump, motor and controller that exceeds a PEI value of 1.00 can no longer be manufactured after January 26, 2020.

PEI is a generalized efficiency value. PEI cannot be used to determine the efficiency of a pump in a specific application.

PEI values for CR 95-255

Product type	Poles	PEI_{CL} bare-shaft pump	PEI_{CL} pump with motor	PEI_{VL} pump with motor plus controller ¹	Impeller diameter [[in (mm)]]
CR, CRN 95	2	0.92	0.93	0.45	6.07
	4	0.94	0.94	0.47	(154)
CR, CRN 125	2	0.92	0.93	0.59	6.38
	4	0.94	0.94	0.47	(162)
CR, CRN 155	2	0.93	0.93	0.59	6.64
	4	0.95	0.95	0.47	(169)
CR, CRN 185 ²⁾	4	0.95	0.95	0.46	7.36 (187)
CR, CRN 215 ²⁾	4	0.96	0.96	0.47	7.80 (198)
CR, CRN 255 ²⁾	4	0.97	0.97	0.48	7.72 (196)

¹⁾ Grundfos CUE continuous controls.

²⁾ 2-pole CR, CRN 185, 215, 255: Out of scope for DOE PEI.

Features and benefits

CR, CRN pumps are vertical multistage, centrifugal pumps. The in-line design of the pumps enables installation in a horizontal one-pipe system where the inlet and outlet ports are in the same horizontal level and have the same pipe dimensions. This design provides a more compact pump design.

The pumps are available in various sizes and various numbers of stages to deliver the flow and pressure required.

CR, CRN pumps are designed for a variety of applications ranging from the pumping of potable water to the pumping of chemicals. The pumps are therefore suitable for a wide diversity of pumping systems where the performance and material of the pump meet specific demands.

A CR, CRN pump consists of two main components: the motor and the pump unit.

The pump unit consists of optimized hydraulics, various types of connections, a sleeve, a pump head and various other parts.

CR, CRN pumps are available in various material versions according to the pumped liquid.

CR pumps fitted with EPDM elastomers are compliant with ANSI/NSF 61 and ANSI/NSF 372. See UL file MH26400 or contact Grundfos.

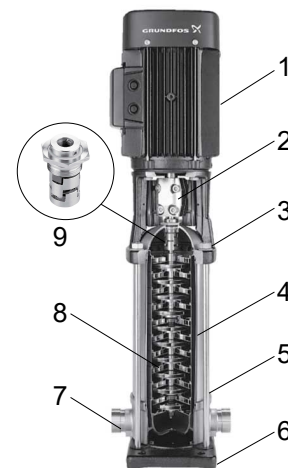

CR pump

Pos.	Description
1	Motor
2	Coupling
3	Pump head
4	Sleeve
5	Staybolts
6	Base plate
7	Base
8	Impellers
9	Shaft seal (cartridge type)

Related information

[Type key](#)

TM078847

Pump

The CR pumps are non-self-priming, vertical multistage centrifugal pumps.

The pump consists of a base and a pump head. Staybolts secure the chamber stack and sleeve between the pump head and base. The base has inlet and outlet ports on the same level (in line). All pumps are fitted with a maintenance-free cartridge type shaft seal that can be changed without removal of motor or disassembly of the pump.

Motors

CR and CRN pumps are fitted with a Grundfos specified motor. The motors are all heavy-duty 2-pole, NEMA C-face motors (D-face for 100 HP motors and larger).

The pumps are supplied with WEG motors as standard. Grundfos ML motors (15 to 30 HP, TEFC three-phase) are available on request.

Angular contact bearings are fitted to the drive end on motors up to 75 HP (55 kW). This ensures that the motor bearing life (L10) is extended to match that of the pump.

Electrical data

Mounting designation	NEMA
Insulation class	F
Efficiency	Premium efficiency - EISA compliant
Enclosure	IP55 TEFC - Totally Enclosed Fan Cooled.
60 Hz standard voltages	3 x 208-230/460 V 3 x 575 V
Number of poles	2

Approvals, WEG



Approvals, Grundfos ML



Grundfos E-motors

We also offer frequency-controlled CRE pumps which are the ideal choice for a number of applications characterized by a demand for a variable flow rate at a constant pressure. These pumps are suited for water supply systems and pressure boosting as well as for industrial applications. Depending on the application, the pumps offer energy savings, increased comfort and improved processing. See the CRE, CRIE, CRNE product guide available in Grundfos Product Center at <http://product-selection.grundfos.com/>.

Optional motors

The Grundfos standard range of motors covers a wide variety of application demands. However, for special applications or operating conditions, custom-built motor solutions can be provided.

For special applications or operating conditions, Grundfos offers custom-built motors such as:

- explosion-proof motors
- motors with anti-condensation heating unit
- motors with thermal protection.

Motor protection

Three-phase motors must be connected to a motor-protective circuit breaker according to local regulations.

Three-phase Grundfos ML motors 5 HP (3.7 kW) and larger have a built-in thermistor (PTC) according to DIN 44082 (TP 211 according to IEC 34-11).

WEG motors 0.25 to 20 HP

- rolled steel construction
- service factor 1.15
- suitable for VFD operation per NEMA MG 1 part 31.4.4.2
- certified Class I Division 2, Groups A, B, C, D
- certified Class II, Division 2, Groups F, G (three-phase only).

WEG motors 25 to 300 HP

- cast iron frame
- rated for severe duty
- service factor 1.25 (25 to 100 HP)
- service factor 1.15 (125 to 300 HP)
- Inverter rated per NEMA MG 1 part 31
- certified Class I Division 2, Groups A, B, C, D
- certified Class II, Division 2, Groups F, G.

Terminal box positions

As standard, the terminal box is fitted on the inlet side of the pump.

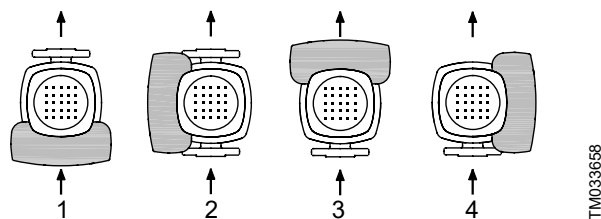

TM033658

Terminal box positions

Pos.	Description
1	6 o'clock position (standard)
2	9 o'clock position
3	12 o'clock position
4	3 o'clock position

Viscosity

Pumping liquids with densities or kinematic viscosities higher than those of water will cause a considerable pressure drop, a drop in the hydraulic performance and a rise in the power consumption.

In such situations, the pump must be fitted with a larger motor. If in doubt, contact Grundfos.

2. Performance range

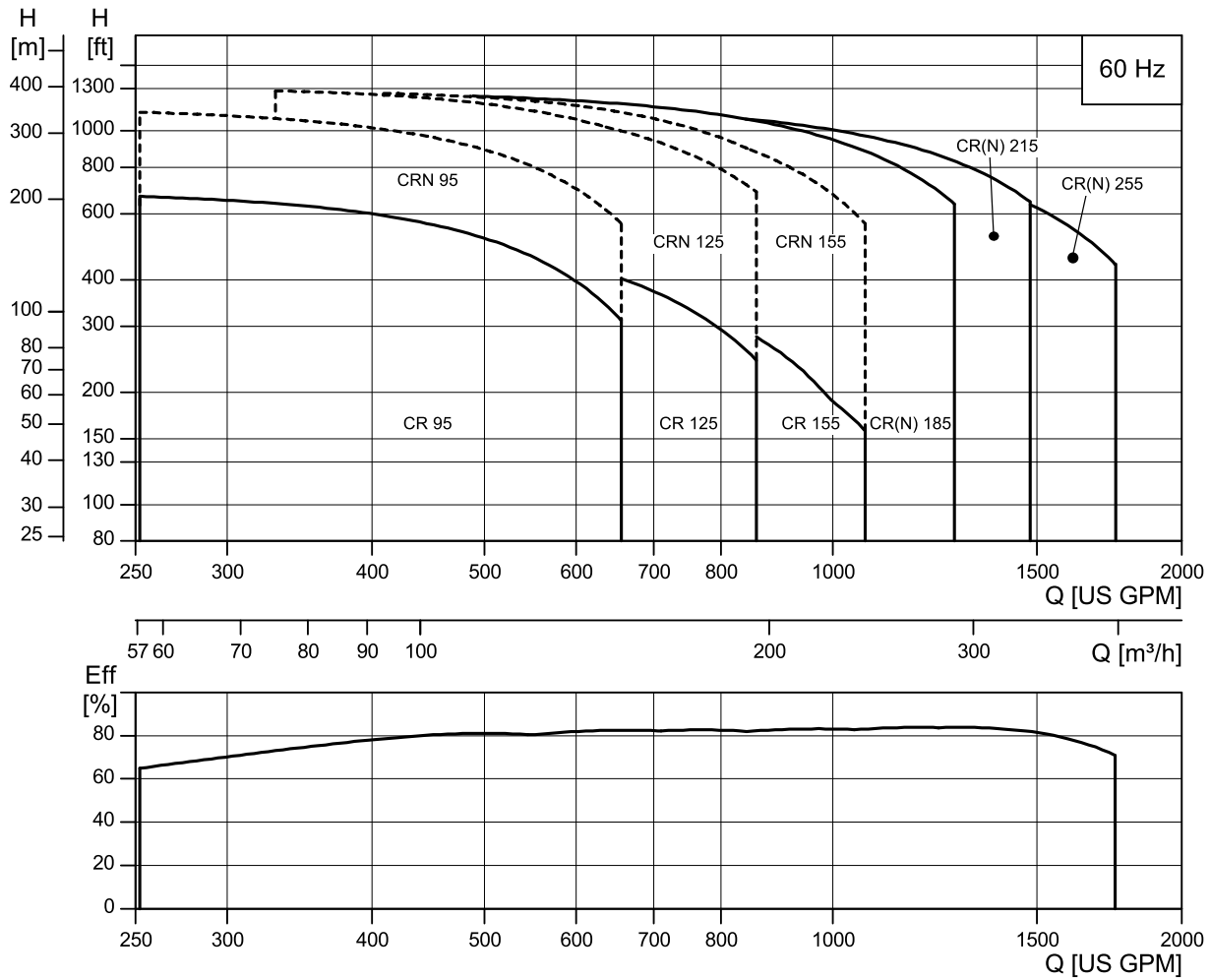

TM065583

Performance range, CR, CRN

3. Product range

CR, CRN pump size	95	125	155	185	215	255
Rated flow rate [US gpm (m ³ /h)]	500 (114)	660 (150)	820 (186)	980 (222)	1135 (258)	1350 (307)
Flow range [US gpm]	250-650	330-860	410-1060	490-1270	570-1480	675-1755
Minimum liquid temperature [°F (°C)]	-4 (-20) ³⁾	-4 (-20) ³⁾	-4 (-20) ³⁾	-4 (-20) ³⁾	-4 (-20) ³⁾	-4 (-20) ³⁾
Maximum liquid temperature [°F (°C)]	248 (120) ⁴⁾	248 (120) ⁴⁾	248 (120) ⁴⁾	248 (120) ⁴⁾	248 (120) ⁴⁾	248 (120) ⁴⁾
Maximum pump efficiency [%]	81	82	82	82	84	84
Maximum developed pressure [psi (bar)]	300 (21) ⁵⁾	435 (30) ⁵⁾	370 (26) ⁵⁾	560 (39)	525 (36.1)	395 (27.2)
Motor power [HP]	15-125	20-200	25-250	40-300	50-300	60-300
Standard versions						
CR:						
Cast iron and stainless steel EN 1.4301/AISI 304	•	•	•	•	•	•
CRN:						
Stainless steel EN 1.4401/AISI 316	•	•	•	•	•	•
CR pipe connection						
ANSI flange size	4" ANSI	6" ANSI	6" ANSI	8" ANSI	8" ANSI	8" ANSI
ANSI flange class	150/300 lb.	150/300 lb.	150 lb.	150/300 lb.	150/300 lb.	150/300 lb.
CRN pipe connection						
ANSI flange size	4" ANSI	6" ANSI	6" ANSI	8" ANSI	8" ANSI	8" ANSI
ANSI flange class	150/300 lb.	150/300 lb.	150/300 lb.	150/300 lb.	150/300 lb.	150/300 lb.
PJE coupling (Victaulic type)	4"	6"	6"	8"	8"	8"

3) CRN 95-255: Minimum liquid temperature down to -40 °F (-40 °C) is available on request.

4) CR, CRN 95-255: For operating pressures above 363 psi (25 bar) the liquid temperature limits are -4 to +176 °F (-20 to +80 °C).

5) CR 95-155: Maximum operating pressure is 363 psi (25 bar). CRN 95-155: Maximum operating pressure is 580 psi (40 bar). Note that CRN 95 pumps with motors above 75 HP and CRN 125-155 pumps with motors above 150 HP require a soft starter or frequency converter.

• Available as standard.

4. Identification

Type key

Example

CRE 95-1-1 A-G-A-E-HQQE-N-C-B

Code	Explanation
CR	Type range: CR, CRI, CRN, CRT
E	Pump with integrated frequency converter
95	Flow rate (nominal, 50 Hz) [m ³ /h]
1	Number of impellers
1	Number of reduced-diameter impellers
A	Code for pump version
G	Code for pipe connection
A	Code for materials
E	Code for rubber parts
	Code for shaft seal:
H	• Shaft seal type designation
Q	• Seal face material (rotating seal face)
Q	• Seal face material (stationary seal face)
E	• Secondary seal material (rubber parts)
N	Code for motor: P2 [HP (kW)]
C	Code for motor: phase and voltage [V]
B	Code for motor: speed variant [rpm]

Key to codes

Code	Description
Pump version	
A	Basic version
B	Oversize motor
C	CR compact
D	Pump with pressure intensifier
E	Pump with certificate
F	Pump for high temperatures (with air-cooled top)
G	E-pump without operating panel
H	Horizontal version
I	Different pressure rating
J	E-pump with a different maximum speed
K	Pump with low NPSH
L	Pump including Grundfos CUE and certificate
M	Magnetic drive
N	With sensor
O	Cleaned and dried
P	Undersize motor
Q	High-pressure pump with high-speed MGE motor
R	Belt-driven pump
S	High-pressure pump
T	Thrust handling device
U	ATEX-approved pump
V	Cascade function

Code	Description
W	Deep-well pump with ejector
X	Special version
6	Special version with NSF 61/372 approval
Y	Electropolished
Z	Pumps with bearing flange

Pipe connection	
A	Oval flange
B	NPT thread
CA	FlexiClamp
CX	TriClamp
F	DIN flange
FC	DIN 11853-2 flange (collar flange)
FE	EN 1092-1, type E
G	ANSI flange
J	JIS flange
N	Changed diameter of ports
P	PJE coupling (Victaulic type)
X	Special version

Materials	
A	Basic version
C	Carbon-free pump
D	Carbon-graphite-filled PTFE (bearings)/tungsten carbide
E	Pickled and passivated (Only Japan)
H	Flanges and base plate EN 1.4408
K	Bronze (bearings)/tungsten carbide
L	Motor stool, base plate and flanges EN 1.4408
M	Motor stool, base plate, coupling and flanges EN 1.4408 and coupling guards in cobber. Bolts, nuts and spacing pipes EN 1.4401 or higher grade
N	Flanges EN 1.4408
P	PEEK neck ring
Q	Silicon carbide/silicon carbide bearing in pump and silicon carbide/silicon carbide seal faces in thrust handling device
R	Silicon carbide/silicon carbide bearing
S	PTFE neck rings
T	Base plate EN 1.4408
U	Silicon carbide/silicon carbide bearing in pump and silicon carbide/tungsten carbide seal faces in thrust handling device
W	Tungsten carbide/tungsten carbide
X	Special version

Rubber parts in pump	
E	EPDM
F	FXM (Fluoraz [®])
K	FFKM (Kalrez [®])
N	CR (Neoprene)
V	FKM (Viton [®])

Shaft seal type designation	
A	O-ring seal with fixed driver
H	Balanced cartridge seal with O-ring

Code	Description
O	Double seal, back-to-back
P	Double seal, tandem
X	Special version
Seal face material (rotating and stationary seal face)	
B	Carbon, synthetic resin-impregnated
U	Cemented tungsten carbide
Q	Silicon carbide
X	Other ceramics
Secondary seal material (rubber parts)	
E	EPDM
F	FXM (Fluoraz [®])
K	FFKM (Kalrez [®])
V	FKM (Viton [®])

Codes for motor

Code	Description
P2 [HP (kW)]	
C	0.33 (0.25)
D	0.5 (0.37)
E	0.75 (0.55)
F	1 (0.75)
G	1.5 (1.1)
H	2 (1.5)
I	3 (2.2)
K	5 (4)
L	7.5 (5.5)
M	10 (7.5)
N	15 (11)
O	20 (15)
P	25 (18.5)
Q	30 (22)
R	40 (30)
S	50 (37)
T	60 (45)
U	75 (55)
V	100 (75)
W	120 (90)
1	150 (110)
2	175 (132)
3	215 (160)
4	270 (200)
5	335 (250)
Phase and voltage (V)	
A	1 × 200-240 V
B	3 × 200-240 V
C	3 × 440-480 V
D	3 × 380-500 V
X	Not defined
Speed variant (rpm)	
A	1450-2000
B	2900-4000
C	4000-5900
2	2-pole
4	4-pole

5. Construction

CR 95, 125, 155, 185, 215, 255

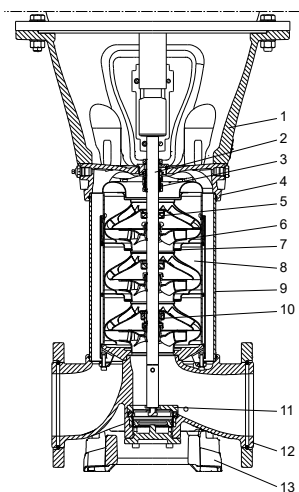

TM065161

Materials, CR

Pos.	Designation	Materials	DIN/EN	≈ AISI/ASTM
1	Motor stool	Ductile cast iron	EN 1563 EN-GJS-500-7	ASTM A536-84 65-45-12
2	Shaft	Stainless steel	EN 10088 1.4057 ⁶⁾ EN 10088 1.4462 ⁷⁾	AISI 431 ⁶⁾ AISI 318 LN ⁷⁾
3	Shaft seal (seal faces)	Silicon carbide/silicon carbide	-	-
4	Pump head	Ductile cast iron	EN 1563 EN-GJS-500-7	ASTM A536-84 65-45-12
5	Support bearing (bush)	Carbon-graphite-filled PTFE		
6	Impeller	Stainless steel	EN 10088 1.4301 EN 10088 1.4401 ⁸⁾	AISI 304 AISI 316 ⁸⁾
7	Neck ring	PEEK	-	-
8	Chamber	Stainless steel	EN 10088 1.4301 EN 10088 1.4401 ⁸⁾	AISI 304 AISI 316 ⁸⁾
9	Sleeve	Stainless steel	EN 10088 1.4301 ⁶⁾ EN 10088 1.4404 ⁷⁾	AISI 304 ⁶⁾ AISI 316 L ⁷⁾
10	Bearing ring	Tungsten carbide/tungsten carbide	-	-
11	Thrust handling device ⁹⁾	Stainless steel	EN 10088 1.4401 EN 10283 1.4408	AISI 316 CF 8M equal to AISI 316
		Silicon carbide/tungsten carbide	-	-
12	Base	Ductile cast iron	EN 1563 EN-GJS-500-7	ASTM A536-84 65-45-12
13	Base plate	Ductile cast iron	EN 1563 EN-GJS-500-7	ASTM A536-84 65-45-12
		Staybolts	Stainless steel	EN 10088 1.4057

⁶⁾ CR 95.

⁷⁾ CR 125, 155, 185, 215, 255. Shaft is made of duplex stainless steel.

⁸⁾ CR 185, 215, 255.

⁹⁾ If fitted.

CRN 95, 125, 155, 185, 215, 255

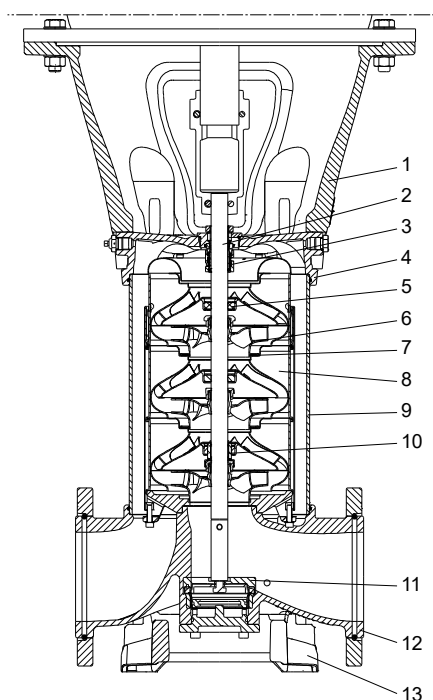

TM065161

Materials, CRN

Pos.	Designation	Materials	DIN/EN	≈ AISI/ASTM
1	Motor stool	Ductile cast iron	EN 1563 EN-GJS-500-7	ASTM A536-84 65-45-12
2	Shaft	Stainless steel	EN 10088 1.4462 ¹⁰⁾	318 LN
3	Shaft seal (seal faces)	Silicon carbide/silicon carbide	-	-
4	Pump head	Stainless steel	EN 10283 1.4408	CF 8M
5	Support bearing (bush)	Carbon-graphite-filled PTFE	-	-
6	Impeller	Stainless steel	EN 10088 1.4401	AISI 316
7	Neck ring	PEEK	-	-
8	Chamber	Stainless steel	EN 10088 1.4401	AISI 316
9	Sleeve	Stainless steel	EN 10088 1.4404	AISI 316 L
10	Bearing ring	Tungsten carbide/tungsten carbide	-	-
11	Thrust handling device ¹¹⁾	Stainless steel	EN 10088 1.4401 EN 10283 1.4408	AISI 316 CF 8M equal to AISI 316
		Silicon carbide/tungsten carbide	-	-
12	Base	Stainless steel	EN 10283 1.4408	CF 8M
13	Base plate	Ductile cast iron	EN 1563 EN-GJS-500-7	ASTM A536-84 65-45-12
		Staybolts	Stainless steel	EN 10088 1.4057

¹⁰⁾ Duplex stainless steel

¹¹⁾ If fitted.

6. Operating conditions

Pumped liquids

The pumps are suitable for pumping thin, non-explosive liquids, not containing solid particles or fibers. The liquid must not attack the pump materials.

CR pumps are suitable for non-corrosive liquids and are to be used for liquid transfer, circulation and pressure boosting of cold or hot clean water.

CRN pumps are suitable for industrial liquids and are to be used in systems where all parts in contact with the liquid must be made of high-grade stainless steel.

List of pumped liquids

A number of typical liquids are listed below.

Other pump versions may be applicable, but those stated in the list are considered to be the best choices.

The table is intended as a general guide only and cannot replace actual testing of the pumped liquids and pump materials under specific working conditions.

Therefore, use the list with some caution. Factors such as those mentioned below may affect the chemical resistance of a specific pump version:

- concentration of the pumped liquid
- liquid temperature
- pressure.

Take safety precautions when pumping dangerous liquids.

Notes

D	Often with additives.
E	The density and/or viscosity differ from that/those of water. Take this factor into account when calculating motor output and pump performance.
F	Pump selection depends on many factors. Contact Grundfos.
H	Risk of crystallization/precipitation in shaft seal.
1	Highly flammable liquid.
2	Combustible liquid.
3	Insoluble in water.
4	Low self-ignition point.

Pumped liquid	Chemical formula	Note	Liquid concentration, liquid temperature	CR	CRN
Acetic acid	CH ₃ COOH	-	5 %, 68 °F (20 °C)	-	HQQE
Acetone	CH ₃ COCH ₃	1, F	100 %, 68 °F (20 °C)	-	HQQE
Alkaline degreasing agent		D, F	-	HQQE	-
Ammonium bicarbonate	NH ₄ HCO ₃	E	20 %, 86 °F (86 °F (30 °C))	-	HQQE
Ammonium hydroxide	NH ₄ OH	-	20 %, 104 °F (40 °C)	HQQE	-
Aviation fuel		1, 3, 4, F	100 %, 68 °F (20 °C)	HQBV	-
Benzoic acid	C ₆ H ₅ COOH	H	0.5 %, 68 °F (20 °C)	-	HQQV
Boiler water		-	< 248 °F (120 °C)	HQQE	-
		F	248-356 °F (120-180 °C)	-	-
Calcareous water		-	< 194 °F (90 °C)	HQQE	-
Calcium acetate (as coolant with inhibitor)	Ca(CH ₃ COO) ₂	D, E	30 %, 122 °F (50 °C)	HQQE	-
Calcium hydroxide	Ca (OH) ₂	E	Saturated solution, 122 °F (50 °C)	HQQE	-
Chloride-containing water		F	< 86 °F (30 °C), maximum 500 ppm	-	HQQE
Chromic acid	H ₂ CrO ₄	H	1 %, 68 °F (20 °C)	-	HQQV
Citric acid	HOC(CH ₂ CO ₂ H) ₂ COOH	H	5 %, 104 °F (40 °C)	-	HQQE
Completely desalinated water (demineralized water)		-	248 °F (120 °C)	-	HQQE
Condensate		-	248 °F (120 °C)	HQQE	-
Copper sulphate	CuSO ₄	E	10 %, 122 °F (50 °C)	-	HQQE
Corn oil		D, E, 3	100 %, 176 °F (80 °C)	HQQV	-
Diesel oil		2, 3, 4, F	100 %, 68 °F (20 °C)	HQBV	-
Domestic hot water (potable water)		-	< 248 °F (120 °C)	HQQE	-
Ethanol (ethyl alcohol)	C ₂ H ₅ OH	1, F	100 %, 68 °F (20 °C)	HQQE	-
Ethylene glycol	HOCH ₂ CH ₂ OH	D, E	50 %, 122 °F (50 °C)	HQQE	-
Formic acid	HCOOH	-	5 %, 68 °F (20 °C)	-	HQQE
Glycerine (glycerol)	OHCH ₂ CH(OH)CH ₂ OH	D, E	50 %, 122 °F (50 °C)	HQQE	-
Hydraulic oil (mineral)		E, 2, 3	100 %, 212 °F (100 °C)	HQQV	-
Hydraulic oil (synthetic)		E, 2, 3	100 %, 212 °F (100 °C)	HQQV	-
Isopropyl alcohol	CH ₃ CHOHCH ₃	1, F	100 %, 68 °F (20 °C)	HQQE	-
Lactic acid	CH ₃ CH(OH)COOH	E, H	10 %, 68 °F (20 °C)	-	HQQV
Linoleic acid	C ₁₇ H ₃₁ COOH	E, 3	100 %, 68 °F (20 °C)	HQQV	-
Methanol (methyl alcohol)	CH ₃ OH	1, F	100 %, 68 °F (20 °C)	HQQE	-
Motor oil		E, 2, 3	100 %, 176 °F (80 °C)	HQQV	-
Naphthalene	C ₁₀ H ₈	E, H	100 %, 176 °F (80 °C)	HQQV	-
Nitric acid	HNO ₃	F	1 %, 68 °F (20 °C)	-	HQQE
Oil-containing water		-	< 212 °F (100 °C)	HQQV	-
Olive oil		D, E, 3	100 %, 176 °F (80 °C)	HQQV	-
Oxalic acid	(COOH) ₂	H	1 %, 68 °F (20 °C)	-	HQQE
Ozone-containing water	(O ₃)	-	< 212 °F (100 °C)	-	HQQE
Peanut oil		D, E, 3	100 %, 176 °F (80 °C)	HQQV	-
Petrol		1, 3, 4, F	100 %, 68 °F (20 °C)	HQBV	-
Phosphoric acid	H ₃ PO ₄	E	20 %, 68 °F (20 °C)	-	HQQE
Propanol	C ₃ H ₇ OH	1, F	100 %, 68 °F (20 °C)	HQQE	-
Propylene glycol	CH ₃ CH(OH)CH ₂ OH	D, E	50 %, 194 °F (90 °C)	HQQE	-
Potassium carbonate	K ₂ CO ₃	E	20 %, 122 °F (50 °C)	HQQE	-
Potassium formate (as coolant with inhibitor)	KOOCH	D, E	30 %, 122 °F (50 °C)	HQQE	-
Potassium hydroxide	KOH	E	20 %, 122 °F (50 °C)	-	HQQE
Potassium permanganate	KMnO ₄	-	5 %, 68 °F (20 °C)	-	HQQE

Pumped liquid	Chemical formula	Note	Liquid concentration, liquid temperature	CR	CRN
Rape seed oil		D, E, 3	100 %, 176 °F (80 °C)	HQQV	-
Salicylic acid	C ₆ H ₄ (OH)COOH	H	0.1 %, 68 °F (20 °C)	-	HQQE
Silicone oil		E, 3	100 %	HQQV	-
Sodium bicarbonate	NaHCO ₃	E	10 %, 140 °F (60 °C)	-	HQQE
Sodium chloride (as coolant)	NaCl	D, E	30 %, < 41 °F (5 °C), pH > 8	HQQE	-
Sodium hydroxide	NaOH	E	20 %, 122 °F (50 °C)	-	HQQE
Sodium hypochlorite	NaOCl	F	0.1 %, 68 °F (20 °C)	-	HQQV
Sodium nitrate	NaNO ₃	E	10 %, 140 °F (60 °C)	-	HQQE
Sodium phosphate	Na ₃ PO ₄	E, H	10 %, 140 °F (60 °C)	-	HQQE
Sodium sulphate	Na ₂ SO ₄	E, H	10 %, 140 °F (60 °C)	-	HQQE
Softened water		-	< 248 °F (120 °C)	-	HQQE
Soya oil		D, E, 3	100 %, 176 °F (80 °C)	HQQV	-
Sulphuric acid	H ₂ SO ₄	F	1 %, 68 °F (20 °C)	-	HQQV
Sulphurous acid	H ₂ SO ₃	-	1 %, 68 °F (20 °C)	-	HQQE
Unsalted swimming-pool water		-	Approx. 2 ppm free chlorine (Cl ₂)	HQQE	-

Maximum operating pressure and liquid temperature

ANSI, PJE (Victaulic type)

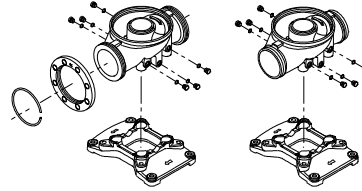

TM069402

Pump type	ANSI flange class	Maximum permissible operating pressure in standard configurations ¹²⁾ [psi (bar)]	Minimum liquid temperature [°F (°C)]	Maximum liquid temperature [°F (°C)]
CR 95-1-1 → 95-4-1	150	232 (16)	-4 (-20)	248 (120)
CR 95-4 → 95-5-1	300	363 (25)	-4 (-20)	248 (120)
CR 125-1-1 → 125-3	150	232 (16)	-4 (-20)	248 (120)
CR 125-4-2	300	363 (25)	-4 (-20)	248 (120)
CR 155-1-1 → 155-3-2	150	232 (16)	-4 (-20)	248 (120)
CR 185-1-1 → 185-2	150	232 (16)	-4 (-20)	248 (120)
CR 185-3-3 → 185-4-2	300	363 (25)	-4 (-20)	248 (120)
CR 185-4-1 → 185-6	300	580 (40)	-4 (-20)	248 (120) ¹³⁾
CR 215-1-1 → 215-2	150	232 (16)	-4 (-20)	248 (120)
CR 215-3-3 → 215-4-3	300	363 (25)	-4 (-20)	248 (120)
CR 215-4-2 → 215-5-1	300	580 (40)	-4 (-20)	248 (120) ¹³⁾
CR 255-1-1 → 255-2-1	150	232 (16)	-4 (-20)	248 (120)
CR 255-2 → 255-3	300	363 (25)	-4 (-20)	248 (120)
CR 255-4-3 → 255-4-1	300	580 (40)	-4 (-20)	248 (120) ¹³⁾
CRN 95-1-1 → 95-4-1	150	232 (16)	-4 (-20)	248 (120)
CRN 95-5-2 → 95-5-1	300	363 (25)	-4 (-20)	248 (120)
CRN 95-6-3 → 95-8	300	580 (40)	-4 (-20)	248 (120) ¹³⁾
CRN 125-1-1 → 125-3	150	232 (16)	-4 (-20)	248 (120)
CRN 125-4-2	300	363 (25)	-4 (-20)	248 (120)
CRN 125-4-1 → 125-9-3	300	580 (40)	-4 (-20)	248 (120) ¹³⁾
CRN 155-1-1 → 155-3-2	150	232 (16)	-4 (-20)	248 (120)
CRN 155-3-1 → 155-8-3	300	580 (40)	-4 (-20)	248 (120) ¹³⁾
CRN 185-1-1 → 185-2	150	232 (16)	-4 (-20)	248 (120)
CRN 185-3-3 → 185-4-2	300	363 (25)	-4 (-20)	248 (120)
CRN 185-4-1 → 185-6	300	580 (40)	-4 (-20)	248 (120) ¹³⁾
CRN 215-1-1 → 215-2	150	232 (16)	-4 (-20)	248 (120)
CRN 215-3-3 → 215-4-3	300	363 (25)	-4 (-20)	248 (120)
CRN 215-4-2 → 215-5-1	300	580 (40)	-4 (-20)	248 (120) ¹³⁾
CRN 255-1-1 → 255-2-1	150	232 (16)	-4 (-20)	248 (120)
CRN 255-2 → 255-3	300	363 (25)	-4 (-20)	248 (120)
CRN 255-4-3 → 255-4-1	300	580 (40)	-4 (-20)	248 (120) ¹³⁾

¹²⁾ For operating conditions outside the standard, contact Grundfos.

¹³⁾ For operating pressures above 363 psi (25 bar) the liquid temperature limits are -4 to 176 °F (-20 to 80 °C). See section on operating range of the shaft seal.

Operating range of the shaft seal

All pumps will be delivered with a HQQE/V cartridge shaft seal as standard.

The operating range of the shaft seal depends on operating pressure, pump type, type of shaft seal and liquid temperature. The operating range of standard shaft seals applies to clean water and water with anti-freeze liquids. For selection of the right shaft seal, see section about pumped liquids. If the operating range is exceeded, the life of the shaft seal may be reduced.

Related information

[List of pumped liquids](#)

CR, CRN 95-255

Ø22 shaft seals for 15-75 HP (11-55 kW)

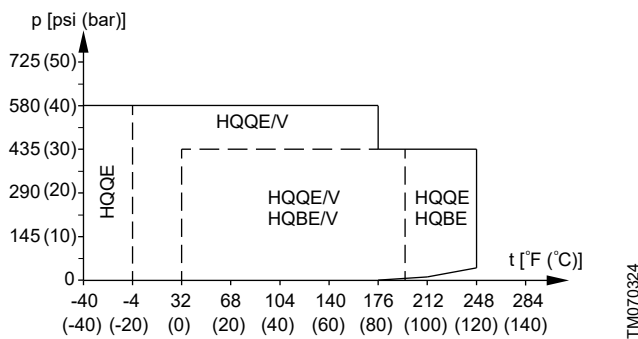

Operating range of standard shaft seals for CR, CRN 95-255, 15-75 HP (11-55 kW)

Standard shaft seal	Motor size [HP (kW)]	Description	Liquid temperature [°F (°C)]
HQQE		O-ring (cartridge) (balanced seal), Silicon carbide/Silicon carbide, EPDM	-40 - +248 (-40 - +120)
HQQV	15-75 (11-55)	O-ring (cartridge) (balanced seal), Silicon carbide/Silicon carbide, FKM	-4 - +194 (-20 - +90)
HQBE		O-ring (cartridge) (balanced seal), Silicon carbide/carbon, EPDM	32 - +248 (0 - +120)
HQBV		O-ring (cartridge) (balanced seal), Silicon carbide/carbon, FKM	32 - +194 (0 - +90)

Ø28 and Ø36 shaft seals for 100-300 HP (75-224 kW)

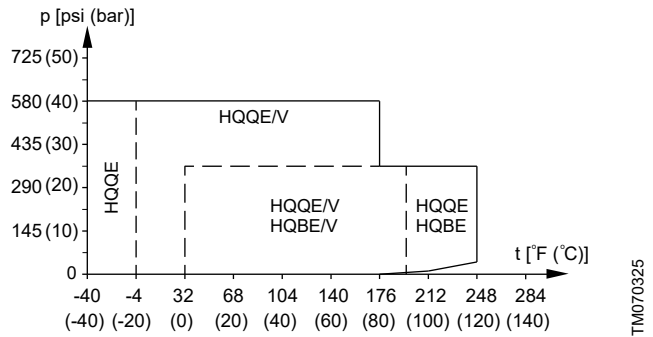

Operating range of standard shaft seals for Ø28 and Ø36 for CR 125-255, 100-300 HP (75-224 kW)

Standard shaft seal	Motor size [HP (kW)]	Description	Liquid temperature [°F (°C)]
HQQE		O-ring (cartridge) (balanced seal), Silicon carbide/Silicon carbide, EPDM	-40 - +248 (-40 - +120)
HQQV	100-300 (75-224)	O-ring (cartridge) (balanced seal), Silicon carbide/Silicon carbide, FKM	-4 - +194 (-20 - +90)
HQBE		O-ring (cartridge) (balanced seal), Silicon carbide/carbon, EPDM	32 - +248 (0 - +120)
HQBV		O-ring (cartridge) (balanced seal), Silicon carbide/carbon, FKM	32 - +194 (0 - +90)

Maximum inlet pressure

The following table shows the maximum permissible inlet pressure when the pump is at rest, vertically mounted, and fitted with a standard NEMA 60 Hz motor. Contact Grundfos to determine the maximum inlet pressure under operating conditions or pumps operating at lower rpm with additional stages.

The actual inlet pressure plus the pressure against a closed valve must always be lower than the maximum permissible operating pressure. If the maximum permissible operating pressure is exceeded, the angular contact bearing in the motor may be damaged and the life of the shaft seal reduced.

Pump type	Maximum inlet pressure [psi (bar)]
CR, CRN 95	
CR, CRN 95-1-1 → 95-2-2	145 (10)
CR, CRN 95-2-1 → 95-4-1	218 (15)
CR, CRN 95-4 → 95-5-1	290 (20)
CRN 95-6-3 → 95-8	290 (20)
CR, CRN 125	
CR, CRN 125-1-1 → 125-1	145 (10)
CR, CRN 125-2-2 → 125-3-2	218 (15)
CR, CRN 125-3-1 → 125-4-2	290 (20)
CRN 125-4-1 → 125-9-3	290 (20)
CR, CRN 155	
CR, CRN 155-1-1	145 (10)
CR, CRN 155-1 → 155-2-1	218 (15)
CR, CRN 155-2 → 155-3-2	290 (20)
CRN 155-3-1 → 155-8-3	290 (20)
CR, CRN 185	
CR, CRN 185-1-1 → 185-1	218 (15)
CR, CRN 185-2-2 → 185-6	290 (20)
CR, CRN 215	
CR, CRN 215-1-1	218 (15)
CR, CRN 215-1 → 215-5-1	290 (20)
CR, CRN 255	
CR, CRN 255-1-1	218 (15)
CR, CRN 255-1 → 255-4-1	290 (20)

Examples of operating and inlet pressures

The values for operating and inlet pressures shown in the table must not be considered individually and must comply with the below statement.

The outlet pressure must be equal to or lower than the maximum operating pressure.

See the following definitions and examples.

Definitions

Pressure type	Definition
Maximum operating pressure	The maximum pressure is stated on the nameplate.
Pump differential pressure	The difference between the outlet pressure and inlet pressure.
Inlet pressure	The pressure measured at the pump inlet.
Outlet pressure	The inlet pressure added to the pump differential pressure.

Example

The following pump type has been selected: CR 95-3.

Maximum operating pressure: 363 psi (25 bar).

Maximum inlet pressure: 218 psi (15 bar).

Pump differential pressure when operating against a closed outlet valve (flow = 0 GPM (0 m³/h)):

436 ft head = 190 psi (133 m head = 13.07 bar).

See performance curves and technical data.

This pump is not allowed to start at an inlet pressure of 218 psi (15 bar). Start this pump at an inlet pressure of 363 - 190 = 173 psi (25 - 13.07 = 11.93 bar).

7. Selection and sizing

Selection of pump

Base the selection of pump on these parameters:

- Duty point of the pump. See section about duty point.
- Sizing data such as pressure loss as a result of height differences, friction loss in the pipes, pump efficiency. See section about sizing data.
- Pump materials. See section about pump material.
- Pump connections. See section about pump connections.
- Shaft seal. See section about shaft seal.

Sizing data

When sizing a pump, take these parameters into account:

- Required flow rate and pressure at the draw-off point.
- Pressure loss as a result of height differences (H_{geo}).
- Friction loss in the pipes (H_f). It may be necessary to account for pressure loss in connection with long pipes, bends, valves, and similar.
- Best efficiency at the estimated duty point.
- NPSH value. For calculation of the NPSH value, see section about minimum inlet pressure, NPSH.

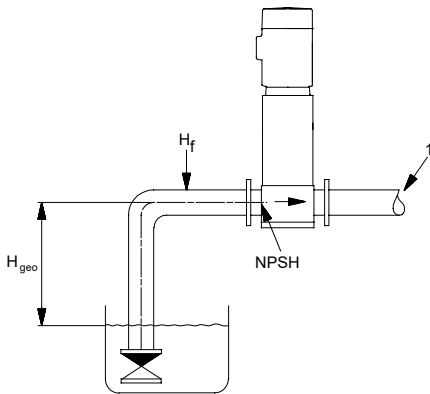

Sizing data

Pos.	Description
1	Required flow rate, required pressure

Pump efficiency

Before determining the best efficiency point, identify the operation pattern of the pump. If the pump is expected to always operate at the same duty point, select a pump which is operating at a duty point corresponding to the best efficiency of the pump.

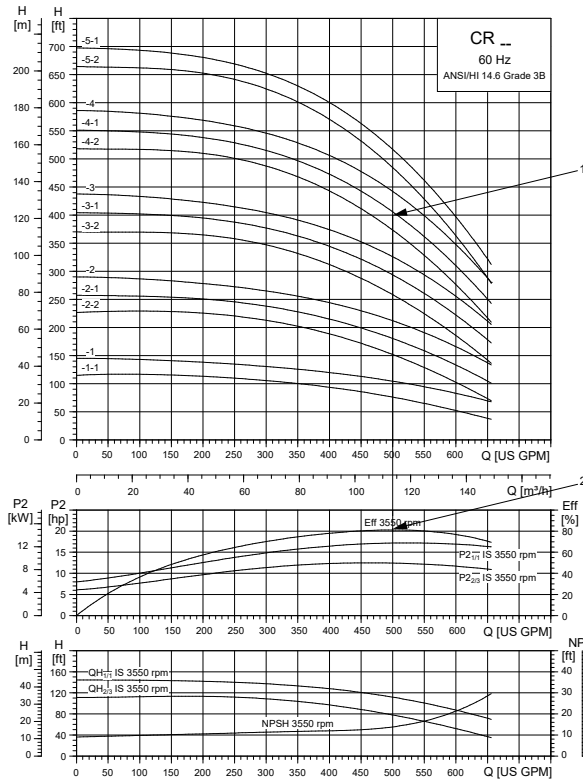

Example of a CR pump's duty point

Pos.	Description
1	Duty point
2	Best efficiency

As the pump is sized on the basis of the highest possible flow rate, it is important to always have the duty point to the right of the best efficiency point on the efficiency curve (Eff). This must be considered in order to keep the efficiency high when the flow rate drops.

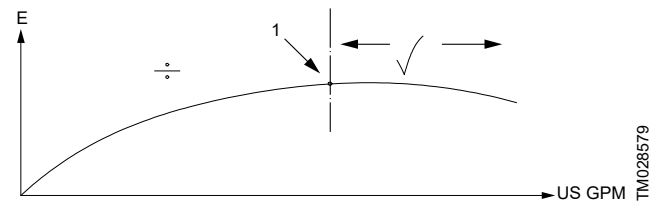

Best efficiency

Pos.	Description
1	Best efficiency point

TM026711

TM079033

TM028579

Pump material

Select the material variant on the basis of the liquid to be pumped.

The product range covers the following basic types.

- CR, CRI: Use CR, CRI pumps for clean, non-aggressive liquids, such as potable water and oils.
- CRN: Use CRN pumps for industrial liquids and acids. See section about list of pumped liquids, or contact Grundfos.

For saline or chloride-containing liquids, such as sea water, CRT pumps of titanium are available.

Duty point of the pump

From a duty point, you can select a pump on the basis of performance curve charts. Ideally, the duty point should match the best efficiency point on the pump curve.

Pump connection

Selection of pump connection depends on the rated pressure and the pipes. To meet any requirement, the CR, CRN pumps offer a wide range of flexible connections, such as:

- ANSI flange
- DIN flange
- PJE coupling (Victaulic type)
- other connections on request.

Shaft seal



Shaft seal (cartridge type)

As standard, the CR range is fitted with a Grundfos shaft seal (cartridge type) suitable for the most common applications.

The following key parameters must be taken into account when selecting the shaft seal:

- type of pumped liquid
- liquid temperature
- maximum pressure.

Grundfos offers a wide range of shaft seal variants to meet specific demands according to the pumped liquids.

Servicing shaft seals

Replacement shaft seals are available as complete service kits.

Shaft seals fitted on CR, CRN 95-185 pumps with $\varnothing 28$ mm or $\varnothing 36$ mm shaft ends are serviceable. This means that the wear parts in these shaft seals are available as service kits and can be replaced without having to renew the complete shaft seal.

All service kits include detailed instructions on how to carry out the replacement.

Thrust handling device

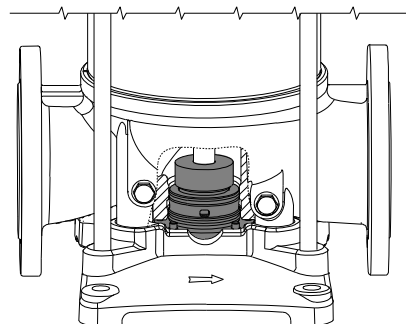

TM069669

Thrust handling device

A thrust handling device (THD) is factory-fitted on pumps with 100 HP (75 kW) motors or larger. The system consists of two parts. A rotating part mounted on the shaft end below the first impeller as well as a non-rotating part mounted in or on the pump base.

The THD absorbs the main part of the thrust force generated by the impellers and thereby reduces the resulting axial force the motor bearings must absorb. This enables the use of standard ball bearings in the motor instead of special angular contact ball bearings.

Note: For applications involving CIP (clean-in-place) and motors above 75 HP (55 kW), use a bearing flange and a base without THD.

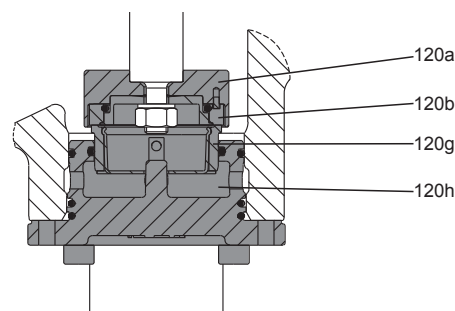

TM069670

Position numbers for THD parts

Pos.	Description	Material
120a	Thrust disc	Stainless steel
120b	Rotating ring	Silicon carbide
120g	Stationary ring	Silicon carbide ¹⁴⁾ Tungsten carbide
120h	Lifting plate	Stainless steel
-	O-rings	EPDM/FKM

¹⁴⁾ On request for CRN.

Operating pressure and inlet pressure

Do not exceed the limit values for these pressures:

- maximum operating pressure
- maximum inlet pressure.

Grundfos Product Center

We recommend that you size your pump in Grundfos Product Center, which is a selection program offered by Grundfos. Grundfos Product Center features a user-friendly and easy-to-use virtual guide which leads you through the selection of the pump for the application in question. See section about Grundfos Product Center.

Related information

Pumped liquids

Minimum inlet pressure, NPSH

11. Grundfos Product Center

Minimum inlet pressure, NPSH

We recommend that you calculate the inlet pressure "H" in these situations:

- The liquid temperature is high.
- The flow rate is significantly higher than the rated flow rate.
- Water is drawn from depths.
- Water is drawn through long pipes.
- Inlet conditions are poor.

To avoid cavitation, make sure that there is a minimum pressure on the inlet side of the pump.

Calculate the maximum suction lift "H" in feet of head as follows:

H	=	$p_b \times 2.31 - NPSH - H_f - H_v$
p _b	=	Barometric pressure in psi. P _b can be set to 14.7 psi at sea level. In closed systems, p _b indicates the system pressure in psi.
NPSH	=	Net Positive Suction Head in feet of head. To be read from the NPSH curve at the highest flow the pump will be delivering.
H _f	=	Friction loss in inlet pipe in feet of head at the highest flow the pump will be delivering.
H _v	=	Vapor pressure in feet of head. To be read from the vapor pressure scale. H _v depends on the liquid temperature t _m .

If the calculated "H" is positive, the pump can operate at a suction lift of maximum "H" feet of head.

If the calculated "H" is negative, an inlet pressure of minimum "H" feet of head is required.

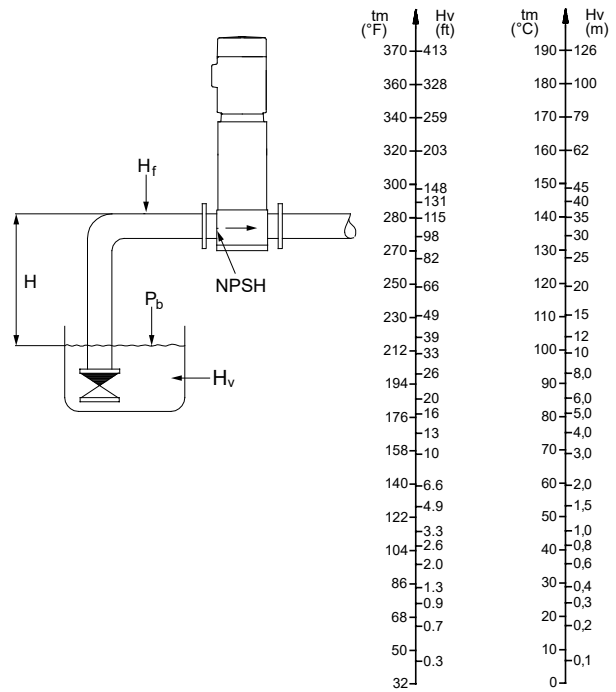

Minimum inlet pressure, NPSH

To avoid cavitation, never select a pump with a duty point too far to the right on the NPSH curve.

Always check the NPSH value of the pump at the highest possible flow rate.

TM079036

How to read the curve charts

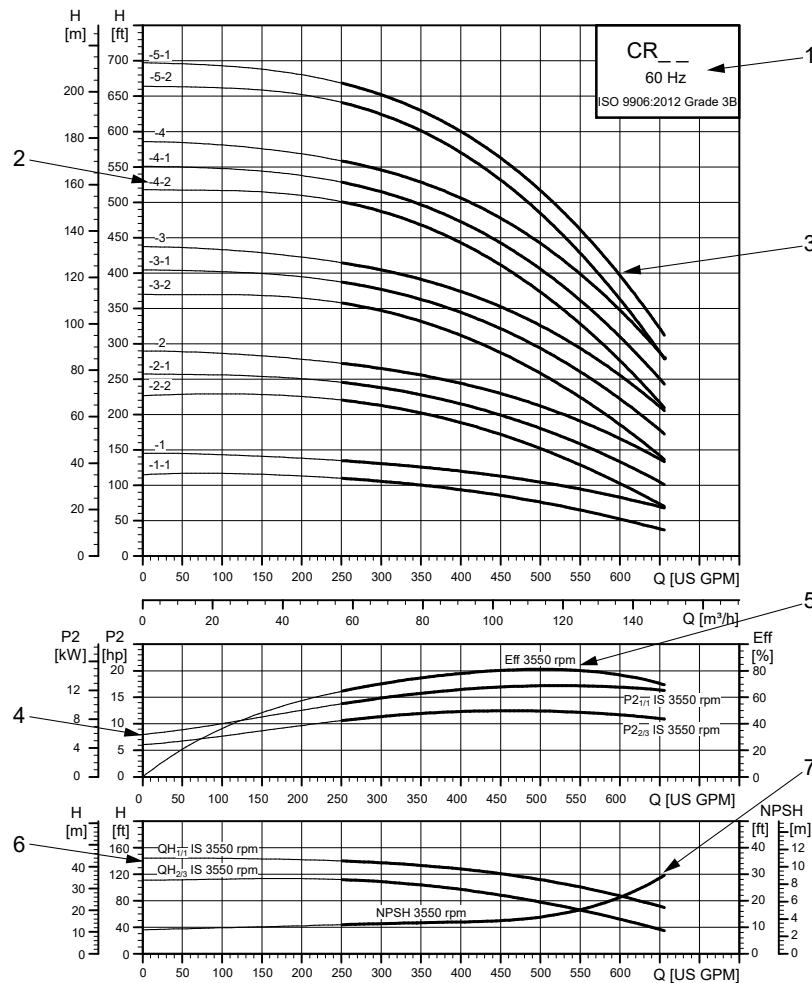

TM079034

Pos.	Description
1	Pump type. Frequency, poles or speed. ISO or ANSI standard.
2	Number of stages. First figure: number of stages. Second figure: number of reduced-diameter impellers.
3	QH curve of the individual pump. The bold curves indicate the recommended duty range for best efficiency.
4	The power curves indicate pump input power per stage . Curves are shown for full (1/1) and for reduced-diameter (2/3) impellers.
5	The Eff curve shows the efficiency of a pump with three full size impellers. The efficiency of pumps with reduced-diameter impellers is approximately 2 % lower than the Eff curve shown in the chart.
6	QH curve for each individual impeller. Curves are shown for full (1/1) and for reduced-diameter (2/3) impellers.
7	The NPSH curve is a maximum curve for all the variants shown.

Guidelines to performance curves

The guidelines below apply to the performance curves:

- Tolerances to ANSI or ISO standards, such as ISO 9906:2012, Grade 3B, if indicated on the curve chart.
- The motors used for the measurements are standard Grundfos-specified motors.
- Measurements have been made with airless water at a temperature of 68 °F (20 °C).
- The curves apply to the following kinematic viscosity: $\nu = 1 \text{ mm}^2/\text{s}$ (1 cSt).
- Due to the risk of overheating, the pumps must not be used at a flow rate below the minimum flow rate.
- The QH curves apply to a rated motor speed of a three-phase mains-operated motor. For realistic curves, go to Grundfos Product Center (<http://product-selection.grundfos.com>), and insert data.

The curve below shows the minimum flow rate as a percentage of the rated flow rate in relation to the liquid temperature. The dotted line shows a CR pump fitted with an air-cooled top assembly.

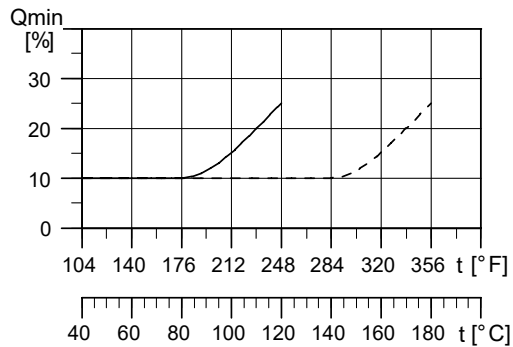

TM027538

Minimum flow rate

8. Performance curves and technical data

CR 95

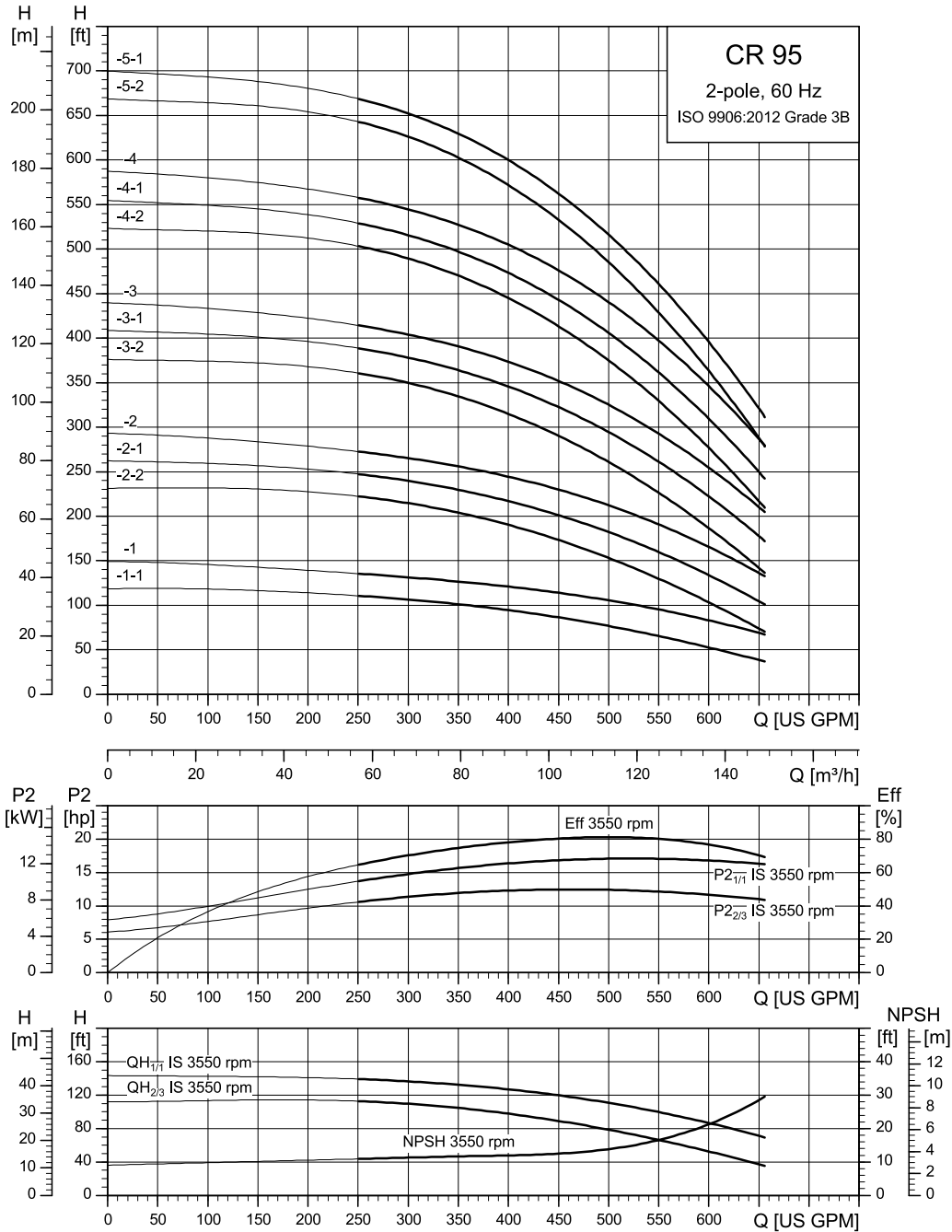

The maximum pump efficiency (Eff) is based on a three-stage pump.

TM065537

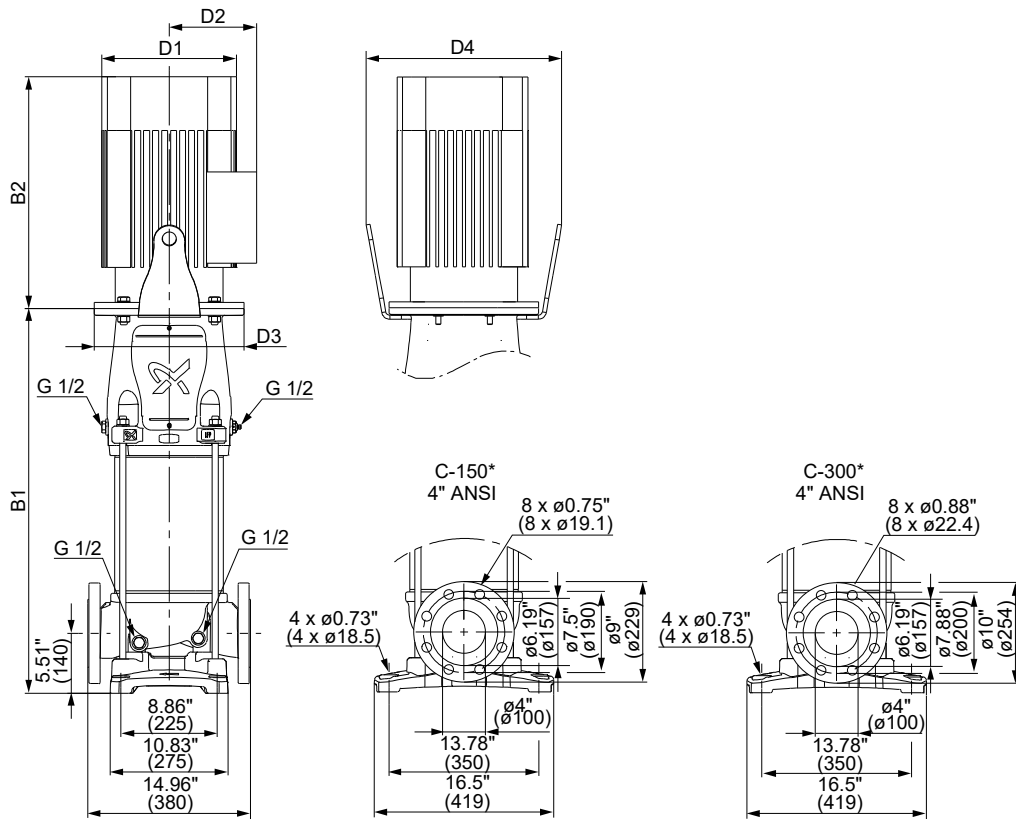

TM066059

* C-150: CR 95 pumps with up to four stages (with one reduced-diameter impeller) are fitted with class 150 flanges as standard. Class 300 flanges are available on request.

* C-300: CR 95 pumps with four or more stages are fitted with class 300 flanges as standard.

Dimensions and weights

Pump type	Motor [HP]	Dimensions [inch (mm)]						Net weight [lbs (kg)]
		B1	B1+B2	D1	D2	D3	D4	
CR 95-1-1	15	27.4 (696)	46.2 (1174)	13.2 (335)	9.4 (240)	15.7 (400)	19.4 (492)	439 (199)
CR 95-1	20	27.4 (696)	47.0 (1194)	13.2 (335)	9.4 (240)	15.7 (400)	19.4 (492)	479 (217)
CR 95-2-2	25	31.5 (800)	55.1 (1399)	14.2 (360)	11.1 (282)	15.7 (400)	20.9 (532)	661 (300)
CR 95-2-1	30	31.5 (800)	55.1 (1399)	14.2 (360)	11.1 (282)	15.7 (400)	20.9 (532)	669 (303)
CR 95-2	30	31.5 (800)	55.1 (1399)	14.2 (360)	11.1 (282)	15.7 (400)	20.9 (532)	669 (303)
CR 95-3-2	40	36.4 (925)	62.5 (1588)	15.8 (402)	12.6 (320)	17.7 (450)	22.6 (573)	825 (374)
CR 95-3-1	50	36.4 (925)	62.5 (1588)	15.8 (402)	12.6 (320)	17.7 (450)	22.6 (573)	859 (390)
CR 95-3	50	36.4 (925)	62.5 (1588)	15.8 (402)	12.6 (320)	17.7 (450)	22.6 (573)	859 (390)
CR 95-4-2	60	40.5 (1029)	69.3 (1761)	17.9 (455)	16.0 (407)	17.7 (450)	24.2 (614)	1172 (532)
CR 95-4-1	60	40.5 (1029)	69.3 (1761)	17.9 (455)	16.0 (407)	17.7 (450)	24.2 (614)	1172 (532)
CR 95-4	75	40.5 (1029)	69.3 (1761)	17.9 (455)	16.0 (407)	17.7 (450)	24.2 (614)	1186 (538)
CR 95-5-2	75	44.6 (1134)	73.5 (1866)	17.9 (455)	16.0 (407)	17.7 (450)	24.2 (614)	1200 (544)
CR 95-5-1	75	44.6 (1134)	73.5 (1866)	17.9 (455)	16.0 (407)	17.7 (450)	24.2 (614)	1200 (544)

CRN 95

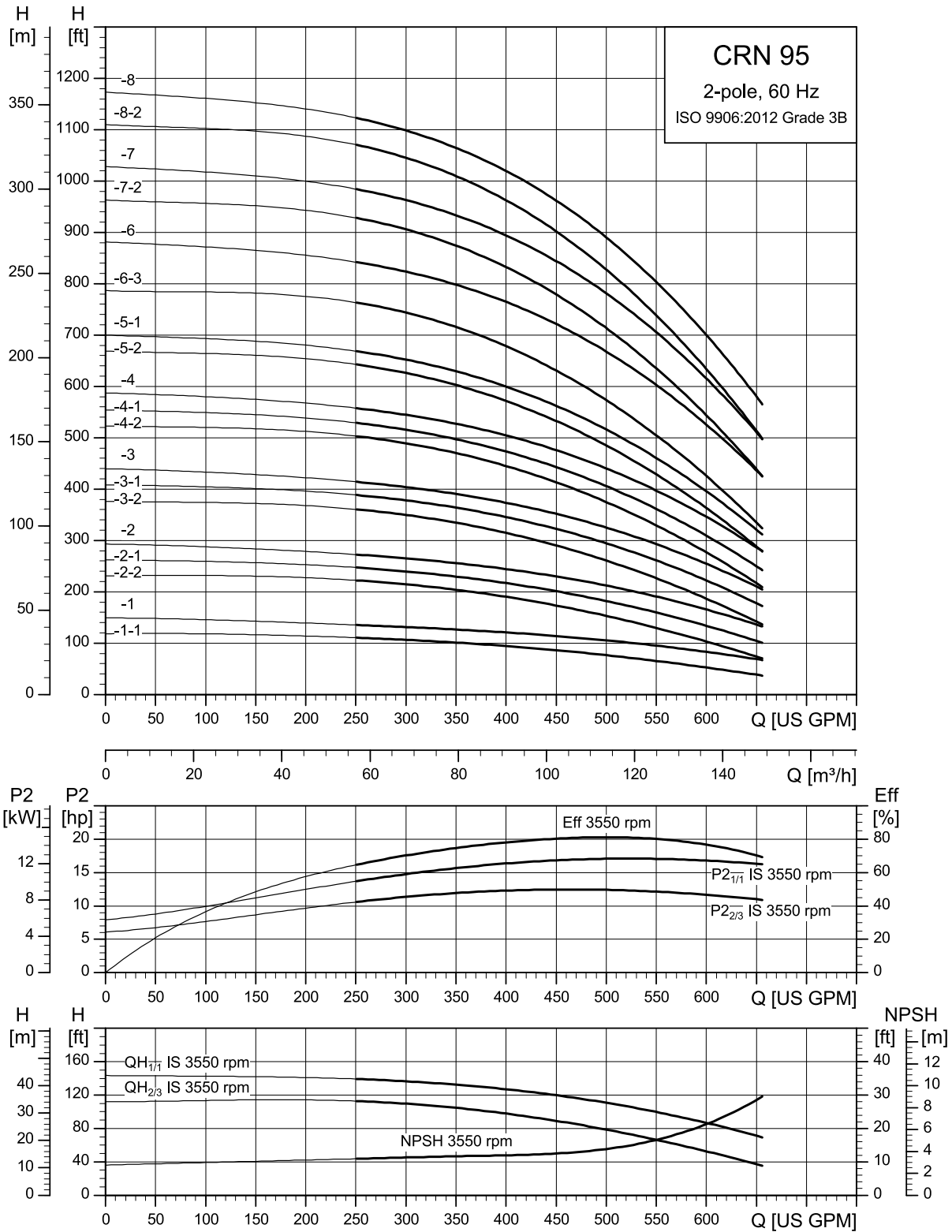

TM065538

The maximum pump efficiency (Eff) is based on a three-stage pump.

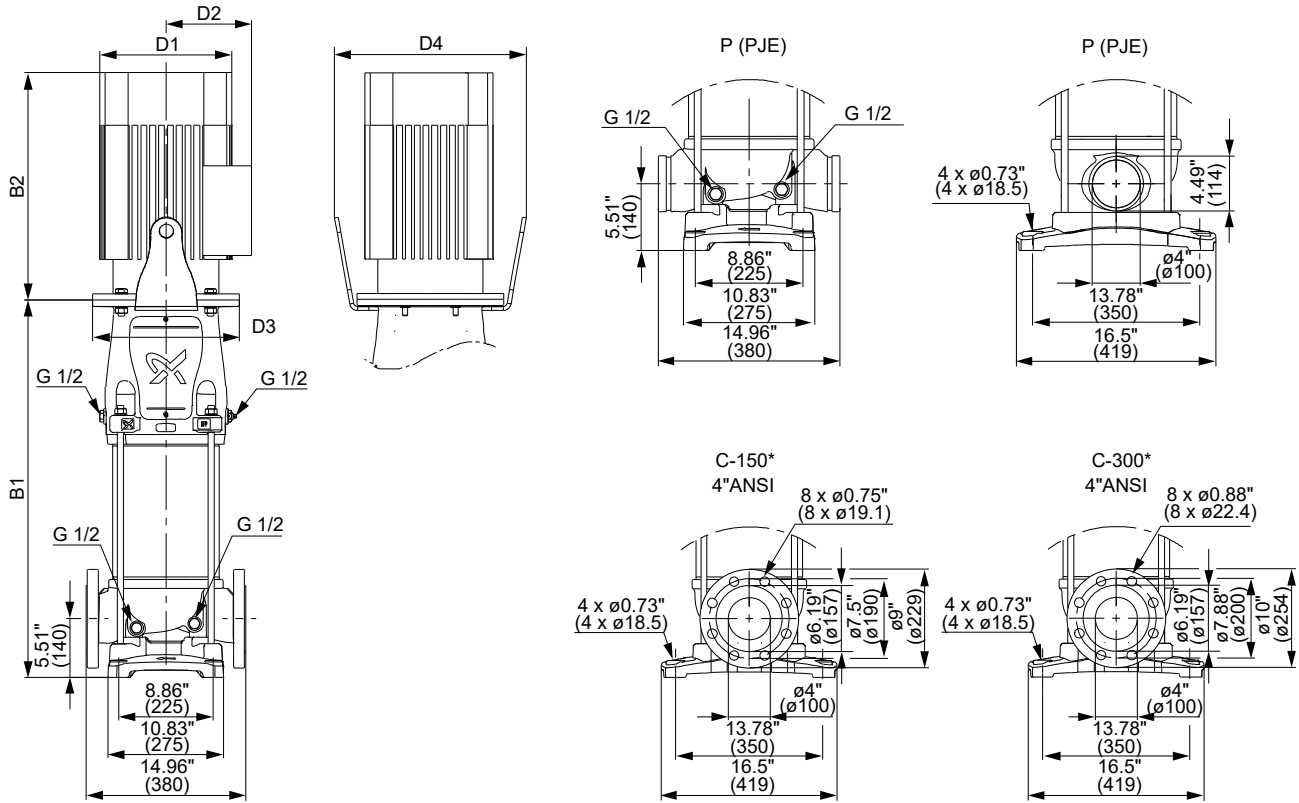

TM066060

* C-150: CRN 95 pumps with one to four stages (with one reduced-diameter impeller) are fitted with class 150 flanges as standard. Class 300 flanges are available on request.

* C-300: CRN 95 pumps with four or more stages are fitted with class 300 flanges as standard.

Dimensions and weights

Pump type	Motor [HP]	Dimensions [inch (mm)]						Net weight [lbs (kg)]
		B1	B1+B2	D1	D2	D3	D4	
CRN 95-1-1	15	27.4 (696)	46.2 (1174)	13.2 (335)	9.4 (240)	15.7 (400)	19.4 (492)	439 (199)
CRN 95-1	20	27.4 (696)	47.0 (1194)	13.2 (335)	9.4 (240)	15.7 (400)	19.4 (492)	479 (217)
CRN 95-2-2	25	31.5 (800)	55.1 (1399)	14.2 (360)	11.1 (282)	15.7 (400)	20.9 (532)	661 (300)
CRN 95-2-1	30	31.5 (800)	55.1 (1399)	14.2 (360)	11.1 (282)	15.7 (400)	20.9 (532)	669 (303)
CRN 95-2	30	31.5 (800)	55.1 (1399)	14.2 (360)	11.1 (282)	15.7 (400)	20.9 (532)	669 (303)
CRN 95-3-2	40	36.4 (925)	62.5 (1588)	15.8 (402)	12.6 (320)	17.7 (450)	22.6 (573)	825 (374)
CRN 95-3-1	50	36.4 (925)	62.5 (1588)	15.8 (402)	12.6 (320)	17.7 (450)	22.6 (573)	859 (390)
CRN 95-3	50	36.4 (925)	62.5 (1588)	15.8 (402)	12.6 (320)	17.7 (450)	22.6 (573)	859 (390)
CRN 95-4-2	60	40.5 (1029)	69.3 (1761)	17.9 (455)	16.0 (407)	17.7 (450)	24.2 (614)	1172 (532)
CRN 95-4-1	60	40.5 (1029)	69.3 (1761)	17.9 (455)	16.0 (407)	17.7 (450)	24.2 (614)	1172 (532)
CRN 95-4	75	40.5 (1029)	69.3 (1761)	17.9 (455)	16.0 (407)	17.7 (450)	24.2 (614)	1186 (538)
CRN 95-5-2	75	44.6 (1134)	73.5 (1866)	17.9 (455)	16.0 (407)	17.7 (450)	24.2 (614)	1200 (544)
CRN 95-5-1	75	44.6 (1134)	73.5 (1866)	17.9 (455)	16.0 (407)	17.7 (450)	24.2 (614)	1200 (544)
CRN 95-6-3 ¹⁵⁾	100	48.7 (1237)	81.2 (2062)	19.1 (486)	16.0 (407)	21.7 (550)	36.1 (918)	1569 (712)
CRN 95-6 ¹⁵⁾	100	48.7 (1237)	81.2 (2062)	19.1 (486)	16.0 (407)	21.7 (550)	36.1 (918)	1569 (712)
CRN 95-7-2 ¹⁵⁾	100	52.8 (1342)	85.3 (2167)	19.1 (486)	16.0 (407)	21.7 (550)	36.1 (918)	1582 (718)
CRN 95-7 ¹⁵⁾	125	52.8 (1342)	89.5 (2273)	23.6 (599)	18.6 (472)	21.7 (550)	36.1 (918)	2129 (966)
CRN 95-8-2 ¹⁵⁾	125	56.9 (1446)	93.6 (2377)	23.6 (599)	18.6 (472)	21.7 (550)	36.1 (918)	2142 (972)
CRN 95-8 ¹⁵⁾	125	56.9 (1446)	93.6 (2377)	23.6 (599)	18.6 (472)	21.7 (550)	36.1 (918)	2142 (972)

¹⁵⁾ Only to be used with soft starter or frequency converter.

CR 125

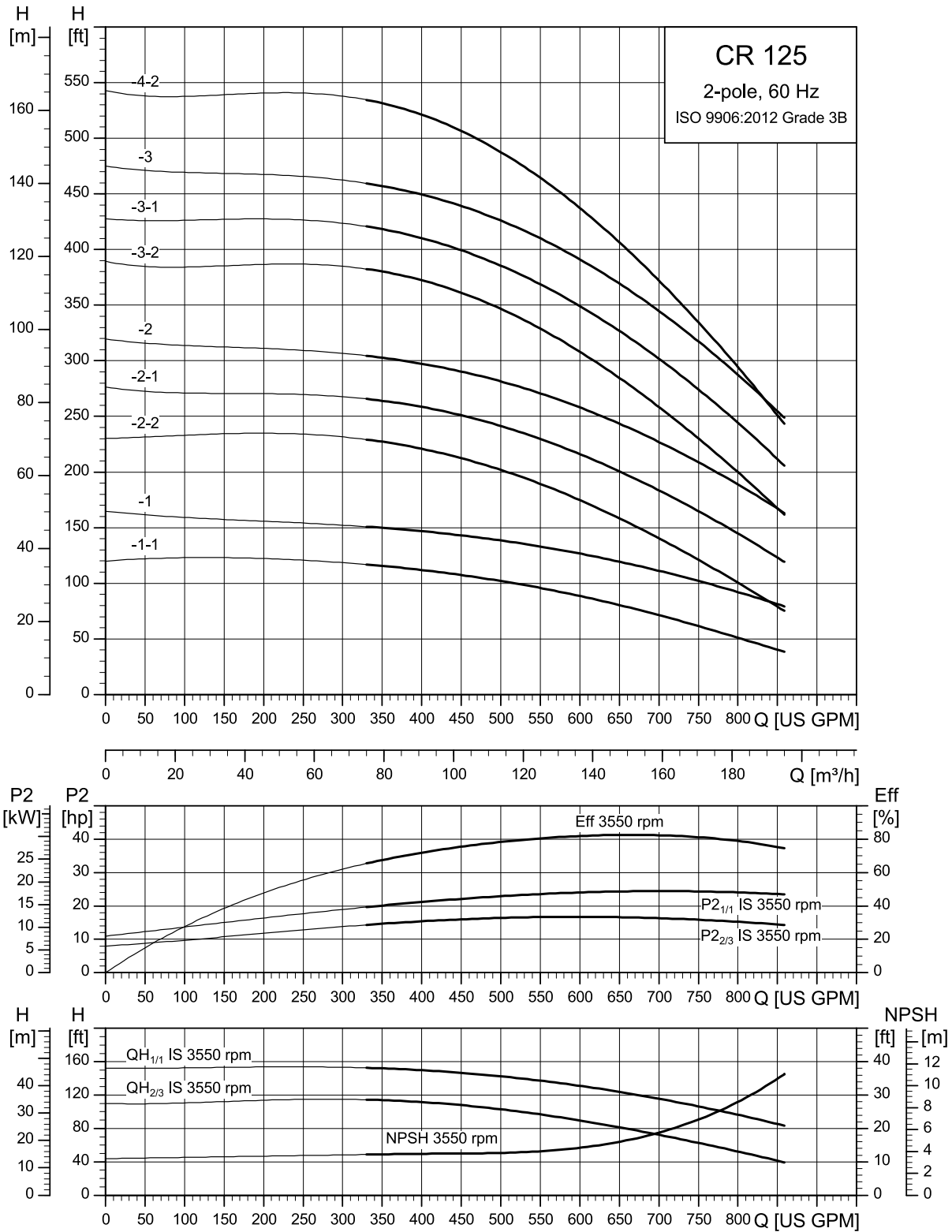

The maximum pump efficiency (Eff) is based on a three-stage pump.

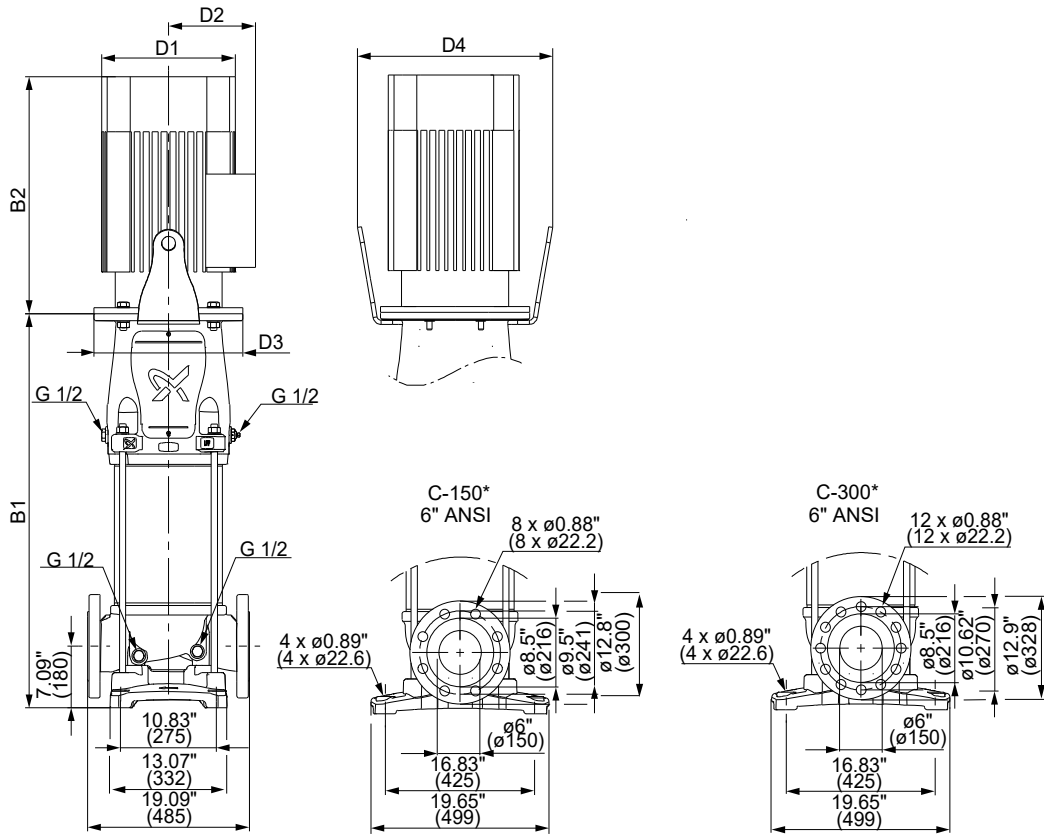

TM066061

* C-150: CR 125 pumps with up to three stages are fitted with class 150 flanges as standard. Class 300 flanges are available on request.

* C-300: CR 125 pumps with four or more stages are fitted with class 300 flanges as standard.

Dimensions and weights

Pump type	Motor [HP]	Dimensions [inch (mm)]						Net weight [lbs (kg)]
		B1	B1+B2	D1	D2	D3	D4	
CR 125-1-1	20	30.8 (783)	50.4 (1281)	13.2 (335)	9.4 (240)	13.8 (350)	17.4 (442)	557 (253)
CR 125-1	25	30.9 (785)	54.5 (1384)	14.2 (360)	11.1 (282)	15.7 (400)	19.4 (492)	736 (334)
CR 125-2-2	30	35.7 (907)	59.3 (1506)	14.2 (360)	11.1 (282)	15.7 (400)	19.4 (492)	767 (348)
CR 125-2-1	40	36.6 (930)	62.7 (1593)	15.8 (402)	12.6 (320)	17.7 (450)	22.6 (573)	916 (416)
CR 125-2	50	36.6 (930)	62.7 (1593)	15.8 (402)	12.6 (320)	17.7 (450)	22.6 (573)	950 (431)
CR 125-3-2	60	41.4 (1052)	70.2 (1784)	17.9 (455)	16.0 (407)	17.7 (450)	22.6 (573)	1262 (573)
CR 125-3-1	75	41.4 (1052)	70.2 (1784)	17.9 (455)	16.0 (407)	17.7 (450)	22.6 (573)	1266 (574)
CR 125-3	75	41.4 (1052)	70.2 (1784)	17.9 (455)	16.0 (407)	17.7 (450)	22.6 (573)	1266 (574)
CR 125-4-2	75	46.2 (1174)	75.0 (1906)	17.9 (455)	16.0 (407)	17.7 (450)	22.6 (573)	1317 (597)

CRN 125

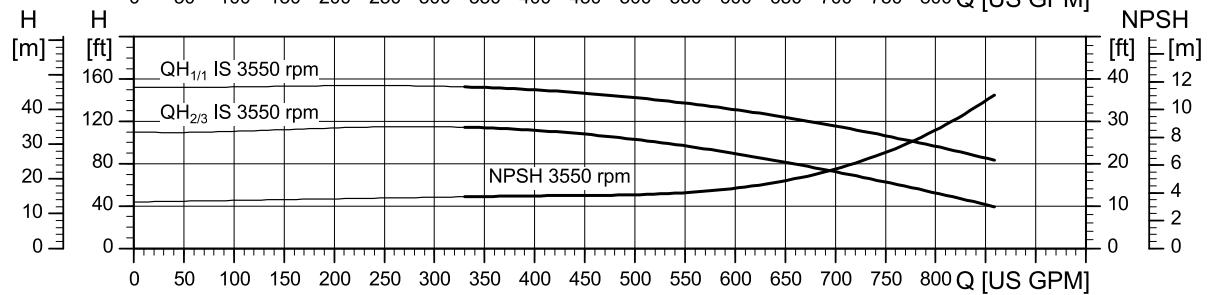
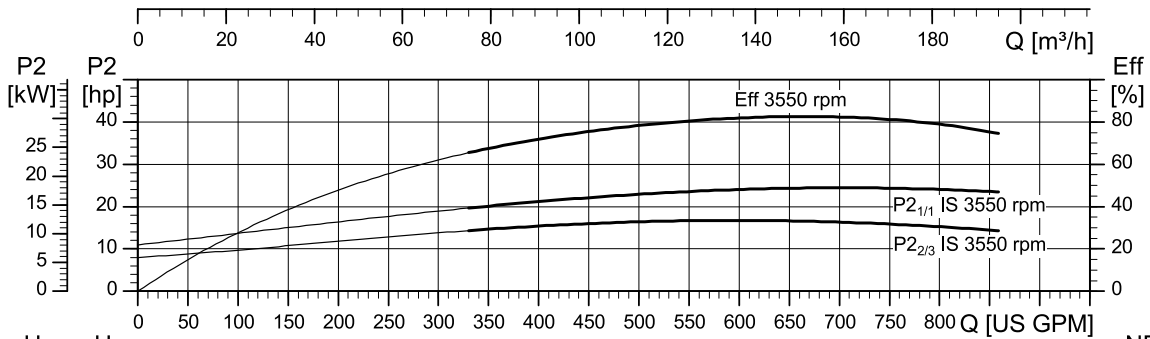
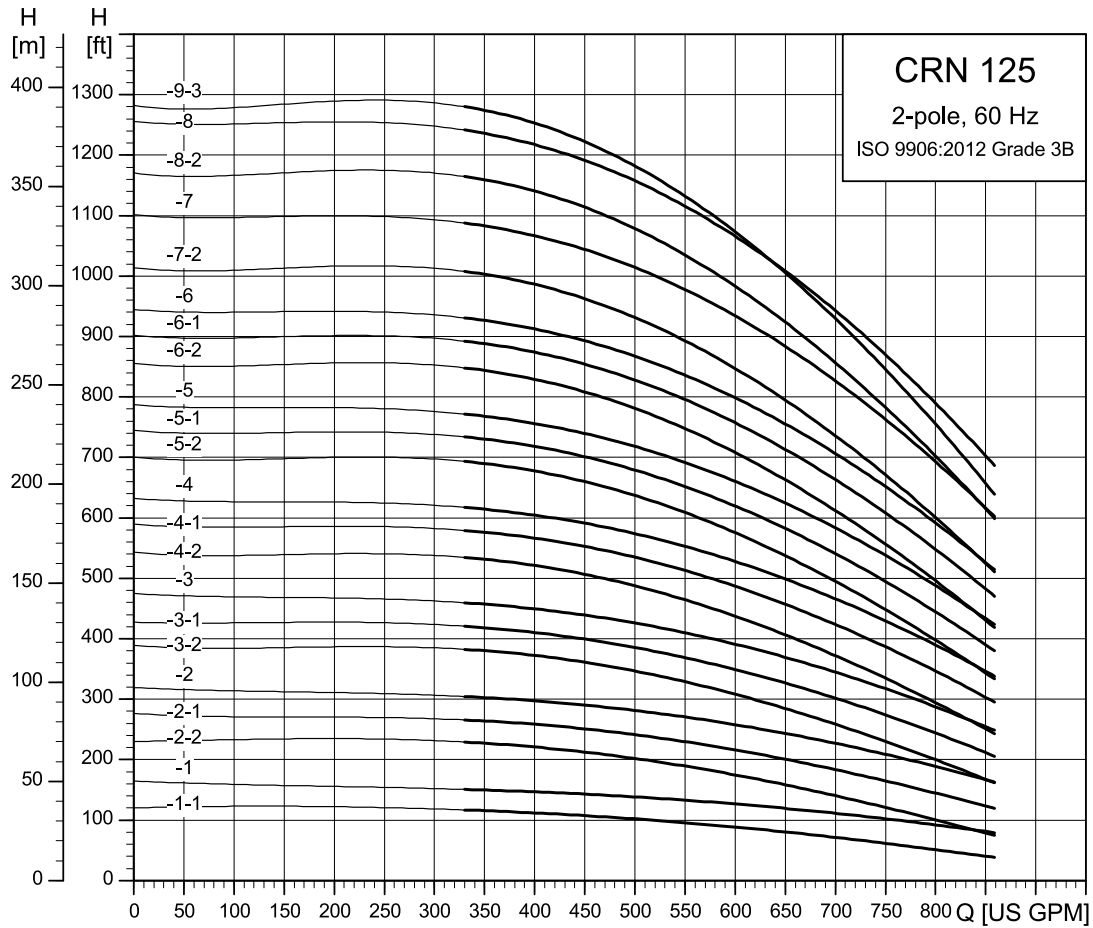

The maximum pump efficiency (Eff) is based on a three-stage pump.

TM065540

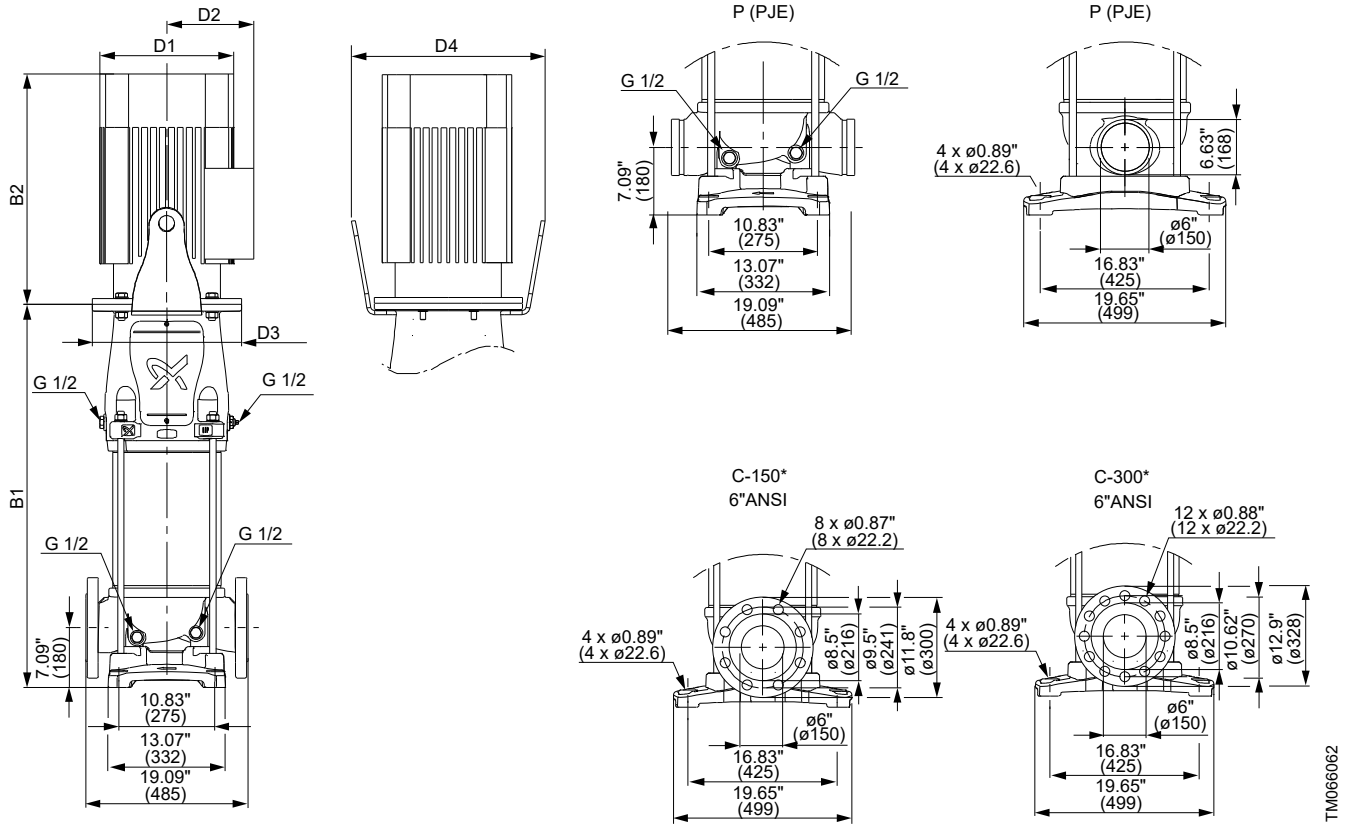

TM066062

* C-150: CRN 125 pumps with up to three stages are fitted with class 150 flanges as standard. Class 300 flanges are available on request.

* C-300: CRN 125 pumps with four or more stages are fitted with class 300 flanges as standard.

Dimensions and weights

Pump type	Motor [HP]	Dimensions [inch (mm)]						Net weight [lbs (kg)]
		B1	B1+B2	D1	D2	D3	D4	
CRN 125-1-1	20	30.8 (783)	50.4 (1281)	13.2 (335)	9.4 (240)	13.8 (350)	17.4 (442)	557 (253)
CRN 125-1	25	30.9 (785)	54.5 (1384)	14.2 (360)	11.1 (282)	15.7 (400)	19.4 (492)	736 (334)
CRN 125-2-2	30	35.7 (907)	59.3 (1506)	14.2 (360)	11.1 (282)	15.7 (400)	19.4 (492)	767 (348)
CRN 125-2-1	40	36.6 (930)	62.7 (1593)	15.8 (402)	12.6 (320)	17.7 (450)	22.6 (573)	916 (416)
CRN 125-2	50	36.6 (930)	62.7 (1593)	15.8 (402)	12.6 (320)	17.7 (450)	22.6 (573)	950 (431)
CRN 125-3-2	60	41.4 (1052)	70.2 (1784)	17.9 (455)	16.0 (407)	17.7 (450)	22.6 (573)	1262 (573)
CRN 125-3-1	75	41.4 (1052)	70.2 (1784)	17.9 (455)	16.0 (407)	17.7 (450)	22.6 (573)	1266 (574)
CRN 125-3	75	41.4 (1052)	70.2 (1784)	17.9 (455)	16.0 (407)	17.7 (450)	22.6 (573)	1266 (574)
CRN 125-4-2	75	46.2 (1174)	75.0 (1906)	17.9 (455)	16.0 (407)	17.7 (450)	22.6 (573)	1317 (597)
CRN 125-4-1	100	46.2 (1173)	78.7 (1998)	19.1 (486)	16.0 (407)	21.7 (550)	36.1 (918)	1691 (767)
CRN 125-4	100	46.2 (1173)	78.7 (1998)	19.1 (486)	16.0 (407)	21.7 (550)	36.1 (918)	1691 (767)
CRN 125-5-2	100	51.0 (1295)	83.5 (2120)	19.1 (486)	16.0 (407)	21.7 (550)	36.1 (918)	1713 (777)
CRN 125-5-1	125	51.0 (1295)	87.6 (2226)	23.6 (599)	18.6 (472)	21.7 (550)	36.1 (918)	2248 (1020)
CRN 125-5	125	51.0 (1295)	87.6 (2226)	23.6 (599)	18.6 (472)	21.7 (550)	36.1 (918)	2248 (1020)
CRN 125-6-2	125	55.8 (1417)	92.4 (2348)	23.6 (599)	18.6 (472)	21.7 (550)	36.1 (918)	2270 (1030)
CRN 125-6-1	150	55.8 (1417)	92.4 (2348)	23.6 (599)	18.6 (472)	21.7 (550)	36.1 (918)	2384 (1082)
CRN 125-6	150	55.8 (1417)	92.4 (2348)	23.6 (599)	18.6 (472)	21.7 (550)	36.1 (918)	2384 (1082)
CRN 125-7-2	150	60.6 (1539)	97.2 (2470)	23.6 (599)	18.6 (472)	21.7 (550)	36.1 (918)	2407 (1092)

Pump type	Motor [HP]	Dimensions [inch (mm)]						Net weight [lbs (kg)]
		B1	B1+B2	D1	D2	D3	D4	
CRN 125-7 ¹⁶⁾	200	60.6 (1539)	109 (2757)	23.6 (599)	20.6 (522)	21.7 (550)	36.1 (918)	2873 (1303)
CRN 125-8-2 ¹⁶⁾	200	65.4 (1661)	113 (2879)	23.6 (599)	20.6 (522)	21.7 (550)	36.1 (918)	2895 (1313)
CRN 125-8 ¹⁶⁾	200	65.4 (1661)	113 (2879)	23.6 (599)	20.6 (522)	21.7 (550)	36.1 (918)	2895 (1313)
CRN 125-9-3 ¹⁶⁾	200	70.2 (1783)	118 (3001)	23.6 (599)	20.6 (522)	21.7 (550)	36.1 (918)	2918 (1324)

¹⁶⁾ Only to be used with soft starter or frequency converter.

CR 155

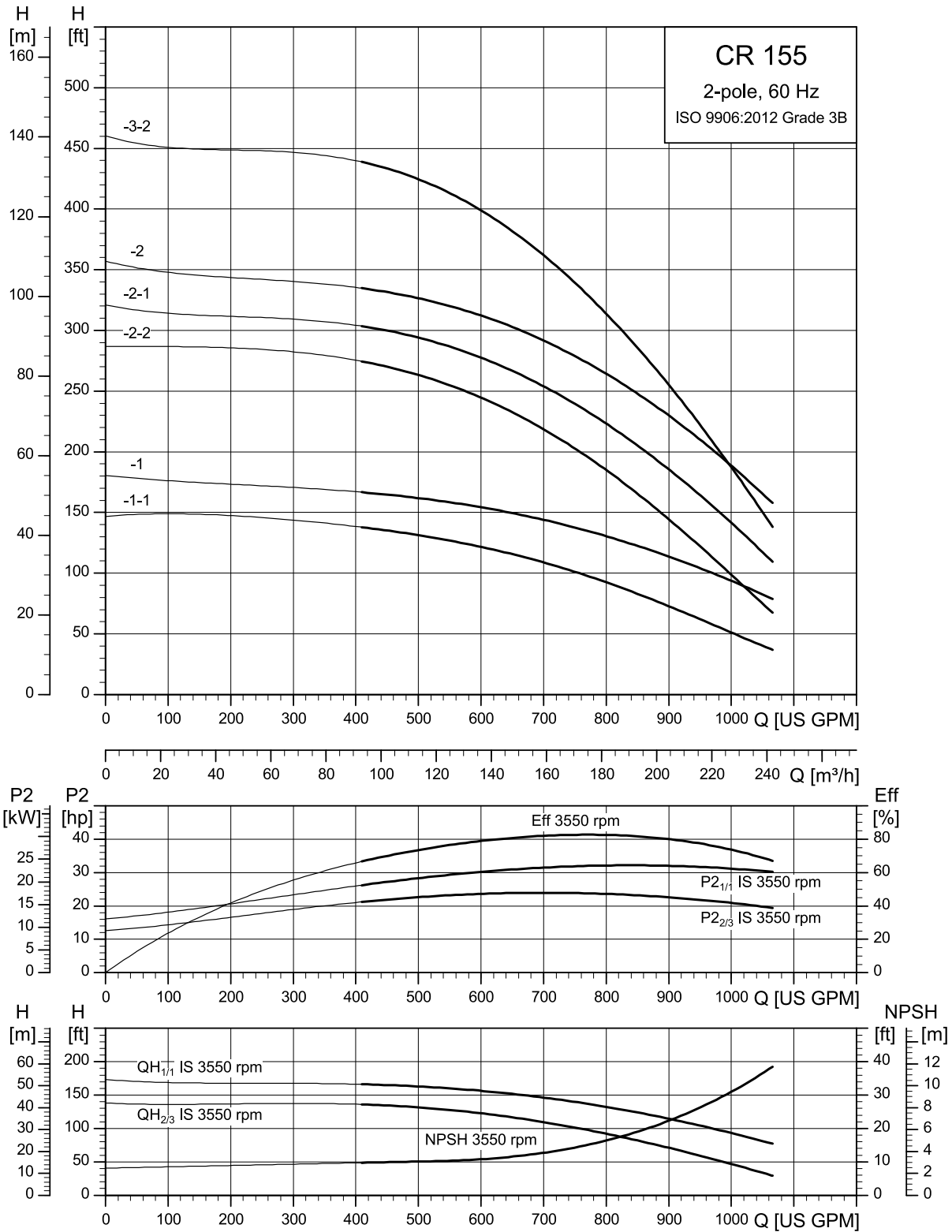

The maximum pump efficiency (Eff) is based on a three-stage pump.

TM065541

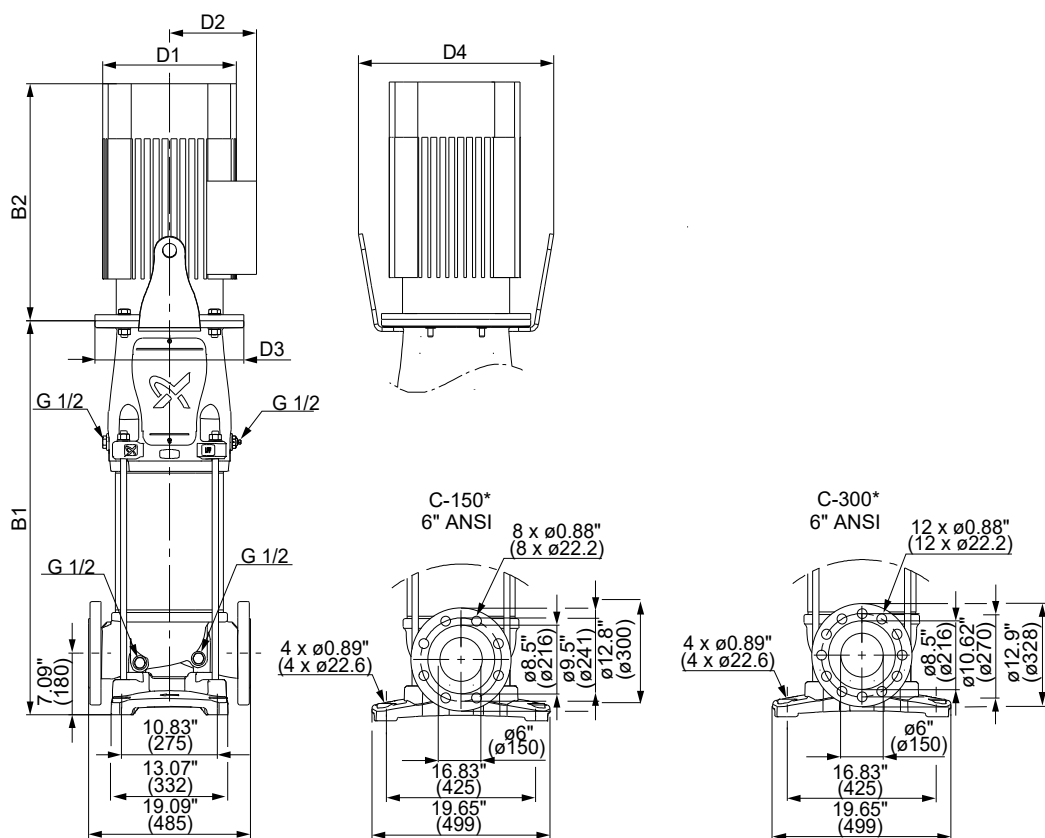

TM066061

* C-150: CR 155 pumps with up to three stages (with two reduced-diameter impellers) are fitted with class 150 flanges as standard. Class 300 flanges are available on request.

Dimensions and weights

Pump type	Motor [HP]	Dimensions [inch (mm)]						Net weight [lbs (kg)]
		B1	B1+B2	D1	D2	D3	D4	
CR 155-1-1	25	30.9 (785)	54.5 (1384)	14.2 (360)	11.1 (282)	15.7 (400)	19.4 (492)	738 (335)
CR 155-1	40	31.8 (808)	57.9 (1471)	15.8 (402)	12.6 (320)	17.7 (450)	22.6 (573)	895 (406)
CR 155-2-2	50	36.6 (930)	62.7 (1593)	15.8 (402)	12.6 (320)	17.7 (450)	22.6 (573)	952 (432)
CR 155-2-1	60	36.6 (930)	65.4 (1662)	17.9 (455)	16.0 (407)	17.7 (450)	22.6 (573)	1242 (563)
CR 155-2	75	36.6 (930)	65.4 (1662)	17.9 (455)	16.0 (407)	17.7 (450)	22.6 (573)	1245 (565)
CR 155-3-2	75	41.4 (1052)	70.2 (1784)	17.9 (455)	16.0 (407)	17.7 (450)	22.6 (573)	1269 (576)

CRN 155

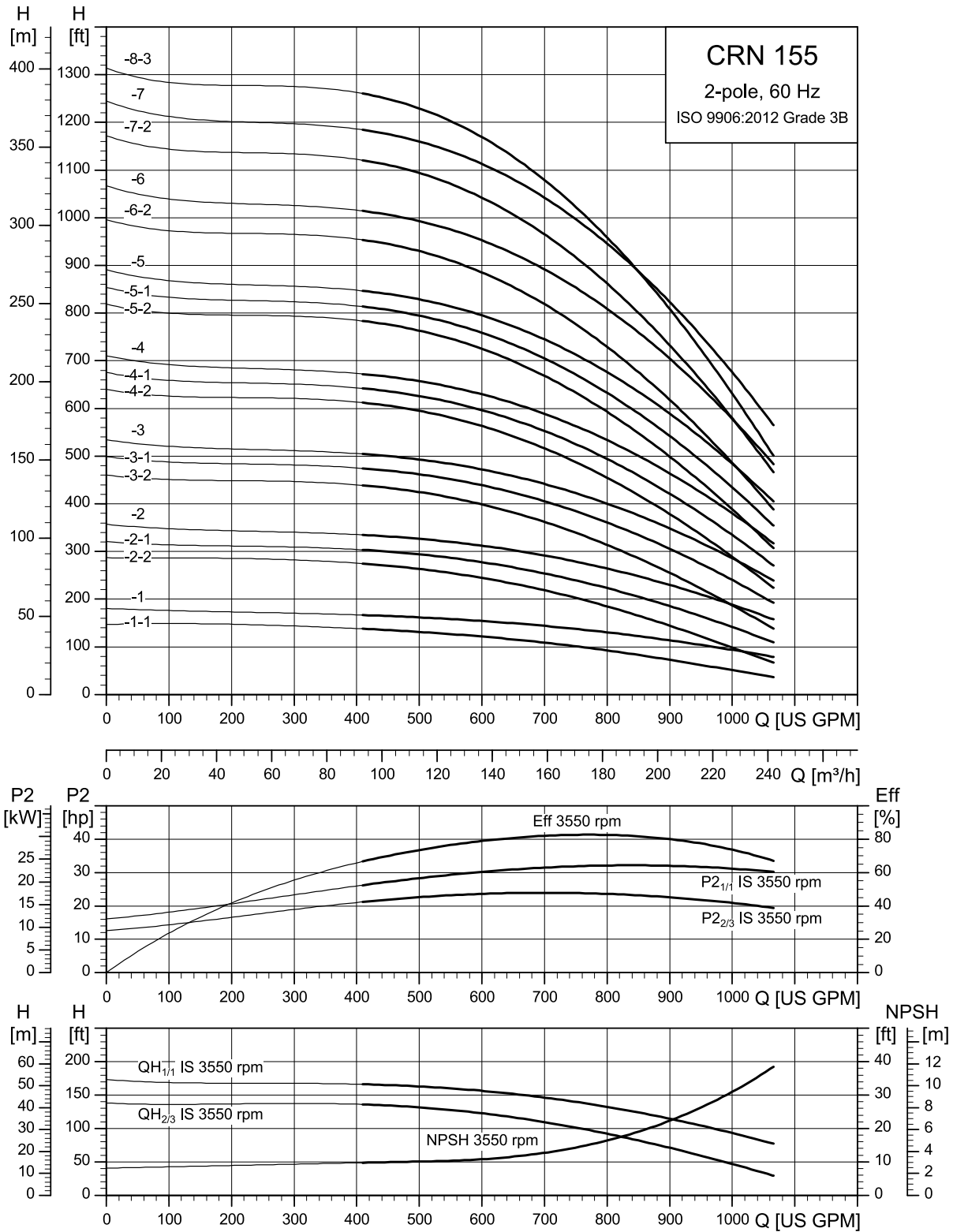

The maximum pump efficiency (Eff) is based on a three-stage pump.

TM065542

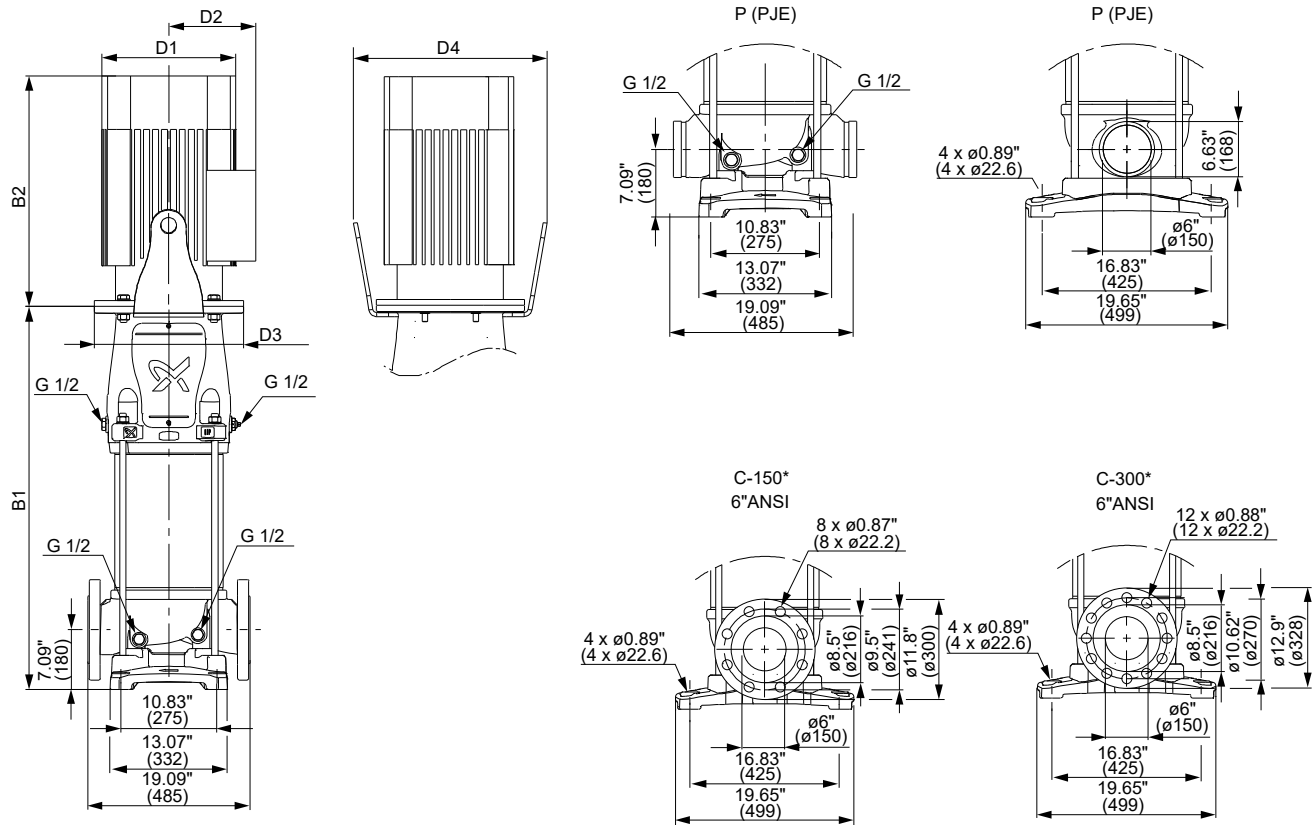

TM066062

* C-150: CRN 155 pumps with up to three stages (with two reduced-diameter impellers) are fitted with class 150 flanges as standard. Class 300 flanges are available on request.

* C-300: CRN 155 pumps with three stages (with one reduced-diameter impeller) or more stages are fitted with class 300 flanges as standard.

Dimensions and weights

Pump type	Motor [HP]	Dimensions [inch (mm)]						Net weight [lbs (kg)]
		B1	B1+B2	D1	D2	D3	D4	
CRN 155-1-1	25	30.9 (785)	54.5 (1384)	14.2 (360)	11.1 (282)	15.7 (400)	19.4 (492)	738 (335)
CRN 155-1	40	31.8 (808)	57.9 (1471)	15.8 (402)	12.6 (320)	17.7 (450)	22.6 (573)	895 (406)
CRN 155-2-2	50	36.6 (930)	62.7 (1593)	15.8 (402)	12.6 (320)	17.7 (450)	22.6 (573)	952 (432)
CRN 155-2-1	60	36.6 (930)	65.4 (1662)	17.9 (455)	16.0 (407)	17.7 (450)	22.6 (573)	1242 (563)
CRN 155-2	75	36.6 (930)	65.4 (1662)	17.9 (455)	16.0 (407)	17.7 (450)	22.6 (573)	1245 (565)
CRN 155-3-2	75	41.4 (1052)	70.2 (1784)	17.9 (455)	16.0 (407)	17.7 (450)	22.6 (573)	1269 (576)
CRN 155-3-1	100	41.4 (1051)	73.9 (1876)	19.1 (486)	16.0 (407)	21.7 (550)	36.1 (918)	1672 (758)
CRN 155-3	100	41.4 (1051)	73.9 (1876)	19.1 (486)	16.0 (407)	21.7 (550)	36.1 (918)	1672 (758)
CRN 155-4-2	125	46.2 (1173)	82.8 (2104)	23.6 (599)	18.6 (472)	21.7 (550)	36.1 (918)	2229 (1011)
CRN 155-4-1	125	46.2 (1173)	82.8 (2104)	23.6 (599)	18.6 (472)	21.7 (550)	36.1 (918)	2229 (1011)
CRN 155-4	125	46.2 (1173)	82.8 (2104)	23.6 (599)	18.6 (472)	21.7 (550)	36.1 (918)	2229 (1011)
CRN 155-5-2	150	51.0 (1295)	87.6 (2226)	23.6 (599)	18.6 (472)	21.7 (550)	36.1 (918)	2367 (1074)
CRN 155-5-1	150	51.0 (1295)	87.6 (2226)	23.6 (599)	18.6 (472)	21.7 (550)	36.1 (918)	2367 (1074)
CRN 155-5 ¹⁷⁾	200	51.0 (1295)	94.1 (2390)	26.0 (660)	24.0 (609)	21.7 (550)	36.1 (918)	2757 (1250)
CRN 155-6-2 ¹⁷⁾	200	55.8 (1417)	104 (2635)	23.6 (599)	20.6 (522)	21.7 (550)	36.1 (918)	2857 (1296)
CRN 155-6 ¹⁷⁾	200	55.8 (1417)	104 (2635)	23.6 (599)	20.6 (522)	21.7 (550)	36.1 (918)	2857 (1296)
CRN 155-7-2 ¹⁷⁾	200	60.6 (1539)	109 (2757)	23.6 (599)	20.6 (522)	21.7 (550)	36.1 (918)	2880 (1307)
CRN 155-7 ¹⁷⁾	250	60.6 (1539)	109 (2757)	23.6 (599)	20.6 (522)	21.7 (550)	36.1 (918)	3125 (1417)
CRN 155-8-3 ¹⁷⁾	250	65.4 (1661)	113 (2879)	23.6 (599)	20.6 (522)	21.7 (550)	36.1 (918)	3149 (1428)

¹⁷⁾ Only to be used with soft starter or frequency converter.

CR 185

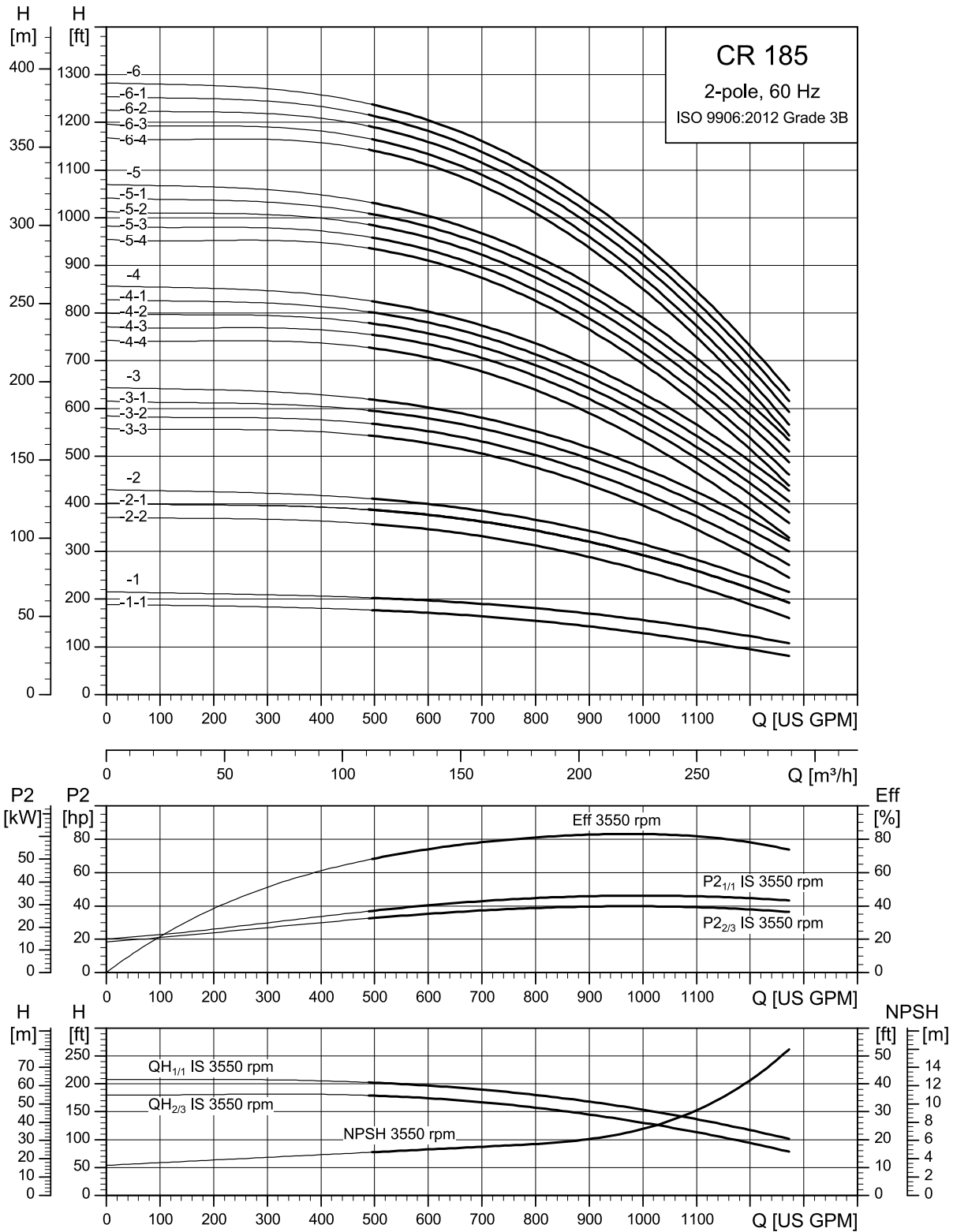

The maximum pump efficiency (Eff) is based on a three-stage pump.

TM065543

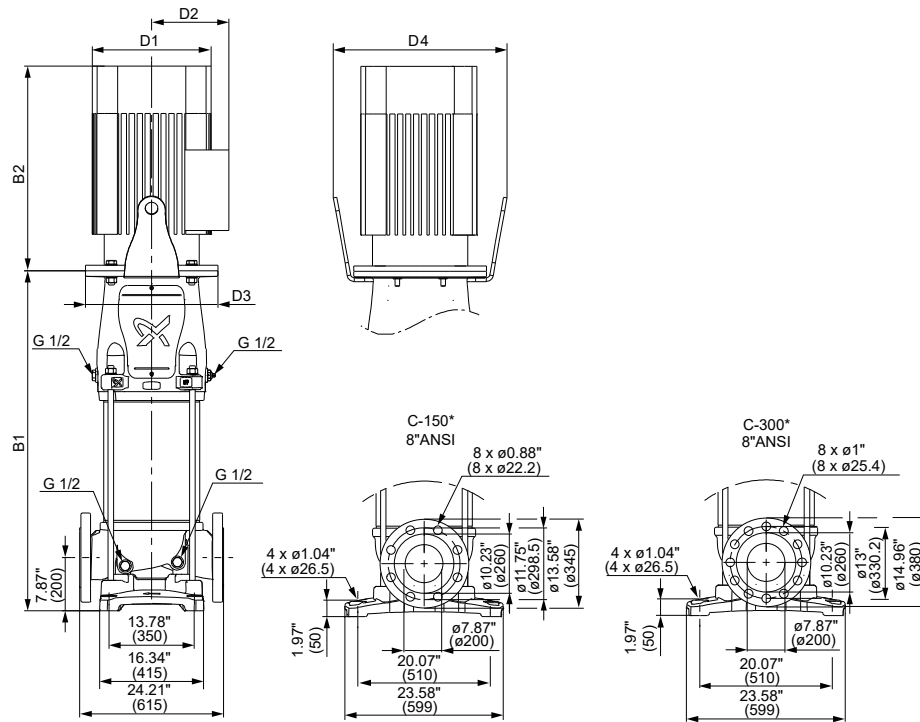

TM077445

* C-150: CR 185 pumps with up to two stages are fitted with class 150 flanges as standard. Class 300 flanges are available on request.

* C-300: CR 185 pumps with three or more stages are fitted with class 300 flanges as standard.

Dimensions and weights

Pump type	Motor [HP]	Dimensions [inch (mm)]						Net weight [lbs (kg)]
		B1	B1+B2	D1	D2	D3	D4	
CR 185-1-1	40	34.6 (878)	60.7 (1541)	15.8 (402)	12.6 (320)	17.7 (450)	22.6 (573)	1092 (495)
CR 185-1	50	34.6 (878)	60.7 (1541)	15.8 (402)	12.6 (320)	17.7 (450)	22.6 (573)	1126 (511)
CR 185-2-2	75	39.6 (1006)	68.4 (1738)	17.9 (455)	16.0 (407)	17.7 (450)	22.6 (573)	1451 (658)
CR 185-2-1	100	39.8 (1012)	72.3 (1837)	19.1 (486)	16.0 (407)	21.7 (550)	36.1 (918)	1828 (829)
CR 185-2	100	39.8 (1012)	72.3 (1837)	19.1 (486)	16.0 (407)	21.7 (550)	36.1 (918)	1828 (829)
CR 185-3-3	125	44.9 (1140)	81.5 (2071)	23.6 (599)	18.6 (472)	21.7 (550)	36.1 (918)	2426 (1101)
CR 185-3-2	125	44.9 (1140)	81.5 (2071)	23.6 (599)	18.6 (472)	21.7 (550)	36.1 (918)	2426 (1101)
CR 185-3-1	150	44.9 (1140)	81.5 (2071)	23.6 (599)	18.6 (472)	21.7 (550)	36.1 (918)	2541 (1152)
CR 185-3	150	44.9 (1140)	81.5 (2071)	23.6 (599)	18.6 (472)	21.7 (550)	36.1 (918)	2541 (1152)
CR 185-4-4	150	49.9 (1268)	86.6 (2199)	23.6 (599)	18.6 (472)	21.7 (550)	36.1 (918)	2573 (1167)
CR 185-4-3	200	49.9 (1268)	97.9 (2486)	23.6 (599)	20.6 (522)	21.7 (550)	36.1 (918)	3038 (1378)
CR 185-4-2	200	49.9 (1268)	97.9 (2486)	23.6 (599)	20.6 (522)	21.7 (550)	36.1 (918)	3038 (1378)
CR 185-4-1	200	49.9 (1268)	97.9 (2486)	23.6 (599)	20.6 (522)	21.7 (550)	36.1 (918)	3038 (1378)
CR 185-4	200	49.9 (1268)	97.9 (2486)	23.6 (599)	20.6 (522)	21.7 (550)	36.1 (918)	3038 (1378)
CR 185-5-4	200	55.0 (1396)	103 (2614)	23.6 (599)	20.6 (522)	21.7 (550)	36.1 (918)	3071 (1393)
CR 185-5-3	200	55.0 (1396)	103 (2614)	23.6 (599)	20.6 (522)	21.7 (550)	36.1 (918)	3071 (1393)
CR 185-5-2	250	55.0 (1396)	103 (2614)	23.6 (599)	20.6 (522)	21.7 (550)	36.1 (918)	3315 (1504)
CR 185-5-1	250	55.0 (1396)	103 (2614)	23.6 (599)	20.6 (522)	21.7 (550)	36.1 (918)	3315 (1504)
CR 185-5	250	55.0 (1396)	103 (2614)	23.6 (599)	20.6 (522)	21.7 (550)	36.1 (918)	3315 (1504)
CR 185-6-4	250	60.0 (1524)	108 (2742)	23.6 (599)	20.6 (522)	21.7 (550)	36.1 (918)	3348 (1518)
CR 185-6-3	250	60.0 (1524)	108 (2742)	23.6 (599)	20.6 (522)	21.7 (550)	36.1 (918)	3348 (1518)
CR 185-6-2	300	60.0 (1524)	108 (2742)	23.6 (599)	20.6 (522)	21.7 (550)	36.1 (918)	3655 (1658)
CR 185-6-1	300	60.0 (1524)	108 (2742)	23.6 (599)	20.6 (522)	21.7 (550)	36.1 (918)	3655 (1658)
CR 185-6	300	60.0 (1524)	108 (2742)	23.6 (599)	20.6 (522)	21.7 (550)	36.1 (918)	3655 (1658)

CRN 185

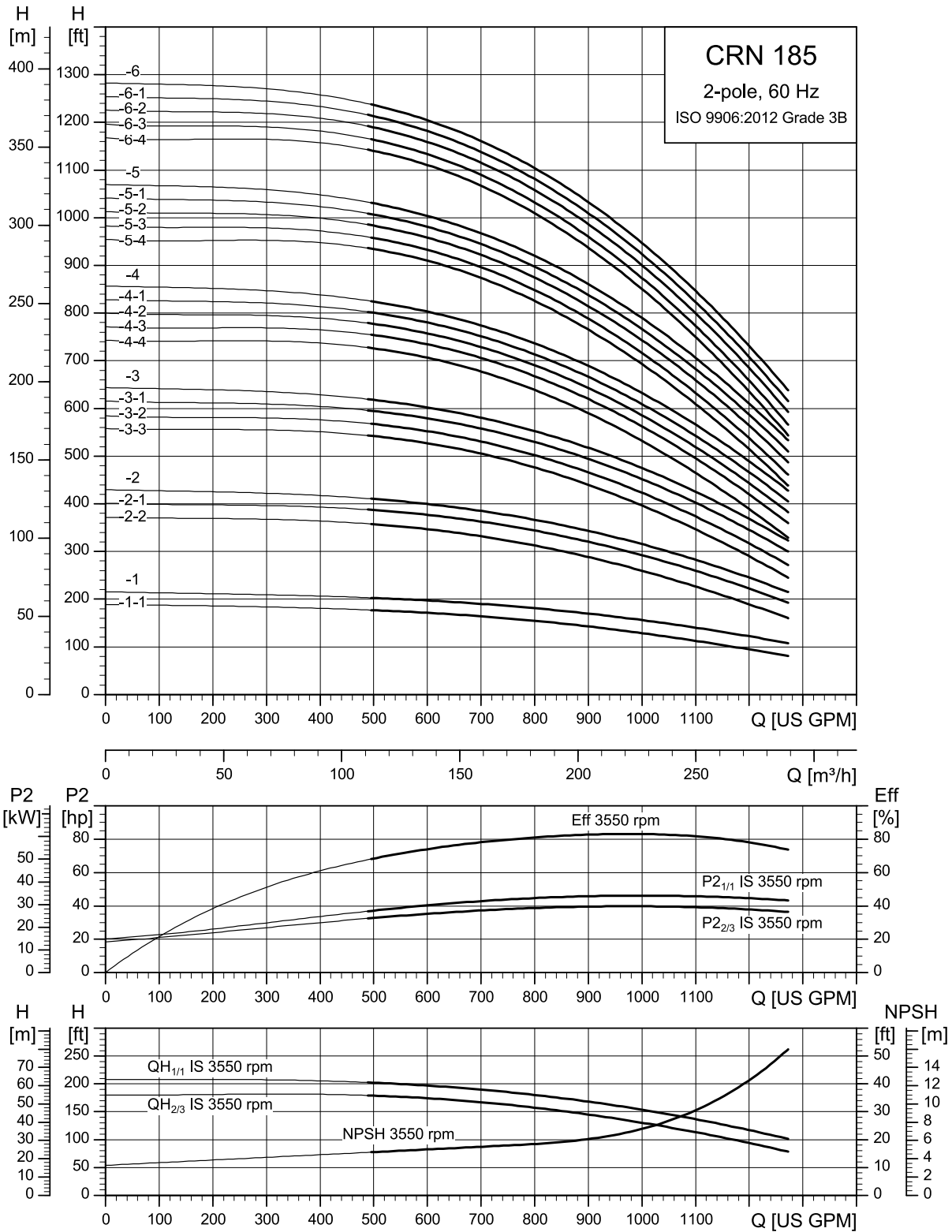

The maximum pump efficiency (Eff) is based on a three-stage pump.

TM065544

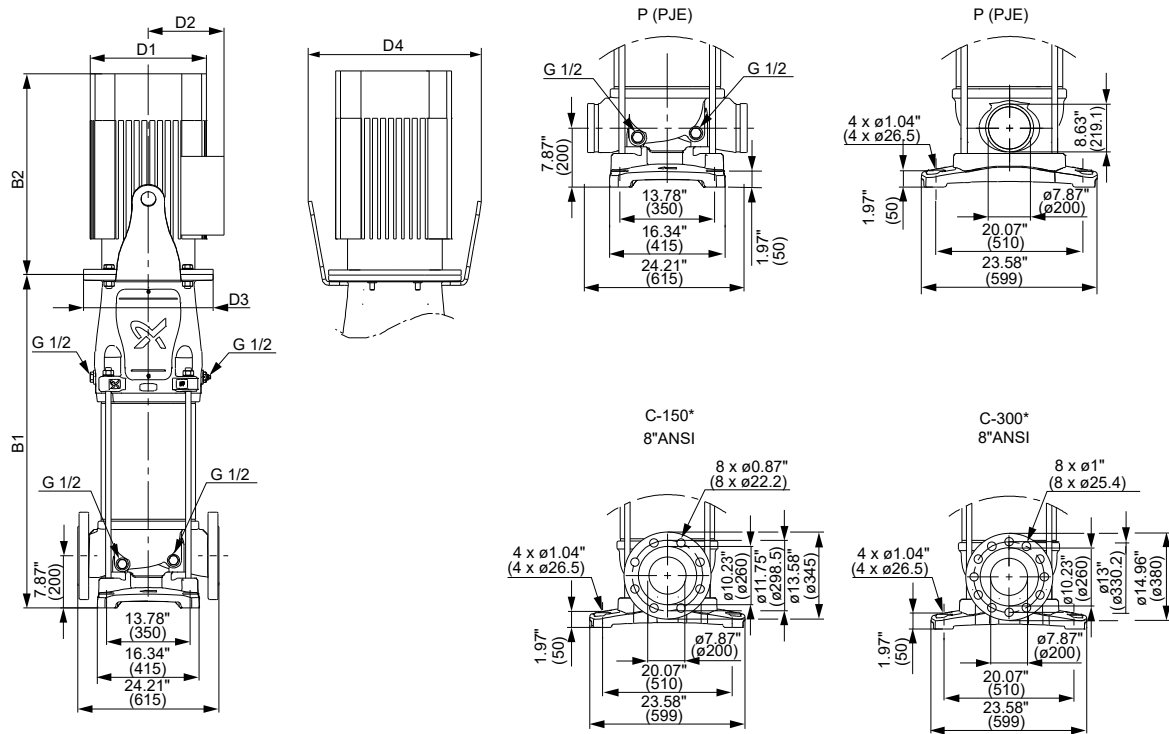

* C-150: CRN 185 pumps with up to two stages are fitted with class 150 flanges as standard. Class 300 flanges are available on request.

* C-300: CRN 185 pumps with three or more stages are fitted with class 300 flanges as standard.

Dimensions and weights

Pump type	Motor [HP]	Dimensions [inch (mm)]						Net weight [lbs (kg)]
		B1	B1+B2	D1	D2	D3	D4	
CRN 185-1-1	40	34.6 (878)	60.7 (1541)	15.8 (402)	12.6 (320)	17.7 (450)	22.6 (573)	1092 (495)
CRN 185-1	50	34.6 (878)	60.7 (1541)	15.8 (402)	12.6 (320)	17.7 (450)	22.6 (573)	1126 (511)
CRN 185-2-2	75	39.6 (1006)	68.4 (1738)	17.9 (455)	16.0 (407)	17.7 (450)	22.6 (573)	1451 (658)
CRN 185-2-1	100	39.8 (1012)	72.3 (1837)	19.1 (486)	16.0 (407)	21.7 (550)	36.1 (918)	1828 (829)
CRN 185-2	100	39.8 (1012)	72.3 (1837)	19.1 (486)	16.0 (407)	21.7 (550)	36.1 (918)	1828 (829)
CRN 185-3-3	125	44.9 (1140)	81.5 (2071)	23.6 (599)	18.6 (472)	21.7 (550)	36.1 (918)	2426 (1101)
CRN 185-3-2	125	44.9 (1140)	81.5 (2071)	23.6 (599)	18.6 (472)	21.7 (550)	36.1 (918)	2426 (1101)
CRN 185-3-1	150	44.9 (1140)	81.5 (2071)	23.6 (599)	18.6 (472)	21.7 (550)	36.1 (918)	2541 (1152)
CRN 185-3	150	44.9 (1140)	81.5 (2071)	23.6 (599)	18.6 (472)	21.7 (550)	36.1 (918)	2541 (1152)
CRN 185-4-4	150	49.9 (1268)	86.6 (2199)	23.6 (599)	18.6 (472)	21.7 (550)	36.1 (918)	2573 (1167)
CRN 185-4-3	200	49.9 (1268)	97.9 (2486)	23.6 (599)	20.6 (522)	21.7 (550)	36.1 (918)	3038 (1378)
CRN 185-4-2	200	49.9 (1268)	97.9 (2486)	23.6 (599)	20.6 (522)	21.7 (550)	36.1 (918)	3038 (1378)
CRN 185-4-1	200	49.9 (1268)	97.9 (2486)	23.6 (599)	20.6 (522)	21.7 (550)	36.1 (918)	3038 (1378)
CRN 185-4	200	49.9 (1268)	97.9 (2486)	23.6 (599)	20.6 (522)	21.7 (550)	36.1 (918)	3038 (1378)
CRN 185-5-4	200	55.0 (1396)	103 (2614)	23.6 (599)	20.6 (522)	21.7 (550)	36.1 (918)	3071 (1393)
CRN 185-5-3	200	55.0 (1396)	103 (2614)	23.6 (599)	20.6 (522)	21.7 (550)	36.1 (918)	3071 (1393)
CRN 185-5-2	250	55.0 (1396)	103 (2614)	23.6 (599)	20.6 (522)	21.7 (550)	36.1 (918)	3315 (1504)
CRN 185-5-1	250	55.0 (1396)	103 (2614)	23.6 (599)	20.6 (522)	21.7 (550)	36.1 (918)	3315 (1504)
CRN 185-5	250	55.0 (1396)	103 (2614)	23.6 (599)	20.6 (522)	21.7 (550)	36.1 (918)	3315 (1504)
CRN 185-6-4	250	60.0 (1524)	108 (2742)	23.6 (599)	20.6 (522)	21.7 (550)	36.1 (918)	3348 (1518)
CRN 185-6-3	250	60.0 (1524)	108 (2742)	23.6 (599)	20.6 (522)	21.7 (550)	36.1 (918)	3348 (1518)
CRN 185-6-2	300	60.0 (1524)	108 (2742)	23.6 (599)	20.6 (522)	21.7 (550)	36.1 (918)	3655 (1658)
CRN 185-6-1	300	60.0 (1524)	108 (2742)	23.6 (599)	20.6 (522)	21.7 (550)	36.1 (918)	3655 (1658)
CRN 185-6	300	60.0 (1524)	108 (2742)	23.6 (599)	20.6 (522)	21.7 (550)	36.1 (918)	3655 (1658)

TM077446

CR 215

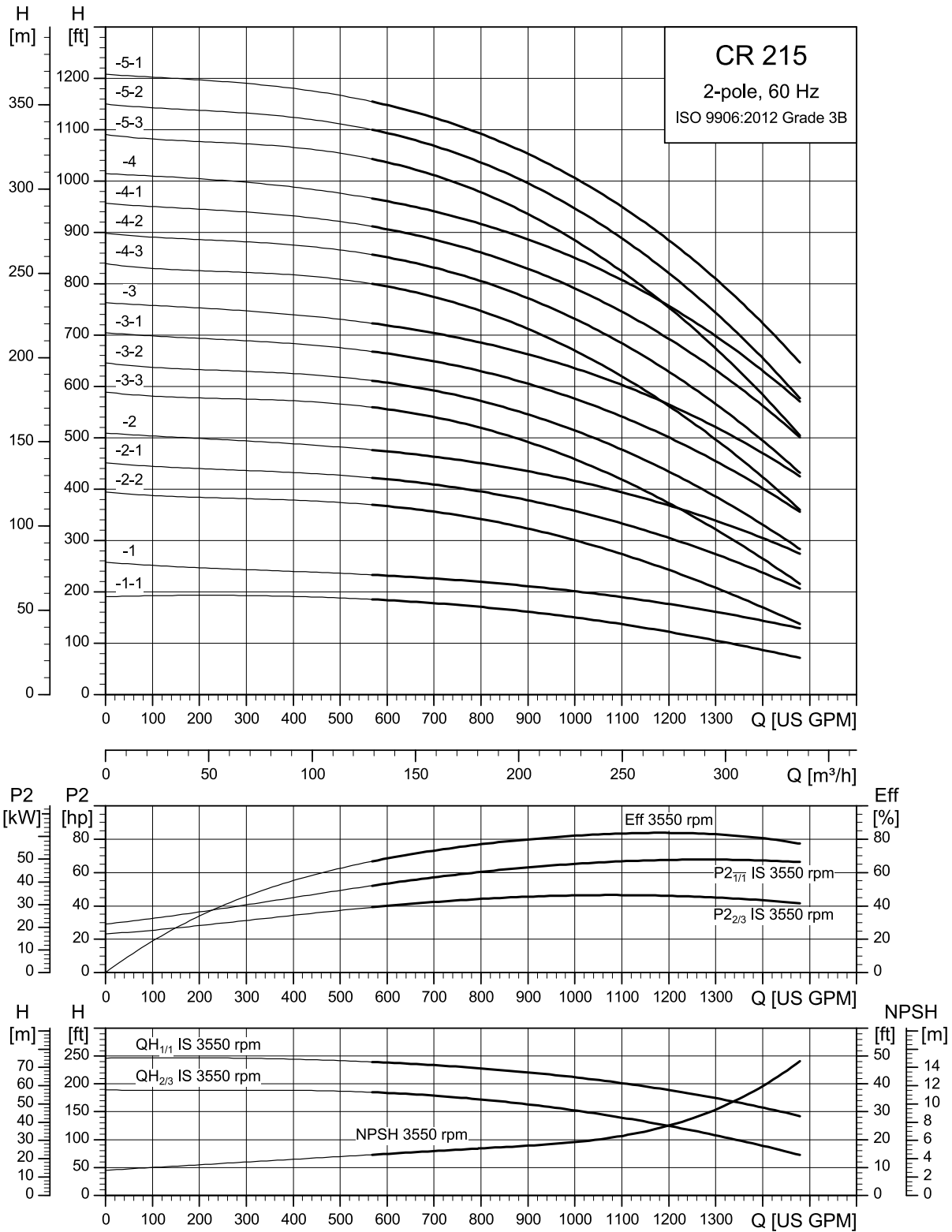

The maximum pump efficiency (Eff) is based on a three-stage pump.

TM065545

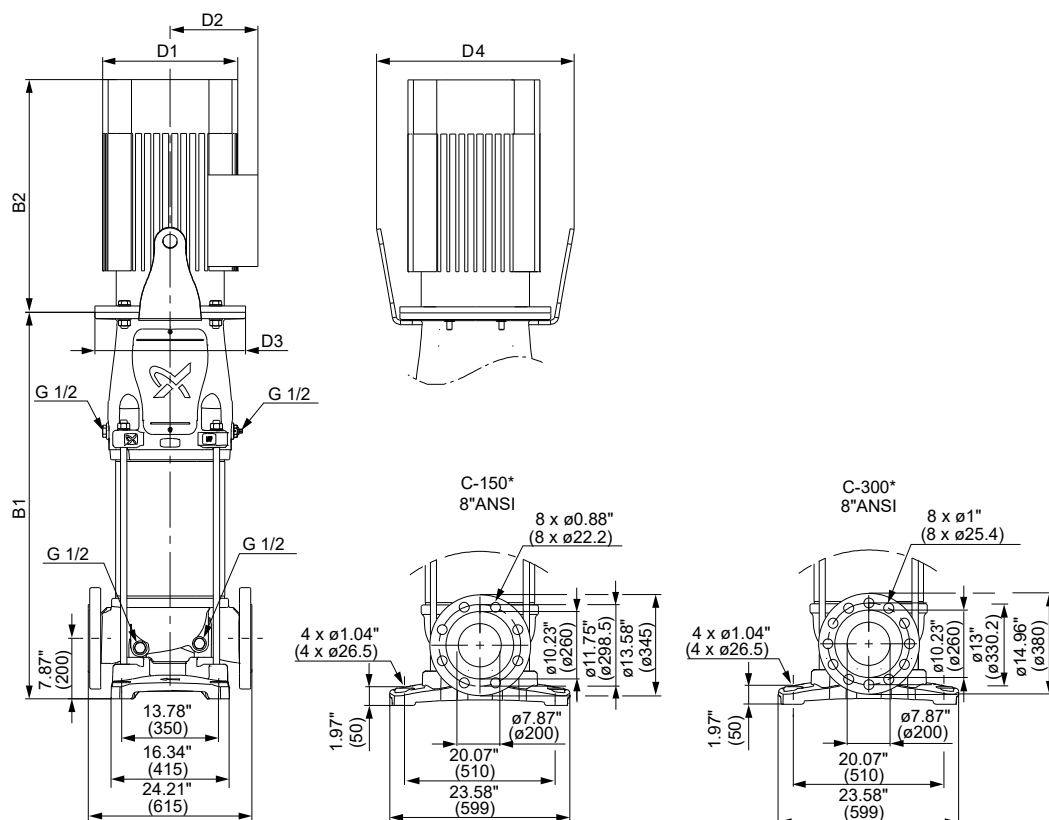

TM077445

* C-150: CR 215 pumps with up to two stages are fitted with class 150 flanges as standard. Class 300 flanges are available on request.

* C-300: CR 215 pumps with three or more stages are fitted with class 300 flanges as standard.

Dimensions and weights

Pump type	Motor [HP]	Dimensions [inch (mm)]						Net weight [lbs (kg)]
		B1	B1+B2	D1	D2	D3	D4	
CR 215-1-1	50	34.6 (878)	60.7 (1541)	15.8 (402)	12.6 (320)	17.7 (450)	22.6 (573)	1127 (511)
CR 215-1	75	34.6 (878)	63.4 (1610)	17.9 (455)	16.0 (407)	17.7 (450)	22.6 (573)	1420 (644)
CR 215-2-2	100	39.8 (1012)	72.3 (1837)	19.1 (486)	16.0 (407)	21.7 (550)	36.1 (918)	1831 (831)
CR 215-2-1	125	39.8 (1012)	76.5 (1943)	23.6 (599)	18.6 (472)	21.7 (550)	36.1 (918)	2366 (1073)
CR 215-2	125	39.8 (1012)	76.5 (1943)	23.6 (599)	18.6 (472)	21.7 (550)	36.1 (918)	2366 (1073)
CR 215-3-3	150	44.9 (1140)	81.5 (2071)	23.6 (599)	18.6 (472)	21.7 (550)	36.1 (918)	2545 (1155)
CR 215-3-2	150	44.9 (1140)	81.5 (2071)	23.6 (599)	18.6 (472)	21.7 (550)	36.1 (918)	2545 (1155)
CR 215-3-1	200	44.9 (1140)	92.8 (2358)	23.6 (599)	20.6 (522)	21.7 (550)	36.1 (918)	3011 (1366)
CR 215-3	200	44.9 (1140)	92.8 (2358)	23.6 (599)	20.6 (522)	21.7 (550)	36.1 (918)	3011 (1366)
CR 215-4-3	200	49.9 (1268)	97.9 (2486)	23.6 (599)	20.6 (522)	21.7 (550)	36.1 (918)	3045 (1381)
CR 215-4-2	250	49.9 (1268)	97.9 (2486)	23.6 (599)	20.6 (522)	21.7 (550)	36.1 (918)	3289 (1492)
CR 215-4-1	250	49.9 (1268)	97.9 (2486)	23.6 (599)	20.6 (522)	21.7 (550)	36.1 (918)	3289 (1492)
CR 215-4	250	49.9 (1268)	97.9 (2486)	23.6 (599)	20.6 (522)	21.7 (550)	36.1 (918)	3289 (1492)
CR 215-5-3	250	55.0 (1396)	103 (2614)	23.6 (599)	20.6 (522)	21.7 (550)	36.1 (918)	3323 (1507)
CR 215-5-2	300	55.0 (1396)	103 (2614)	23.6 (599)	20.6 (522)	21.7 (550)	36.1 (918)	3631 (1647)
CR 215-5-1	300	55.0 (1396)	103 (2614)	23.6 (599)	20.6 (522)	21.7 (550)	36.1 (918)	3631 (1647)

CRN 215

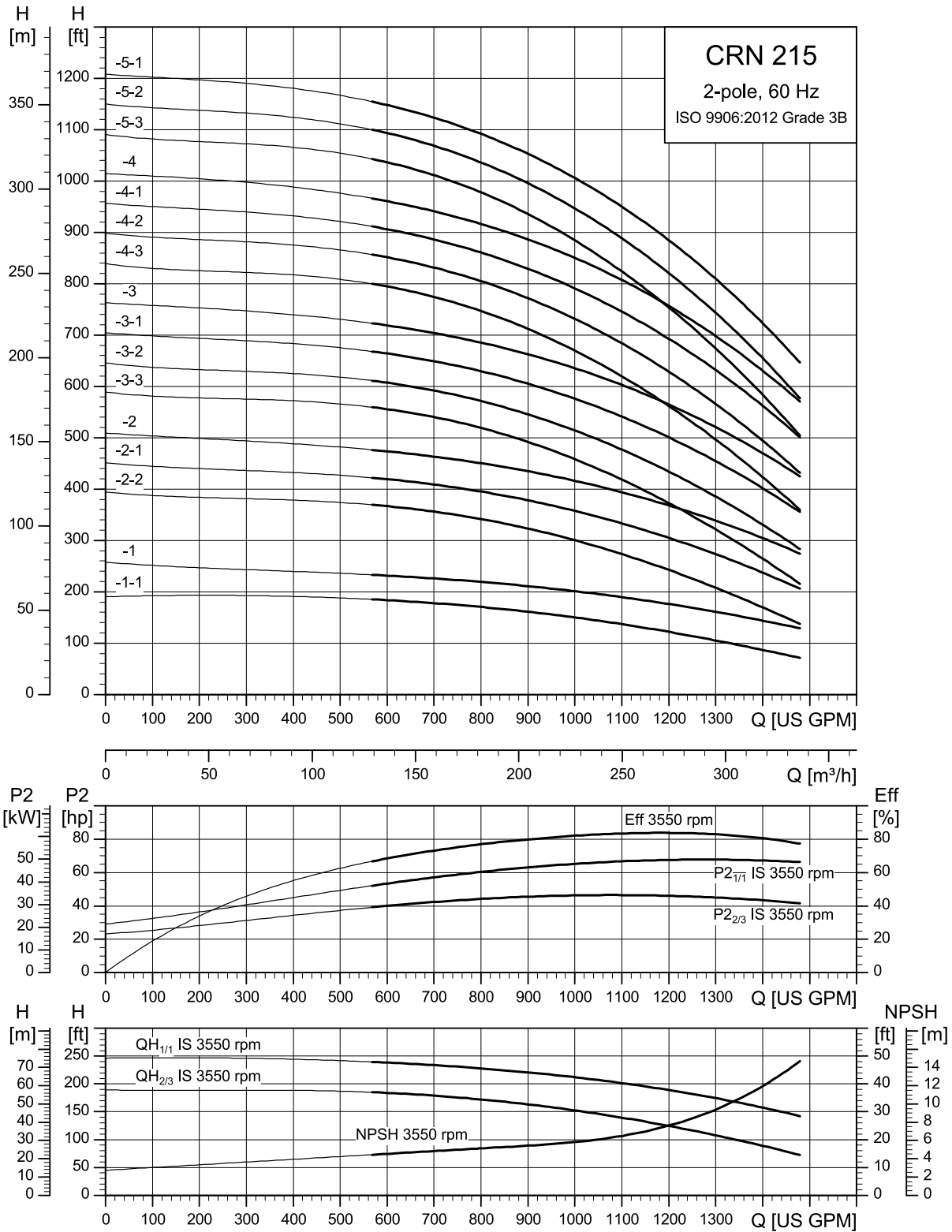

The maximum pump efficiency (Eff) is based on a three-stage pump.

TM065546

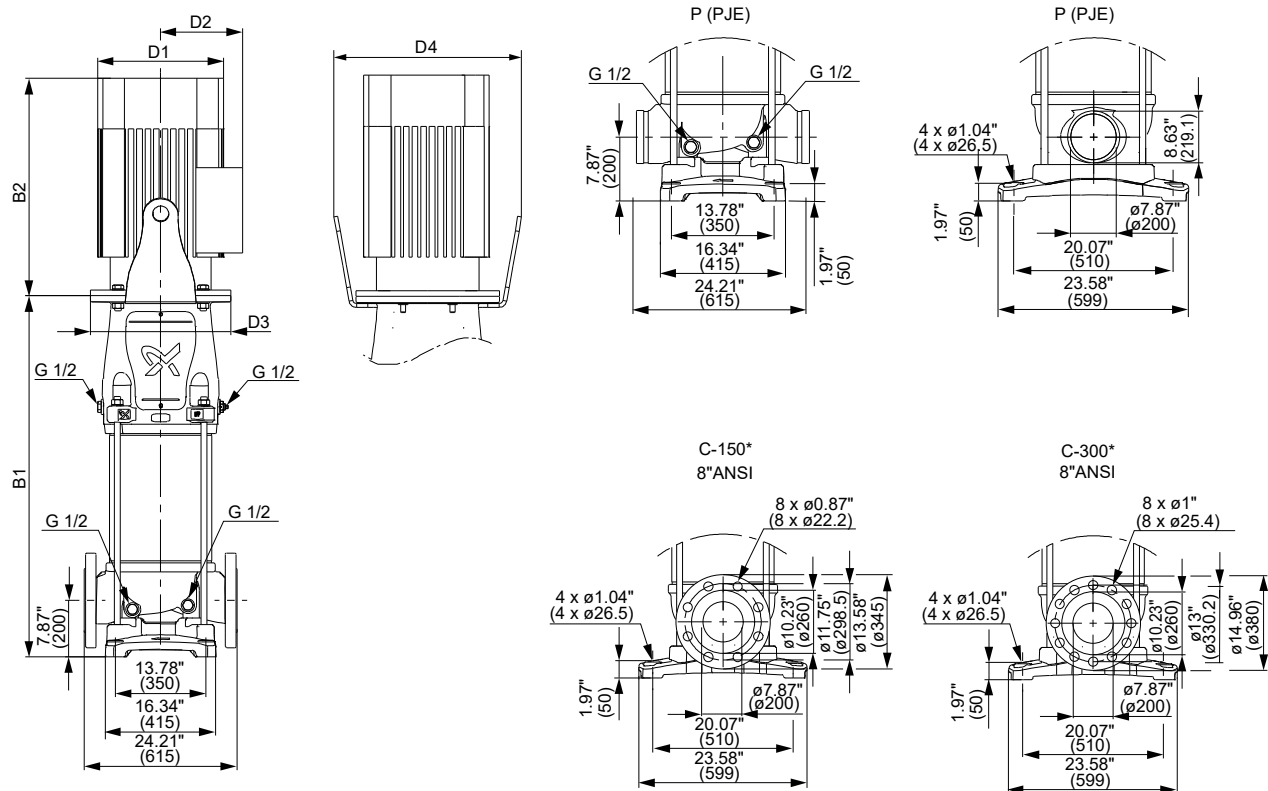

TM077446

* C-150: CRN 215 pumps with up to two stages are fitted with class 150 flanges as standard. Class 300 flanges are available on request.

* C-300: CRN 215 pumps with three or more stages are fitted with class 300 flanges as standard.

Dimensions and weights

Pump type	Motor [HP]	Dimensions [inch (mm)]						Net weight [lbs (kg)]
		B1	B1+B2	D1	D2	D3	D4	
CRN 215-1-1	50	34.6 (878)	60.7 (1541)	15.8 (402)	12.6 (320)	17.7 (450)	22.6 (573)	1127 (511)
CRN 215-1	75	34.6 (878)	63.4 (1610)	17.9 (455)	16.0 (407)	17.7 (450)	22.6 (573)	1420 (644)
CRN 215-2-2	100	39.8 (1012)	72.3 (1837)	19.1 (486)	16.0 (407)	21.7 (550)	36.1 (918)	1831 (831)
CRN 215-2-1	125	39.8 (1012)	76.5 (1943)	23.6 (599)	18.6 (472)	21.7 (550)	36.1 (918)	2366 (1073)
CRN 215-2	125	39.8 (1012)	76.5 (1943)	23.6 (599)	18.6 (472)	21.7 (550)	36.1 (918)	2366 (1073)
CRN 215-3-3	150	44.9 (1140)	81.5 (2071)	23.6 (599)	18.6 (472)	21.7 (550)	36.1 (918)	2545 (1155)
CRN 215-3-2	150	44.9 (1140)	81.5 (2071)	23.6 (599)	18.6 (472)	21.7 (550)	36.1 (918)	2545 (1155)
CRN 215-3-1	200	44.9 (1140)	92.8 (2358)	23.6 (599)	20.6 (522)	21.7 (550)	36.1 (918)	3011 (1366)
CRN 215-3	200	44.9 (1140)	92.8 (2358)	23.6 (599)	20.6 (522)	21.7 (550)	36.1 (918)	3011 (1366)
CRN 215-4-3	200	49.9 (1268)	97.9 (2486)	23.6 (599)	20.6 (522)	21.7 (550)	36.1 (918)	3045 (1381)
CRN 215-4-2	250	49.9 (1268)	97.9 (2486)	23.6 (599)	20.6 (522)	21.7 (550)	36.1 (918)	3289 (1492)
CRN 215-4-1	250	49.9 (1268)	97.9 (2486)	23.6 (599)	20.6 (522)	21.7 (550)	36.1 (918)	3289 (1492)
CRN 215-4	250	49.9 (1268)	97.9 (2486)	23.6 (599)	20.6 (522)	21.7 (550)	36.1 (918)	3289 (1492)
CRN 215-5-3	250	55.0 (1396)	103 (2614)	23.6 (599)	20.6 (522)	21.7 (550)	36.1 (918)	3323 (1507)
CRN 215-5-2	300	55.0 (1396)	103 (2614)	23.6 (599)	20.6 (522)	21.7 (550)	36.1 (918)	3631 (1647)
CRN 215-5-1	300	55.0 (1396)	103 (2614)	23.6 (599)	20.6 (522)	21.7 (550)	36.1 (918)	3631 (1647)

CR 255

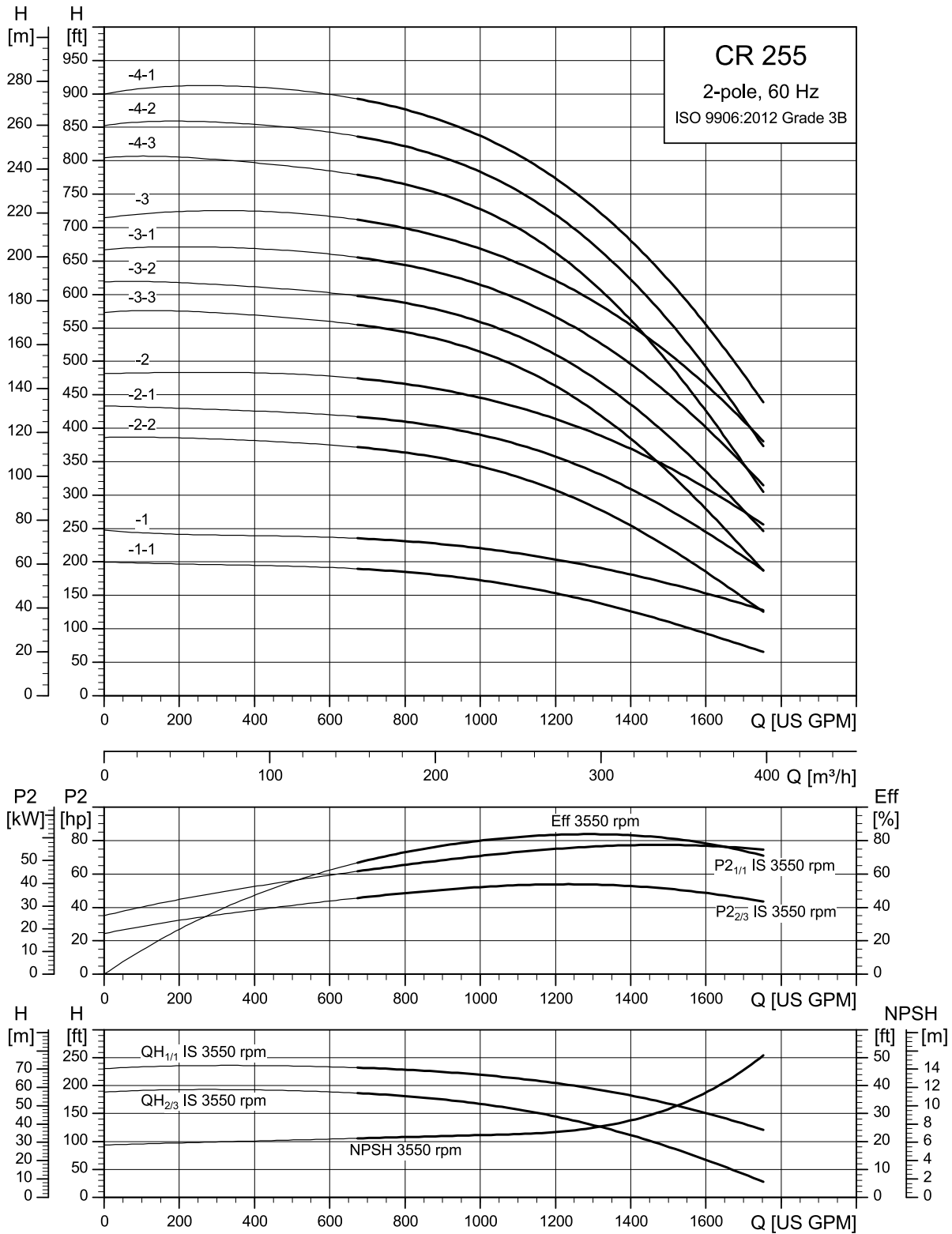

TM065547

The maximum pump efficiency (Eff) is based on a three-stage pump.

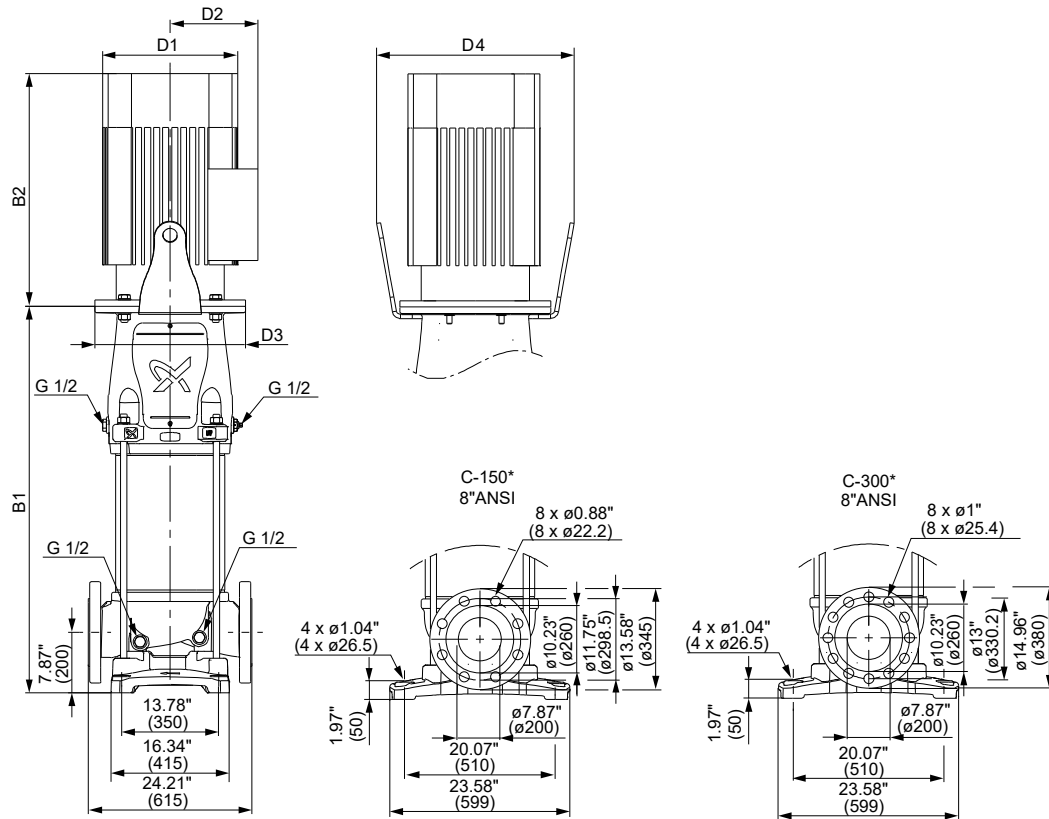

TM077445

* C-150: CR 255 pumps with up to two stages with one reduced-diameter impeller are fitted with class 150 flanges as standard. Class 300 flanges are available on request.

* C-300: CR 255 pumps with two or more stages are fitted with class 300 flanges as standard.

Dimensions and weights

Pump type	Motor [HP]	Dimensions [inch (mm)]						Net weight [lbs (kg)]
		B1	B1+B2	D1	D2	D3	D4	
CR 255-1-1	60	34.6 (878)	63.4 (1610)	17.9 (455)	16.0 (407)	17.7 (450)	22.6 (573)	1417 (643)
CR 255-1	100	34.8 (884)	67.3 (1709)	19.1 (486)	16.0 (407)	21.7 (550)	36.1 (918)	1798 (815)
CR 255-2-2	125	39.8 (1012)	76.5 (1943)	23.6 (599)	18.6 (472)	21.7 (550)	36.1 (918)	2366 (1073)
CR 255-2-1	150	39.8 (1012)	76.5 (1943)	23.6 (599)	18.6 (472)	21.7 (550)	36.1 (918)	2480 (1125)
CR 255-2	200	39.8 (1012)	87.8 (2230)	23.6 (599)	20.6 (522)	21.7 (550)	36.1 (918)	2977 (1350)
CR 255-3-3	200	44.9 (1140)	92.8 (2358)	23.6 (599)	20.6 (522)	21.7 (550)	36.1 (918)	3011 (1366)
CR 255-3-2	200	44.9 (1140)	92.8 (2358)	23.6 (599)	20.6 (522)	21.7 (550)	36.1 (918)	3011 (1366)
CR 255-3-1	250	44.9 (1140)	92.8 (2358)	23.6 (599)	20.6 (522)	21.7 (550)	36.1 (918)	3256 (1477)
CR 255-3	250	44.9 (1140)	92.8 (2358)	23.6 (599)	20.6 (522)	21.7 (550)	36.1 (918)	3256 (1477)
CR 255-4-3	250	49.9 (1268)	97.9 (2486)	23.6 (599)	20.6 (522)	21.7 (550)	36.1 (918)	3289 (1492)
CR 255-4-2	300	49.9 (1268)	97.9 (2486)	23.6 (599)	20.6 (522)	21.7 (550)	36.1 (918)	3597 (1632)
CR 255-4-1	300	49.9 (1268)	97.9 (2486)	23.6 (599)	20.6 (522)	21.7 (550)	36.1 (918)	3597 (1632)

CRN 255

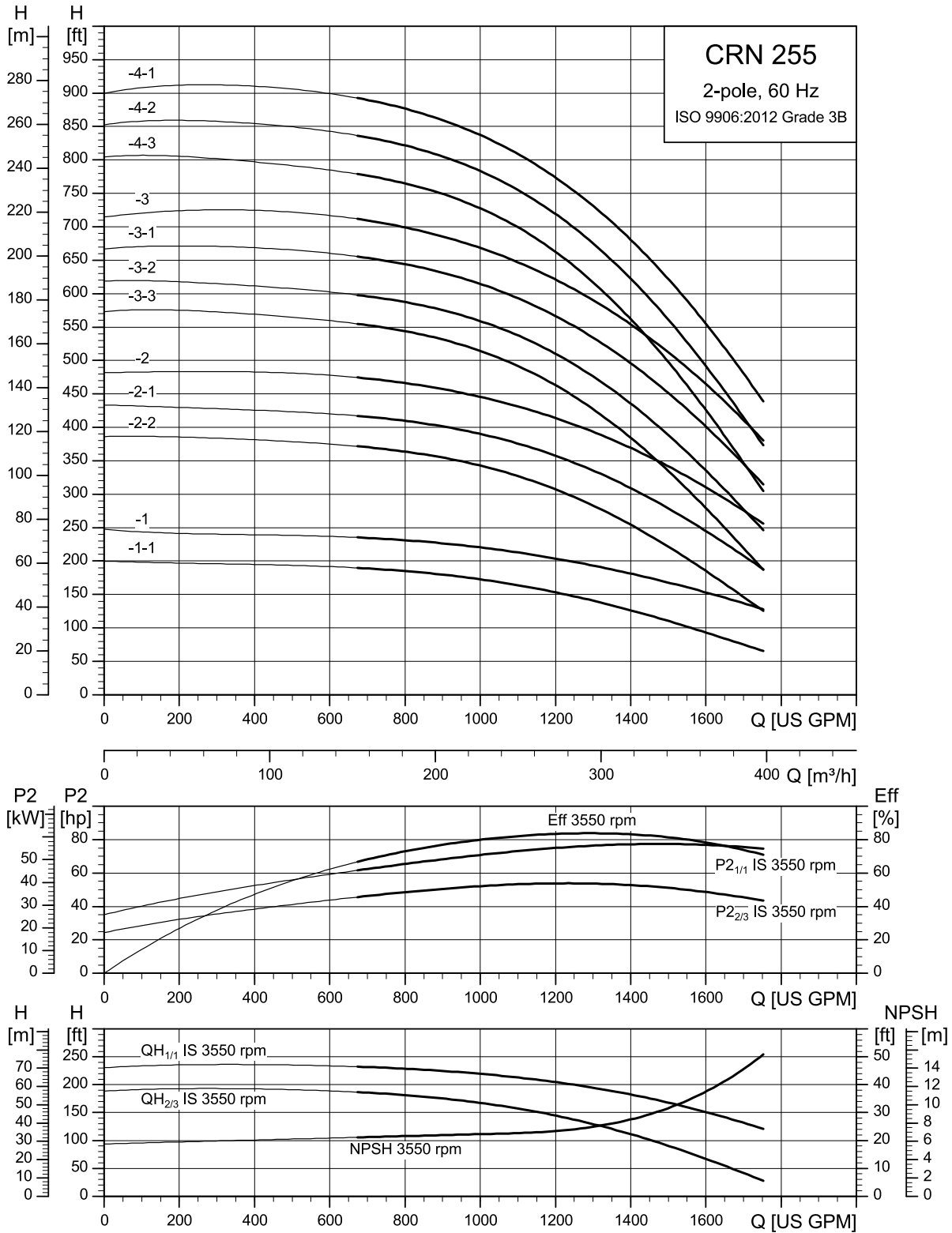

TM065548

The maximum pump efficiency (Eff) is based on a three-stage pump.

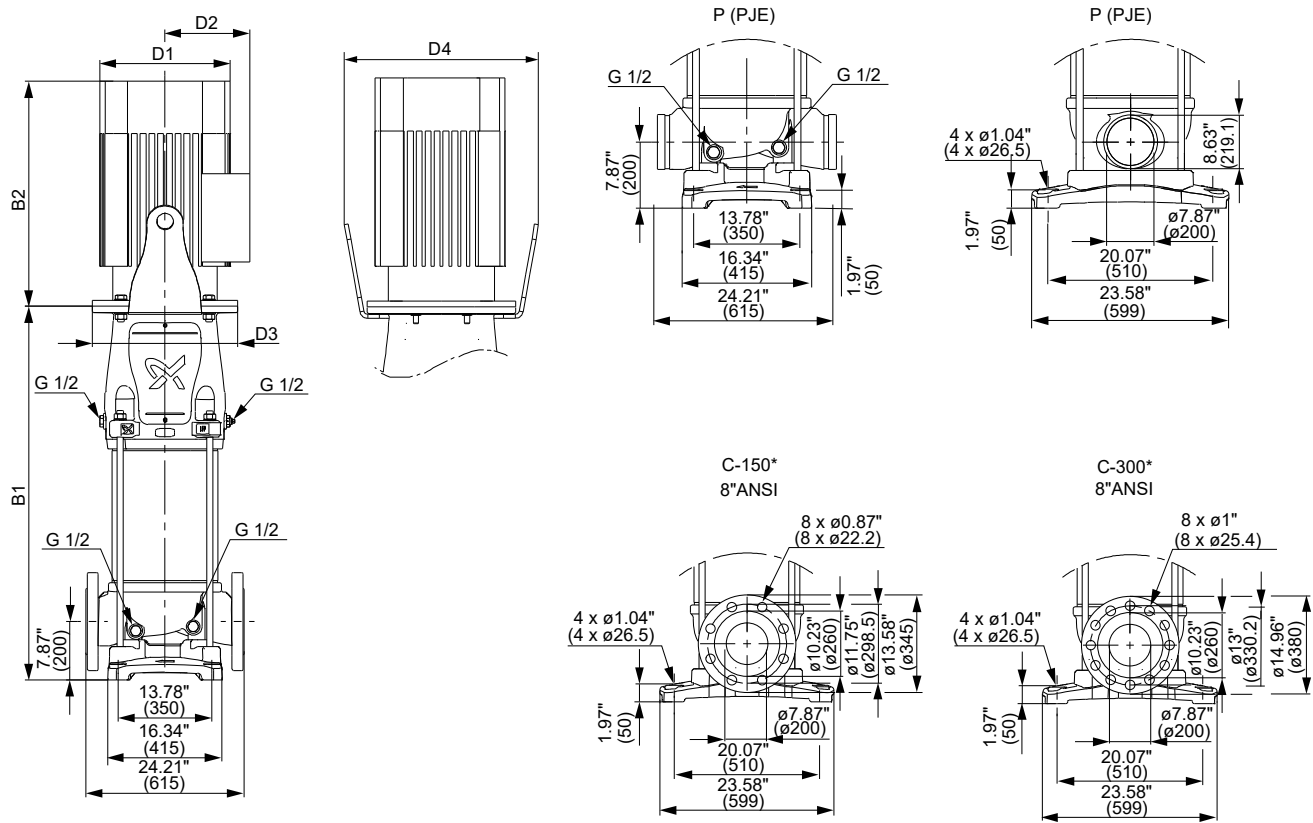

TM077446

* C-150: CRN 255 pumps with up to two stages with one reduced-diameter impeller are fitted with class 150 flanges as standard. Class 300 flanges are available on request.

* C-300: CRN 255 pumps with two or more stages are fitted with class 300 flanges as standard.

Dimensions and weights

Pump type	Motor [HP]	Dimensions [inch (mm)]						Net weight [lbs (kg)]
		B1	B1+B2	D1	D2	D3	D4	
CRN 255-1-1	60	34.6 (878)	63.4 (1610)	17.9 (455)	16.0 (407)	17.7 (450)	22.6 (573)	1417 (643)
CRN 255-1	100	34.8 (884)	67.3 (1709)	19.1 (486)	16.0 (407)	21.7 (550)	36.1 (918)	1798 (815)
CRN 255-2-2	125	39.8 (1012)	76.5 (1943)	23.6 (599)	18.6 (472)	21.7 (550)	36.1 (918)	2366 (1073)
CRN 255-2-1	150	39.8 (1012)	76.5 (1943)	23.6 (599)	18.6 (472)	21.7 (550)	36.1 (918)	2480 (1125)
CRN 255-2	200	39.8 (1012)	87.8 (2230)	23.6 (599)	20.6 (522)	21.7 (550)	36.1 (918)	2977 (1350)
CRN 255-3-3	200	44.9 (1140)	92.8 (2358)	23.6 (599)	20.6 (522)	21.7 (550)	36.1 (918)	3011 (1366)
CRN 255-3-2	200	44.9 (1140)	92.8 (2358)	23.6 (599)	20.6 (522)	21.7 (550)	36.1 (918)	3011 (1366)
CRN 255-3-1	250	44.9 (1140)	92.8 (2358)	23.6 (599)	20.6 (522)	21.7 (550)	36.1 (918)	3256 (1477)
CRN 255-3	250	44.9 (1140)	92.8 (2358)	23.6 (599)	20.6 (522)	21.7 (550)	36.1 (918)	3256 (1477)
CRN 255-4-3	250	49.9 (1268)	97.9 (2486)	23.6 (599)	20.6 (522)	21.7 (550)	36.1 (918)	3289 (1492)
CRN 255-4-2	300	49.9 (1268)	97.9 (2486)	23.6 (599)	20.6 (522)	21.7 (550)	36.1 (918)	3597 (1632)
CRN 255-4-1	300	49.9 (1268)	97.9 (2486)	23.6 (599)	20.6 (522)	21.7 (550)	36.1 (918)	3597 (1632)

9. Motor data

Standard motors in the CR 95-255 range

Motors used in the CR pump range are:

- Grundfos-specified WEG motors
- Grundfos ML motors.

Type	Phase	Motor range [HP]	Enclosure
WEG	3	15 - 300	TEFC
	3	15 - 300	ODP
ML	3	15 - 30	TEFC

WEG motors 0.25 to 20 HP

- rolled steel construction
- service factor 1.15
- suitable for VFD operation per NEMA MG 1 part 31.4.4.2
- certified Class I Division 2, Groups A, B, C, D
- certified Class II, Division 2, Groups F, G (three-phase only).

WEG motors 25 to 300 HP

- cast iron frame
- rated for severe duty
- service factor 1.25 (25 to 100 HP)
- service factor 1.15 (125 to 300 HP)
- Inverter rated per NEMA MG 1 part 31
- certified Class I Division 2, Groups A, B, C, D
- certified Class II, Division 2, Groups F, G.

TEFC motors**Totally Enclosed Fan Cooled, constant speed****WEG motors**

TM077440

HP	Ph	Frame	Service factor	Voltage [V]	Motor eff. η [%]	Full-load current $I_{1/1}$ [A]	Service-factor current [A]	Starting current I_{start} [A]	Power factor $\cos \phi_{1/1}$	Speed [rpm]
15	3	254TC	1.15	230/460	91.0	38.5-34.8/17.4	38.5-40.0/20	262-237/118	0.87	3525
	3	254TC	1.15	575	91.0	13.9	16.0	114	0.89	3520
20	3	256TC	1.15	230/460	91.0	50.2-45.4/22.7	50.2-52.2/26.1	331-300/150	0.91	3515
	3	256TC	1.15	575	91.0	18.2	20.9	120	0.91	3515
25	3	284TSC	1.25	230/460	91.7	63.6-57.6/28.8	63.6-72.0/36	401-363/181	0.88	3545
	3	284TSC	1.25	575	91.7	23	28.8	145	0.88	3545
30	3	286TSC	1.25	230/460	91.7	73.8-67.6/33.8	73.8-84.5/42.3	465-426/213	0.89	3540
	3	286TSC	1.25	575	91.7	27	33.8	170	0.89	3540
40	3	324TSC	1.25	230/460	92.4	101.0-92.6/46.3	101-116/57.9	636-583/292	0.88	3560
	3	324TSC	1.25	575	92.4	37	46.3	233	0.88	3560
50	3	326TSC	1.25	230/460	93.0	124-112/56.1	124-140/70.1	769-694/348	0.89	3550
	3	326TSC	1.25	575	93.0	44.9	56.1	278	0.89	3550
60	3	364TSC	1.25	230/460	93.6	148-134/67	148-168/83.8	977-884/442	0.90	3560
	3	364TSC	1.25	575	93.6	53.6	67.0	354	0.90	3560
75	3	365TSC	1.25	230/460	93.6	181-164/81.9	181-205/102	1213-1099/549	0.90	3555
	3	365TSC	1.25	575	93.6	65.6	82.0	440	0.90	3555
100	3	405TSD	1.25	460	94.1	112	140	728	0.89	3545
	3	405TSD	1.25	575	94.1	89.6	112	582	0.89	3545
125	3	444TSD	1.15	460	95.0	134	154	884	0.89	3570
	3	444TSD	1.15	575	95.0	107	123	706	0.89	3570
150	3	445TSD	1.15	460	95.0	163	187	1060	0.89	3570
	3	445TSD	1.15	575	95.0	130	150	845	0.89	3570
200	3	447TSD	1.15	460	95.4	222	255	1443	0.89	3570
	3	447TSD	1.15	575	95.4	178	205	1157	0.89	3570
250	3	447TSD	1.15	460	95.8	269	309	1802	0.90	3573
	3	447TSD	1.15	575	95.8	215	247	1441	0.90	3573
300	3	449TSD	1.15	460	95.8	320	368	2176	0.90	3570
	3	449TSD	1.15	575	95.8	256	294	1741	0.90	3570

Note that motors listed at 230/460 V in the table are suitable for operation at 208 V.

Grundfos ML motors



GR7845SH

Motor data

HP	Ph	Frame	Service factor	Voltage [V]	Motor eff. η [%]	Full-load current $I_{1/1}$ [A]	Service-factor current [A]	Starting current I_{start} [A]	Power factor $\cos \phi_{1/1}$	Speed [rpm]
15	3	254TC	1.15	208-230/460	91.0	37.5-34.0/17	43-39/19.6	255-306/153	0.91-0.89	3490-3530
20	3	256TC	1.15	208-230/460	91.0	50.5-46.0/23	58-53/26.5	308-373/186	0.92-0.90	3490-3530
25	3	284TSC	1.15	208-230/460	91.7	62-56/28	71.5-64.5/32	341-420/210	0.92-0.91	3490-3530
30	3	286TSC	1.15	208-230/460	91.7	74-67/33.5	85-77/38.5	400-489/245	0.92-0.91	3490-3540

Note that Grundfos ML motors are rated for 208-230/460 V.

ODP motors

Open Drip Proof, constant speed

WEG motors

HP	Ph	Frame	Service factor	Voltage [V]	Motor eff. η [%]	Full-load current $I_{1/1}$ [A]	Service-factor current [A]	Starting current I_{start} [A]	Power factor $\cos \phi_{1/1}$	Speed [rpm]
15	3	254TC	1.15	230/460	90.2	38.9-35.2/17.6	38.9-40.5/20.2	292-264/132	0.87	3545
	3	254TC	1.15	575	90.2	14.1	16.2	106	0.87	3545
20	3	256TC	1.15	230/460	91.0	52.6-47.6/23.8	52.6-54.7/27.4	316-286/143	0.87	3525
	3	256TC	1.15	575	91.0	19	21.9	114	0.87	3525
25	3	284TSC	1.25	230/460	91.7	64.4-58.2/29.1	64.4-72.8/36.4	425-384/192	0.87	3544
	3	284TSC	1.25	575	91.7	23.3	29.1	154	0.87	3544
30	3	284TSC	1.25	230/460	91.7	77.4-70.0/35	77.4-87.5/43.8	488-441/221	0.86	3550
	3	284TSC	1.25	575	91.7	28	35.0	176	0.86	3550
40	3	324TSC	1.25	230/460	92.4	104.0-93.7/46.8	104-117/58.5	634-572/285	0.87	3557
	3	324TSC	1.25	575	92.4	37.5	46.9	229	0.87	3557
50	3	324TSC	1.25	230/460	93.0	131-119/59.4	131-149/74.3	825-750/374	0.84	3560
	3	324TSC	1.25	575	93.0	47.5	59.4	299	0.85	3560
60	3	326TSC	1.25	230/460	93.6	157-142/71	157-178/88.8	989-895/447	0.85	3560
	3	326TSC	1.25	575	93.6	56.8	71.0	358	0.85	3560
75	3	365TSC	1.25	230/460	93.6	188-170/84.8	188-213/106	1241-1122/560	0.87	3555
	3	365TSC	1.25	575	93.6	67.8	84.8	447	0.87	3555
100	3	404TSD	1.25	460	93.6	115	144	782	0.87	3557
125	3	405TSD	1.25	460	94.1	136	170	925	0.88	3557
150	3	444TSD	1.15	460	94.1	169	194	1099	0.86	3570
200	3	444TSD	1.15	460	95.0	225	259	1463	0.88	3570
250	3	445TSD	1.15	460	95.0	278	320	1863	0.88	3570
300	3	445TSD	1.15	460	95.4	329	378	2139	0.88	3570

Note that motors listed at 230/460 V in the table are suitable for operation at 208 V.

10. Accessories

PJE couplings for CRN

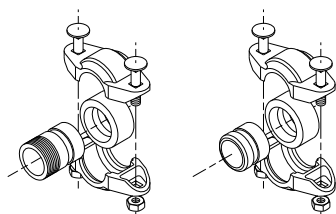
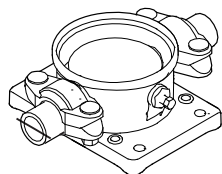

TM079035

TM003808

Materials in contact with the pumped liquid are made of stainless steel AISI 316 and rubber.

A set consists of two coupling halves (Victaulic® type 77), one gasket, one pipe stub (for welding or threaded), bolts and nuts.

Pump type	Pipe stub	Max. pressure [psi (bar)]	Pipe connection	Rubber parts	Number of coupling sets required
CRN 95	For welding	1000 (69)	4"	EPDM	2
CRN 95	For welding	1000 (69)	4"	FKM	2

11. Grundfos Product Center

Online search and sizing tool to help you make the right choice.

From the international view, you can select your specific country to view the product range available to you.

International view: <https://product-selection.grundfos.com>

All the information you need in one place

Performance curves, technical specifications, pictures, dimensional drawings, motor curves, wiring diagrams, spare parts, service kits, 3D drawings, documents, system parts. The Product Center displays any recent and saved items - including complete projects - right on the main page.



Downloads

On the product pages, you can download installation and operating instructions, data booklets, service instructions, etc., in PDF format.

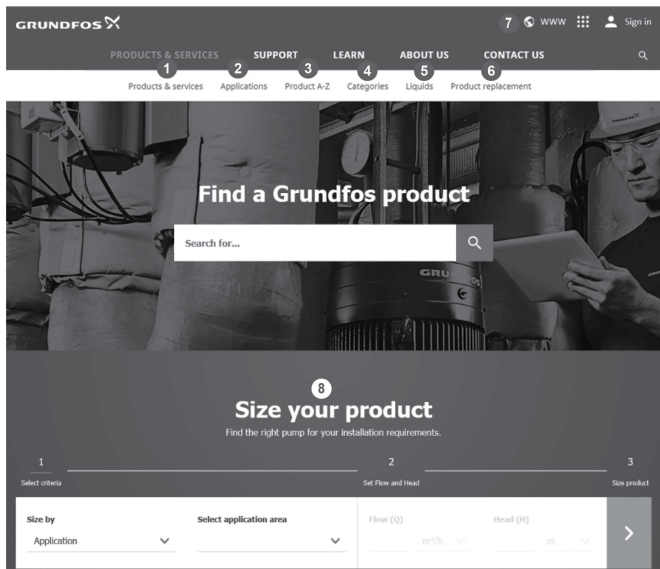

When you select your country, you will see the menus below. Note that some menus may not be available depending on the country.

Example: <https://product-selection.grundfos.com/us>

Pos.	Description
1	Products & services enables you to find products and documents by typing a product number or name into the search field.
2	Applications enables you to choose an application to see how Grundfos can help you design and optimize your system.
3	Products A-Z enables you to look through a list of all the Grundfos products.
4	Categories enables you to look for a product category.
5	Liquids enables you to find pumps designed for aggressive, flammable or other special liquids.
6	Product replacement enables you to find a suitable replacement.
7	WWW enables you to select the country, which changes the language, the available product range and the structure of the website.
8	Sizing enables you to size a product based on your application and operating conditions.

Grundfos GO Remote

Mobile solution for professionals on the GO!

Grundfos GO Remote is the mobile tool box for professional users on the go. It is the most comprehensive platform for mobile pump control and pump selection, including sizing, replacement and documentation. It offers intuitive, handheld assistance and access to Grundfos online tools, and it saves valuable time for reporting and data collection.

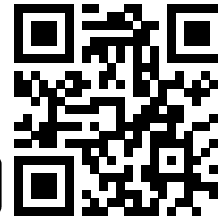
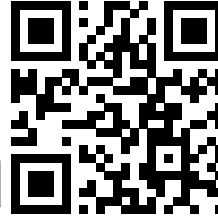

U.S.A.

Global Headquarters for WU
856 Koomey Road
Brookshire, Texas 77423 USA
Phone: +1-630-236-5500

GRUNDFOS CBS Inc.
902 Koomey Road
Brookshire, TX 77423 USA
Phone: 281-994-2700
Toll Free: 1-800-955-5847
Fax: 1-800-945-4777

GRUNDFOS Pumps Corporation
9300 Loiret Boulevard
Lenexa, Kansas 66219 USA
Tel.: +1 913 227 3400
Fax: +1 913 227 3500

Canada

GRUNDFOS Canada inc.
2941 Brighton Road
Oakville, Ontario
L6H 6C9
Tel.: +1-905 829 9533
Fax: +1-905 829 9512

Mexico

Bombas GRUNDFOS de México
S.A. de C.V.
Boulevard TLC No. 15
Parque industrial Stiva Aeropuerto
Apodaca, N.L. 66600
Tel.: +52-81-8144 4000
Fax: +52-81-8144 4010

Revision Info

Last revised on 04-2021

99407996 04.2023

ECM: 1364152

GRUNDFOS Holding A/S
Poul Due Jensens Vej 7
DK-8850 Bjerringbro
Tel: +45 87 50 14 00
www.grundfos.com

GRUNDFOS 