

VANTAGE SINGLE CARTRIDGE SEAL FEATURES

ANSI MULTI-SPRING AND WELDED METAL BELLOWS MECHANICAL SEAL

PRODUCT LINE FEATURES

- Simple cartridge seal installation
- Sleeve is isolated from process fluid
- 3/8" NPT flush connection allows for cooling and venting of seal.
- 1/4" NPT vent and drain connections provide differential sizing to minimize the potential of improper piping
- Non-sparking throttle bushing is positively retained to avoid pressure blow out, minimizing leakage in the event of seal failure.
- Vantage seal glands include flush, vent, and drain connections and a close-clearance, non-sparking throttle bushing to direct any leakage to the drain connection.
- Flush, vent, and drain connections available to be piped at multiple locations.
- Angled gland connections allow for easier pipe fitting.
- Setting clips provide positive axial and radial setting of the Vantage cartridge seal to ensure proper seal installation. The Vantage setting clips are easy to access for simple removal.
- Convertible gland design to accept over four (4) design configurations

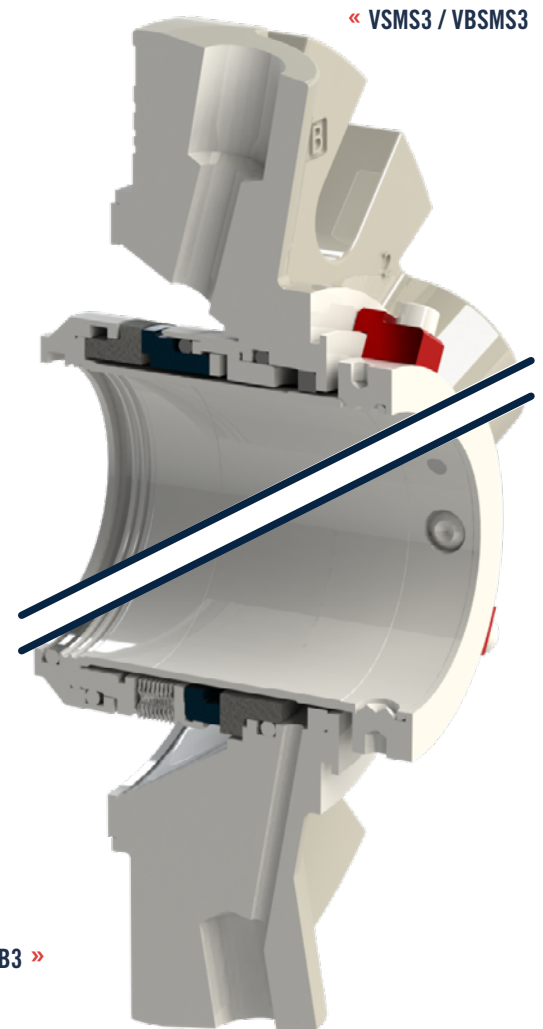

VRB3 / VBRB3

ANSI ROTATING WELDED METAL BELLOWS SINGLE CARTRIDGE MECHANICAL SEAL

FEATURES

- Rotating design uses centrifugal force for self-cleaning
- Uniform 360° transfer of torque to the rotating face
- Welded metal bellows replace the dynamic elastomer which can hang up the seal faces
- No springs to clog or break
- No fretting
- Only three (3) static elastomers – eliminate seal failures caused by dynamic O-ring “hang up” and offers cost savings when upgrading to Perfluorelastomers.

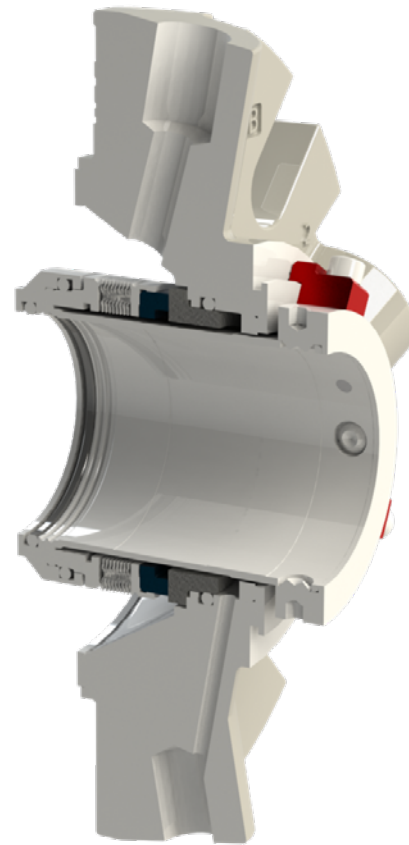

Materials of Construction

Rotating Seal Face	Carbon, Tungsten Carbide, Sintered Silicon Carbide
Stationary Seal Face	Sintered Silicon Carbide
Bellows	Hastelloy® C276
Metallurgy	316 SS
Elastomers	Viton®, Ethylene Propylene, Aflas®, Buna, Neoprene, Perfluorelastomer
Gland Gasket	Glass-Filled Teflon™
Throttle Bushing	Glass-Filled Teflon™

Operating Parameters

Temperature	400° F (200°C)
Pressure	300 PSI (20 Bar)
Speed	6000 FPM

* Maximum temperature/speed/pressure/runout indicates operating extremes independently and does not imply the seal will function at these extremes at the same time.

Registered Trademarks:

Viton® - Dupont Performance Elastomers; Aflas® - Asahi Glass Co.; Teflon® - E.I. Dupont de Nemours and Co; Hastelloy® - Haynes International, Inc.

VANTAGE SINGLE CARTRIDGE FEATURES

DESIGN FEATURES & BENEFITS

Setting Clips provide positive axial and radial setting of the Vantage cartridge seal to ensure proper seal installation. The Vantage setting clips are easy to access for simple removal.

Non-Sparking Throttle Bushing is positively retained to avoid pressure blow out, minimizing leakage in the event of seal failure.

Stationary Springs isolated from process fluids to minimize corrosion, clogging, and stress-related failures

3/8" NPT Flush Connection allows for cooling and venting of seal.

Dynamic Drive Ring eliminates primary face hang up and reduces face to pin fretting

Stationary Design for optimal face alignment.

Dynamic Elastomer moves on non-metallic, smooth surface eliminating fretting

Unique Flat Drive System Seal faces are driven by large surface area drive flats in retainers to reduce stress and face fracture common with drive pins

Sleeve is isolated from process fluid.

VSMS3/VBSMS3

VRB3/VBRB3

• No fretting • No springs to clog or break

• Uniform 360° transfer of torque to the rotating face.

• **Angled Gland Connections** allow for easier pipe fitting.

• **1/4" NPT Vent and Drain Connections** provide differential sizing to minimize the potential of improper piping.

• **Welded Metal Bellows** replace the dynamic elastomer which can hang up the seal faces.

• **Rotating Design** uses centrifugal force for self-cleaning.

• **Only Three (3) Static Elastomers** eliminate seal failures caused by dynamic O-ring "hang up" and offers cost savings when upgrading to Perfluorelastomers.