

## POWERGLAND – SPRING ASSISTED GLAND

### Constant Tension, Minimal Maintenance

PowerGland can drastically reduce your operational interventions on packed rotating equipment by addressing critical issues: inconsistent gland pressure, frequent repacks, and high manpower requirements. Its spring-assisted design and high-quality alloys provide consistent gland tension on packing, significantly reduce the need for repacks, and minimize manpower requirements, enhancing operational efficiency and safety.

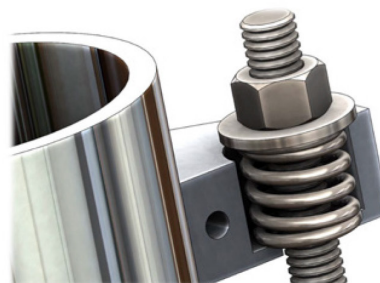
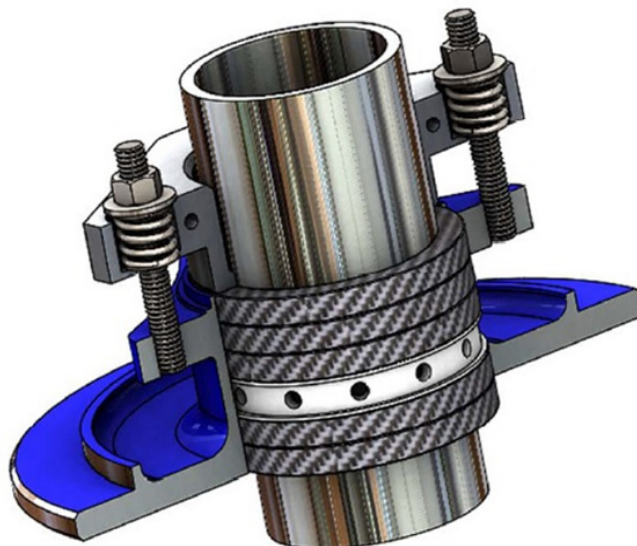

### FEATURES

- Standard OEM split gland design
- Broad range of alloy options for chemical compatibility
- Designed to encapsulate compression springs
- Fits rotating equipment without modification to existing equipment

### BENEFITS

- Keeps constant gland pressure on packing
- Reduces the need for repacks
- Reduces manpower requirements
- Reduces packing failure from vibration and process interruptions
- Safety: eliminates the need for repacks in hazardous environments

## THE POWERGLAND EXCELS IN SEALING THESE APPLICATIONS:

- **Pulp & Paper**

Raw Water, Cooling Water, Chemical Handling, Thick Stock (High Consistency), Medium Consistency Stock, Green Liquor, White Liquor, Black Liquor, Waste Water Treatment, Power House

- **Alumina Refining**

Bauxite Grinding Pumps, Caustic Cleaning Preparation, Digester Feed, Desilicator Discharge Pump, Seed Filtrate Pump, Coarse Seed Filter Feed Pumps, Seed Charge

- **Gold Mining**

Carbon In Leach Tails, Concentrate Transfer, Cyanide Transfer, Conditioning Tank feed, Decant Water, Saline Water, Tails Thickener feed

- **Hard Rock Mining**

Dewatering and pumping stations

- **Flue Gas Desulfurization (FGD)**

Limestone Recirculation/Scrubber Feed, Ash Pumps, Calcium Sulfate Slurry, Gypsum Slurry, Filtrate Return

- **Ore Mining**

Limes Pump, Concentrator Feed, Tailings/Tailings Booster pumps, Mineral sand slurry, Mineral sand concentrate

- **Synthetic Rutile Plant**

Slurry Transfer Pumps, Acidic Slurry Transfer Pumps

- **Pigment Plant**

Finished Slurry pump, Neutralization feed pump, Chlorine Compressors (GARO)

- **Industrial Processes**

Sugar beets, cement fiber board, diatomaceous earth

- **Aggregates**

Fines recovery, thickener/clarifier underflow, belt-press feed

- **Coal Prep/Washing**

Thickener Underflow, Thickener Overflow