

## VANTAGE TANDEM SOLIDS EXCLUDING (VTSE) SLURRY SEAL

### Designed For Small Bore Stuffing Boxes

The Style VTSE has been designed specifically for sealing abrasive and corrosive applications in smaller cross-section stuffing boxes such as ANSI Standard Bore and others.

Not only does the Style VTSE excel in sealing in harsh operations with high-solids slurries/pastes and aggressive chemicals, but it also does so in a way that uses very little cooling water or barrier fluid.

### WHY THE STYLE VTSE?

- Simple installation with insertion of O-ring mounted inboard mating ring at the bottom of the stuffing box, followed by a fully integrated cartridge outboard assembly.
- A shrink-fit inboard rotating face arrangement evenly distributes the torque, eliminating the need for failure prone drive pins.
- Common misalignment issues solved with inboard primary face assembly captured in the outboard cartridge.
- The close-clearance inboard mating ring face inhibits slurry ingress to the seal, resulting in longer life in service.
- Limited number of components are wetted, reducing the need for specialty metallurgy.

### EQUIPMENT *INCLUDING*

- Goulds (or equivalent)
- Durco (or equivalent)
- DiscFlo

### OPERATING PARAMETERS

<b>Working Pressure</b>	300psi (20.7 bar)
<b>Max Temperature</b>	400°F (205°C)

\*Materials customizable to application.

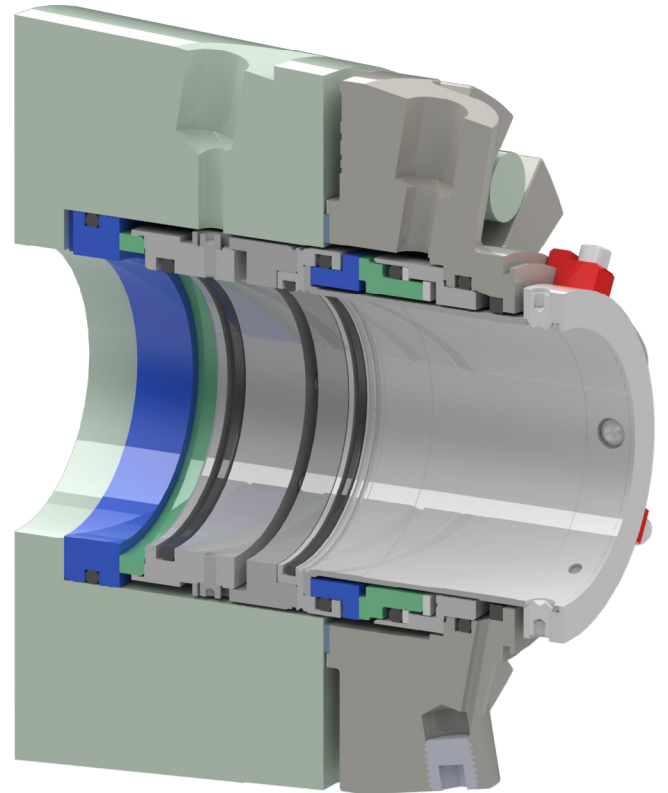

**DESIGN FEATURES & BENEFITS**

**INTEGRATED STUFFING BOX**

The stuffing box becomes an integral part of the seal, providing containment and an outlet for barrier fluid.

**SLURRY-RESISTANT MATERIALS**

Slurry-rated face materials on large inboard stationary seat and primary inboard seal face.

**INNOVATIVE 360° TORSIONAL DRIVE**

The shrink-fit inboard rotating face eliminates the need for drive-pins, and transmits the torque uniformly.

**OUR ADVANTAGE**

Cartridge-style mount allows for simple two component installation without the need to find anti-rotation pinholes on fit-up.

**BARRIER FLUID OUTLET**

**BARRIER FLUID INLET**

**PROTECTED SPRINGS**

All springs are isolated from the process liquid, decreasing the risk of clogging and wear.

**PROVEN VANTAGE DESIGN**

Outboard components are built on Flexaseal's field-proven Vantage platform.

**ENHANCED COOLING CIRCULATION**

Integral pumping ring circulates cooling barrier fluid throughout seal and stuffing box.

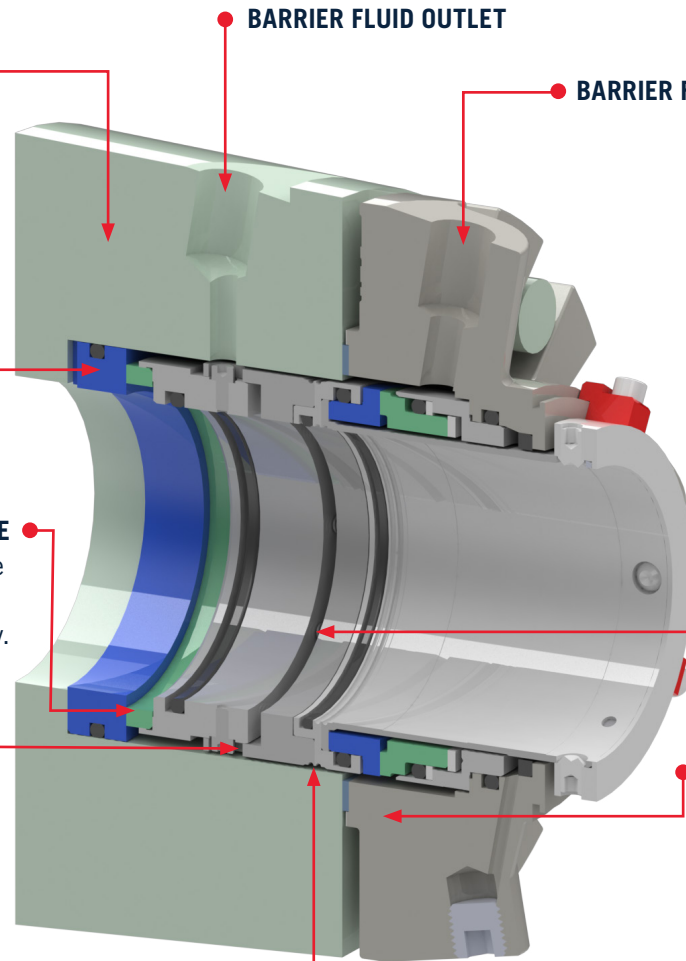

Optional addition of Flex-A-Flo device to Barrier Fluid Outlet port can reduce water flush rates by up to 90% on Plan 54 flushes run from pressurized plant water.