

## HEAVY DUTY FLUSHLESS SLURRY SEAL

### *RELIABILITY AND SAVINGS FOR THE SLURRY PUMP MARKET*

The Rock Killer Crusher (RKC) Series seals are built for the harshest applications in slurry pumping, which can be found in mining, mineral processing, flue gas desulfurization and many others.

The RKCS Series is a single cartridge seal designed with ease of maintenance in mind, and it is meant to be operated with zero external flushing.

### WHY THE RKCS?

- Ease of fitment, simple maintenance cartridge design with popular slurry pump conversion kits available
- Abrasion and corrosion resistant materials promote longevity in service
- Seal design together with pump features coordinate to allow single-face flushless sealing of slurries up to 60% solids by weight.
- Stationary face mutlispring design has springs isolated and far from pumped media
- Large and open inner seal chamber that self-evacuates and doesn't pack in and hold heat.
- For special circumstances, outboard lip seal installed and Plan 62 grease or water quench provide lubrication to the seal faces during dry running pump cycles.

### EQUIPMENT *INCLUDING*

- Weir Slurry Group -Warman, Schurco
- ASH, MC & Hazleton
- Flowserve - Worthington
- KSB / GIW Minerals - LCC
- Any solids handling pump
- Toyo
- Metso
- Ekato

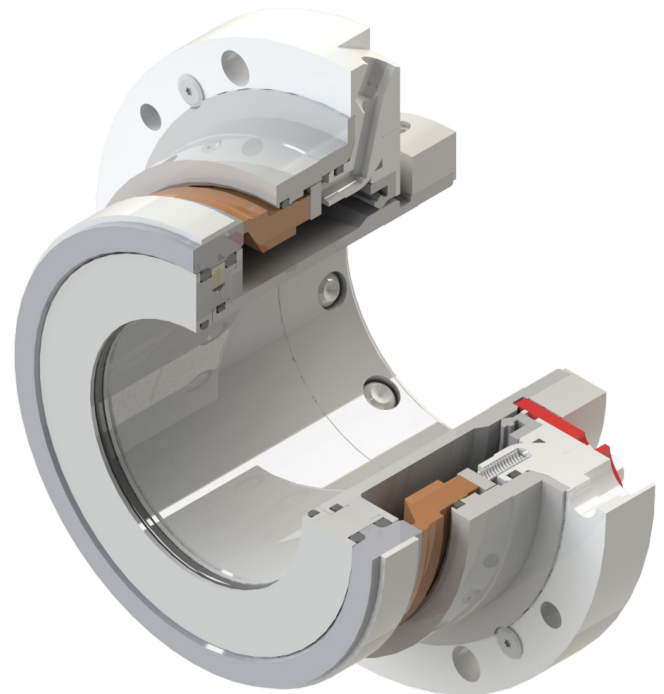

**FLUSHLESS SEALING FOR SLURRY APPLICATIONS**

## THE RKCS EXCELS IN SEALING THESE APPLICATIONS:

- **Alumina Refining**  
Bauxite Grinding Pumps, Caustic Cleaning Preparation, Digester Feed, Desilicator Discharge Pump, Seed Filtrate Pump, Coarse Seed Filter Feed Pumps, Seed Charge
- **Gold Mining**  
Carbon In Leach Tails, Concentrate Transfer, Cyanide Transfer, Conditioning Tank feed, Decant Water, Saline Water, Tails Thickener feed
- **Hard Rock Mining**  
Dewatering and pumping stations
- **Coal Prep/Washing**  
Thickener Underflow, Thickener Overflow
- **Flue Gas Desulfurization (FGD)**  
Limestone Recirculation/Scrubber Feed, Ash Pumps, Calcium Sulfate Slurry, Gypsum Slurry, Filtrate Return
- **Mineral Sands**  
  - Ore Mining**  
Limes Pump, Concentrator Feed, Tailings/Tailings Booster pumps, Mineral sand slurry, Mineral sand concentrate
  - Synthetic Rutile Plant** Slurry Transfer Pumps, Acidic Slurry Transfer Pumps
  - Pigment Plant** Finished Slurry pump, Neutralization feed pump, Chlorine Compressors (GARO)
- **Industrial Processes**  
Sugar beets, cement fiber board, diatomaceous earth
- **Aggregates**  
Fines recovery, thickener/clarifier underflow, belt-press feed

### MATERIALS OF CONSTRUCTION

<b>Inboard Faces</b>	Ni-B Tungsten Carbide, Sintered Silicon Carbide, Graphite Loaded Silicon
<b>Outboard Faces</b>	Antimony Impregnated Carbon, Silicon Carbide
<b>Elastomers</b>	FKM standard Other materials available by request
<b>Springs</b>	Alloy C276
<b>Metallurgy</b>	316 SS with Alloy 255 or High Chromium Iron Wetted

Other materials available by request

### OPERATING PARAMETERS

<b>Shaft Sizes</b>	Up to 20.0" (508 mm)
<b>Working Pressure</b>	500 psi (34.5 bar)
<b>Temperature</b>	-4° to 425°F (-20° to 218°C)
<b>Speed</b>	Up to 3600 fpm (18.3 m/s)
<b>Viscosity</b>	Up to 2500 cP (2.5 Pa•s)

DESIGN FEATURES & BENEFITS

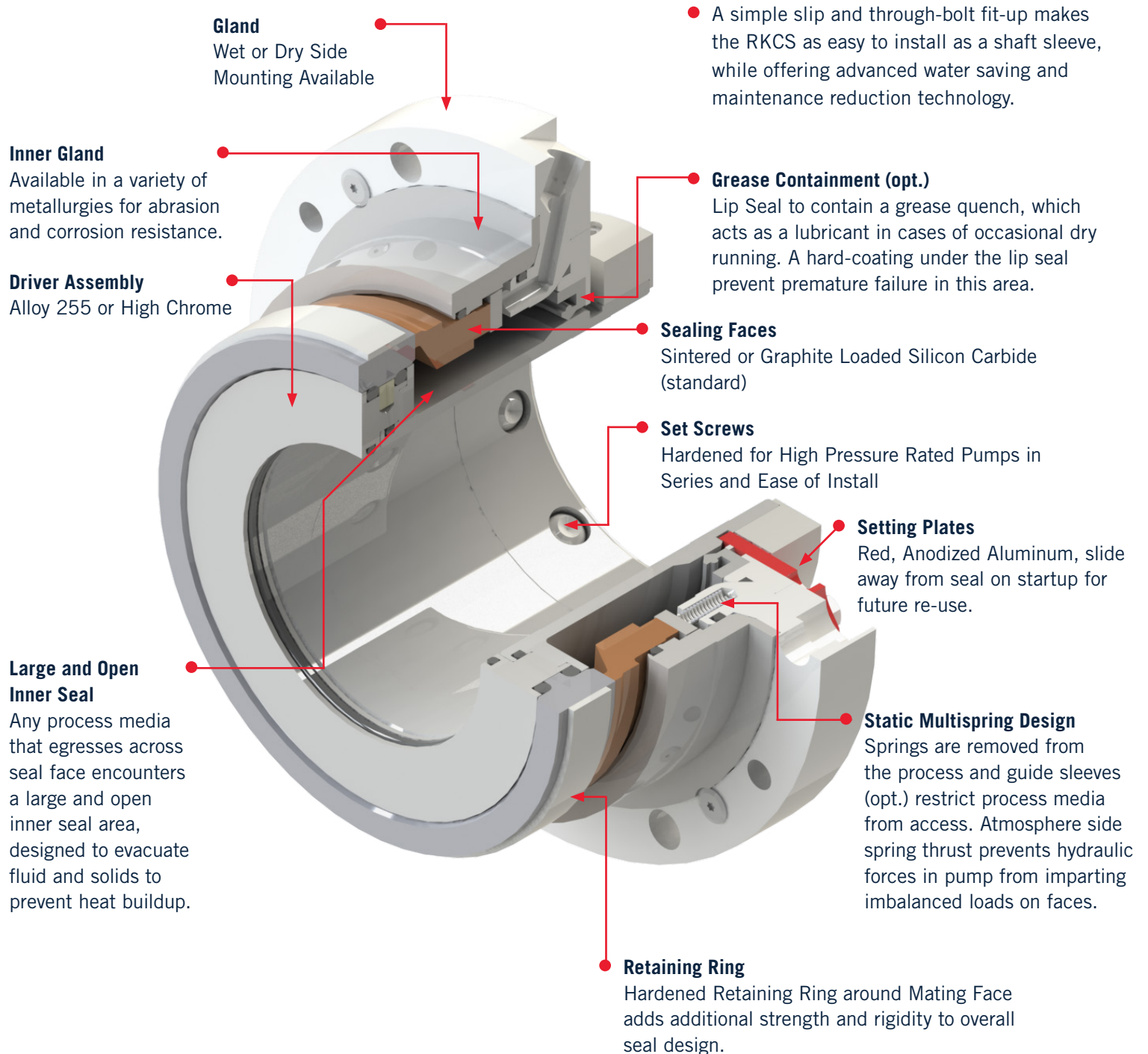

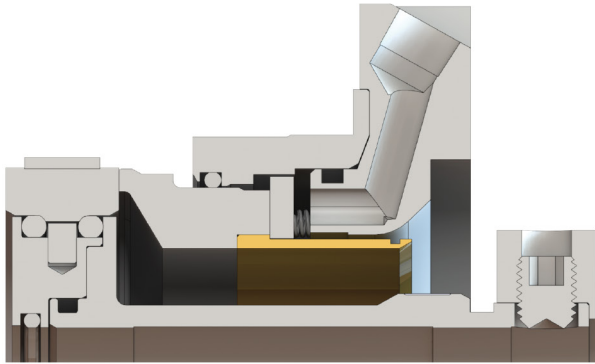

### RKCS VERSION A

**Integral Spring Shield** is manufactured from a flexible and durable material to effectively shield the springs from debris and slurry during operation. Compatible with API 682 Plan 32. **Flush connection optional.**

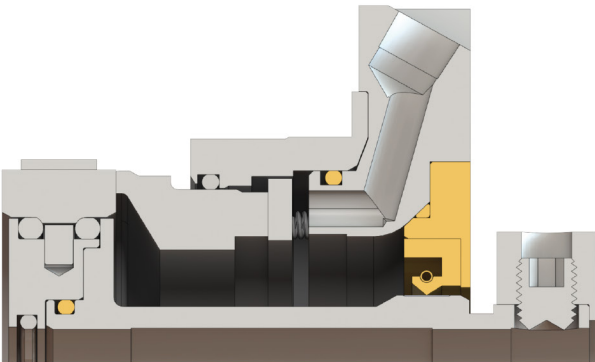

### RKCS VERSION B

**(For grease-filled operation)**

Addition of **bolt-on lip seal assembly and two (2) additional O-rings**. Compatible with API 682 Plan 32.

**Flush connection optional.**

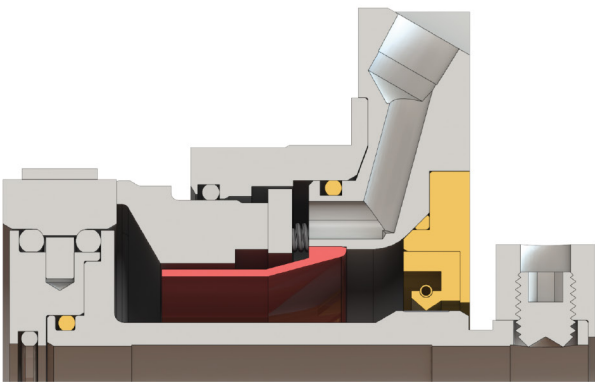

### RKCS VERSION C

**(Quench operation)**

**Fluid Guide Sleeve** added to Version B to support the effective removal of debris during quench operation. Compatible with API 682 Plan 32.

**Flush connection optional.**

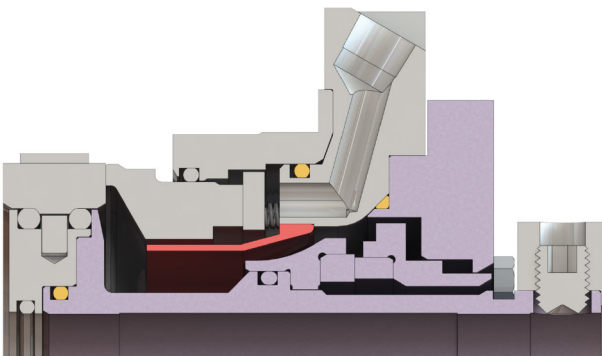

### RKCD (DUAL SEAL)

A **dual seal option** designed for the most rigorous slurry processes. In addition to Version C's Fluid Guide Sleeve, this option is engineered for optimum service when paired with either an API 682 Plan 53A buffer or API 682 Plan 54 barrier fluid seal support system.

Designs available for both dry end and wet end mounting  
All versions available with a clamped collar design for hardened pump shafts  
Adapter plates for dry end mounting and shaft sleeves available for all common pump models