

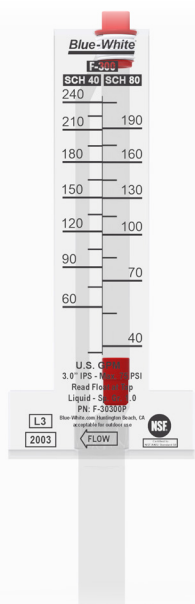

F-300

Variable Area Flow Meter



Features

- > Easy to read dual scale (SCH 40 / SCH 80)
- > Reads Horizontal, upwards or downwards flow
- > Acceptable for outdoor installations
- > Pitot Tube design makes it easy to install on existing pipe
- > One-piece, machined acrylic meter body
- > Standard Horizontal Units NSF 50 listed
- > Optional Flow Switch available

Video link:



Highlights

Flow range

5.0 - 2,200 GPM (SCH 40)
4.0 - 1,950 GPM (SCH 80)

Pressures up to

50 PSI
(3.4 bar)

Max. fluid temp.

190 °F
88 °C

Body material

Acrylic

Pipe sizes

1" to 8"

Warranty

1 Year



Pipe Requirements	IPS inch pipe size (ASTM-D-1785)
Maximum Working Pressure	50 PSI (3.4 bar) at 70 °F (21 °C) F-300 Units 75 PSI (5.2 bar) at 70 °F (21 °C) U/D-300 Units
Fluid Temperature Range	0° to 190 °F / -18 to 88 °C @ 0 PSI
Ambient Temp Range	0° to 110 °F / -18 to 43 °C
Full Scale Accuracy	1", 1.25", 1.5" and 2" pipe size: 5% 2.5", 3", 4", 6", and 8" pipe size: 10%
Calibration Fluid	Water, specific gravity 1.0
Approximate Shipping Weight	1" - 4" units: 1 lb (.45kg) 6" - 8" units: 2 lb (.91kg)

Dimensions

F-300 Series (NSF 50 Listed)

Pipe Size	A	B
1"	6"	2-7/16"
1-1/4"	6"	2-7/16"
1-1/2"	6"	2-7/16"
2"	6"	2-7/16"
2-1/2"	6"	2-7/16"
3"	6"	2-7/16"
4"	6"	2-7/16"
6"	7-1/2"	2-7/16"
8"	7-1/2"	2-7/16"

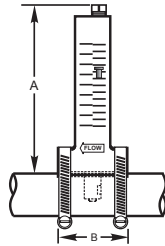

U/D-300 Series

Pipe Size	A	B
1-1/2"	6"	1-9/16"
2"	6"	1-9/16"

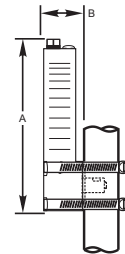

Maximum Temperature vs. Pressure

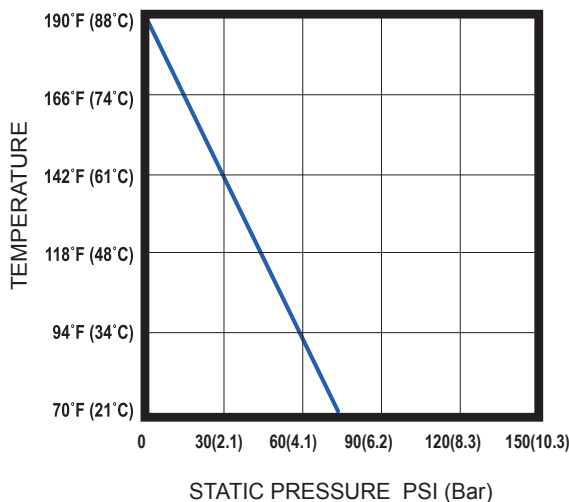

Wetted Components:

Meter Body	Acrylic
Float	PVDF
Gasket	Neoprene
Pipe Clamp	316SS

Output Specifications

Models for Mounting on Horizontal Pipe
Models for U.S. IPS Sch40 & 80 Pipe
(ASTM 1785)

Model	Pipe size	Sch40	Sch80
F-30100P	1"	5 to 35	4 to 26
F-30125P	1-1/4"	9 to 50	8 to 40
F-30150P	1-1/2"	10 to 70	10 to 60
F-30200P	2"	20 to 120	18 to 100
F-30250P	2-1/2"	29 to 150	25 to 130
F-30300P	3"	45 to 240	40 to 215
F-30400P	4"	75 to 420	70 to 375
F-30600P	6"	170 to 1100	160 to 1000
F-30800P	8"	300 to 2200	275 to 1950

Models for Mounting on Vertical Pipe
Models for U.S. IPS Sch40 & 80 Pipe
(ASTM 1785)

Model	Pipe size	Sch40	Sch80	Flow direction
U-30150P	1-1/2"	10 to 60	10 to 50	UP
D-30150P	1-1/2"	10 to 60	10 to 50	DOWN
U-30200P	2"	20 to 110	20 to 100	UP
D-30200P	2"	20 to 110	20 to 100	DOWN

Installations Requirements

The meter's accuracy is affected by disturbances such as pumps, elbows, tees, valves, etc., in the flow stream. Install the meter in a straight run of pipe as far as possible from disturbances.

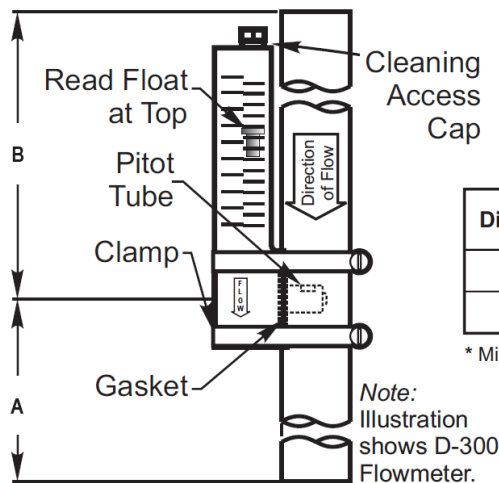

Dimension	Pipe Requirement
A	Outlet pipe length = 2 x Pipe I.D.*
B	Inlet pipe length = 5 x Pipe I.D.*

* Minimum acceptable dimensions.

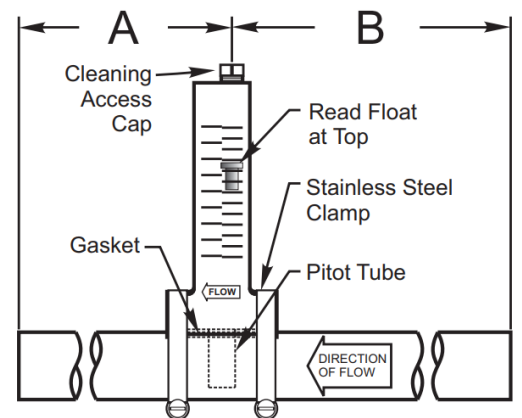

Model Number Matrix

F-300 Model Number

F	Standard Flow Meter (Horizontal Flow) (NSF 50 Listed)
U	Flow Meter (Upwards Flow 1.5" and 2.0" only)
D	Flow Meter (Downwards Flow 1.5" and 2.0" only)

Series

30	F-300 Acrylic Body
-----------	--------------------

GPM Scale SCH 40 / SCH 80

100	1.0" Pipe, 5 - 35 GPM sch 40 (4 - 26 GPM sch 80)
125	1.25" Pipe, 9 - 50 GPM sch 40 (8 - 40 GPM sch 80)
150	1.50" Pipe, 10 - 70 GPM sch 40 (10 - 60 GPM sch 80)
150	UP/DOWN 1.5" Pipe, 10 - 60 GPM sch 40 (10 - 50 GPM sch 80)
200	2.0" Pipe, 20 - 120 GPM sch 40 (18 - 100 GPM sch 80)
200	UP/DOWN 2.0" Pipe, 20 - 110 GPM sch 40 (20 - 100 GPM sch 80)
250	2.5" Pipe, 29 - 150 GPM sch 40 (25 - 130 GPM sch 80)
300	3.0" Pipe, 45 - 240 GPM sch 40 (40 - 205 GPM sch 80)
400	4.0" Pipe, 75 - 420 GPM sch 40 (70 - 375 GPM sch 80)
600	6.0" Pipe, 170 - 1100 GPM sch 40 (160 - 1000 GPM sch 80)
800	8.0" Pipe, 300 - 2200 GPM sch 40 (275 - 1950 GPM sch 80)

F	-	30	100	P	Sample Model Number
----------	----------	-----------	------------	----------	----------------------------

Accessories



1.0"P - 1.25"P ONLY



1.5"P - 4.0"P ONLY