

CALL TOLL FREE 877-742-2878 FOR SALES AND SUPPORT

Return to BurtProcess.com

F-1000

INSTRUCTION MANUAL



Blue-White[®]

5300 Business Drive
Huntington Beach, CA 92649
USA

Phone: 714-893-8529 **FAX:** 714-894-9492

E mail: sales@blue-white.com or customerservice@blue-white.com

Website: www.blue-white.com

TABLE OF CONTENTS

<u>SECTION</u>	<u>HEADING</u>	<u>PAGE</u>
1.....	Introduction.....	2
2.....	Specifications.....	3
3.....	Features.....	4
4.....	How to install the meter.....	5
4.1.....	Mounting location.....	5
4.2.....	Pipe Flow Stream Requirements.....	6
4.3.....	How to install Your Saddle Fitting.....	8
4.3.1.....	Drill the Mounting Hole.....	9
4.3.2.....	Install the Saddle.....	9
4.3.3.....	Check the Saddle Alignment.....	9
4.3.4.....	Install the Sensor.....	10
4.4.....	Installing the Molded In-Line Fitting (MI).....	10
4.5.....	How to Install Molded PVC Tee Fitting.....	11
5.....	How to Operate the meter.....	12
6.....	Flow Ranges.....	9 - 10
7.....	Maintenance.....	15
8.....	Troubleshooting.....	14
9.....	Replacement Parts List.....	16

1.0 INTRODUCTION TO THE F-1000

Congratulations on purchasing the F-1000 electronic flow meter. The F-1000 is designed to measure the flow of a fluid in a pipe. The meter is factory calibrated to any engineering units and displays the rate of flow or the total of flow on a 6 digit LCD display. Two AAA batteries power the unit for up to one year. There are three models are available:

F-1000-RB is a rate meter - designed to measure and display the rate of flow.

F-1000-TB is a totalizer meter - designed to measure and display the total flow.

F-1000-RT is a rate/totalizer meter - designed to measure and display both the rate of flow and the total flow.

2.0 SPECIFICATIONS

Maximum Working Pressure*	300 psig / 20.7 bar
Maximum Fluid Temperature*	200° F / 93.3° C - Saddle and sensor only 200° F / 93.3° C - When mounted on polypropylene inline units. 140° F / 60° C - When mounted on molded PVC tee units or PVC pipe.
Ambient Temperature Range	32° to 110° F / 0° to 43° C
Enclosure	NEMA 4X (acceptable for outdoor use) NOTE: Protect the LCD display from direct sunlight.
Accuracy	+/-2% of full scale rate reading
Repeatability	+/-1% of full scale rate reading
Power Requirements	Two standard AAA alkaline batteries (included)
Battery Life Expectancy	1 year minimum

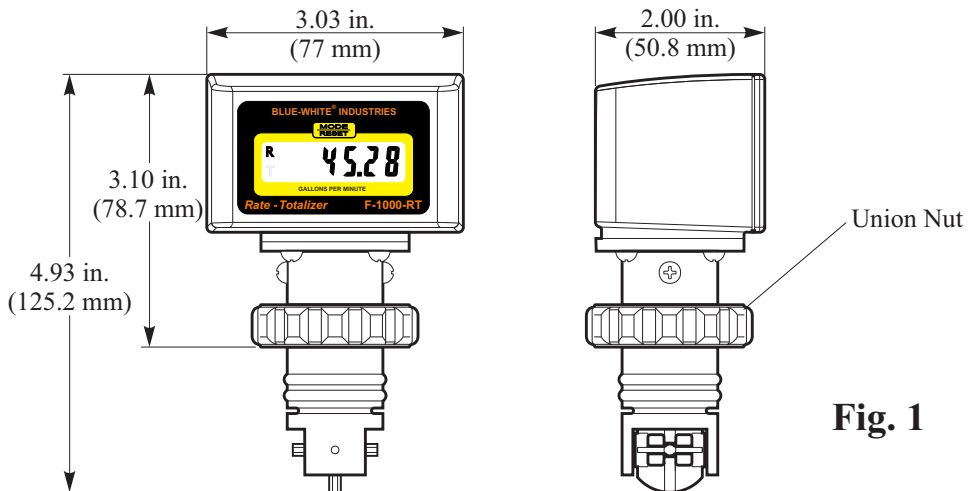

Fig. 1

3. FEATURES

- Easy to read .35" high, six digit LCD display
- Installs quickly on existing pipe
- Factory calibrated - nothing to program
- Minimal maintenance required
- No pressure drop
- Weather resistant enclosure
- Corrosion resistant PVDF sensor, ABS enclosure
- High accuracy
- Large calibrated flow range

*Temperature vs. Pressure

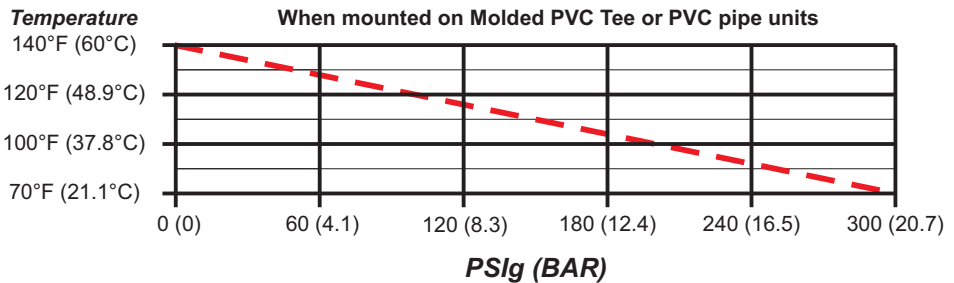
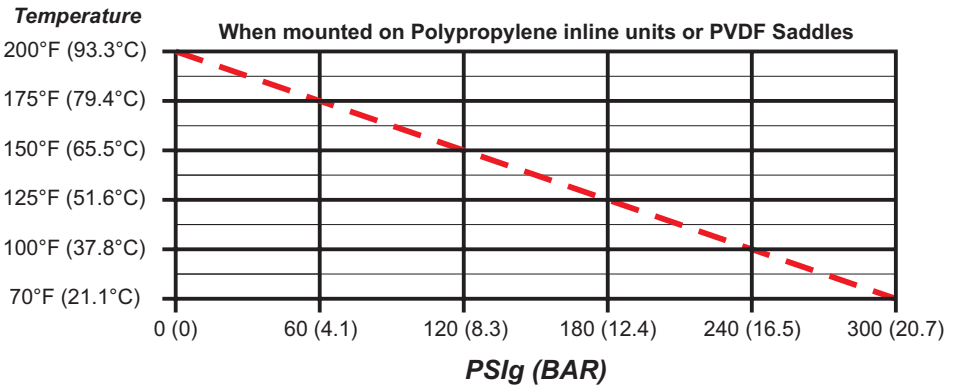

Fig. 2

*Pressure and temperature limits are inversely proportional.

4.0 HOW TO INSTALL THE F-1000

4.1 MOUNTING LOCATION

Note: All diagrams are strictly for guideline purposes only. Always consult an expert before installing the F-1000 on specialized systems.

Note: The F-1000 should be serviced by qualified persons only.

Although the F-1000 is designed to withstand outdoor conditions, a cool, dry location where the unit can be easily serviced is recommended. The life of the LCD display will be severely reduced when installed in direct sunlight. Do not install the meter so that the LCD is in direct sunlight.

- The F-1000 can be mounted on horizontal or vertical runs of pipe (see figure 4, 5 and 6). Mounting anywhere around the diameter of vertical pipe is acceptable, however, the pipe must be completely full of water at all times. Back pressure is essential on downward flows.
- The F-1000 accuracy is affected by disturbances such as pumps, elbows, tees, valves in the flow stream. Install the meter in a straight run of pipe as far as possible from any disturbances. The distance required for accuracy will depend on the type of disturbance.

Type Of Disturbance	Minimum Inlet Pipe Length	Minimum Outlet Pipe Length
Flange	10 X Pipe I.D.	5 X Pipe I.D.
Reducer	15 X Pipe I.D.	5 X Pipe I.D.
90 Elbow	20 X Pipe I.D.	5 X Pipe I.D.
Two 90 Elbow - 1 Direction	25 X Pipe I.D.	5 X Pipe I.D.
Two 90 Elbows - 2 Directions	40 X Pipe I.D.	5 X Pipe I.D.
Pump or Gate ValvesValves	50 X Pipe I.D.	5 X Pipe I.D.

- The pipe must be completely full at all times. Air bubbles or air pockets in the flow stream will adversely affect the reading. A small amount of back pressure is recommended in horizontal runs of pipe.
- The F-1000 is powered by two AAA batteries. Life expectancy is one year minimum.

4.2 PIPE FLOW STREAM REQUIREMENTS

- The F-1000 accuracy is based on steady, undisturbed flow with a fully developed turbulent flow profile. Pulsating, swirling and other disruptions in the flow stream will effect the meter's accuracy.
- The F-1000 is factory calibrated to $\pm 2\%$ of full scale rate reading. When measuring total flow, accumulated error over time must be considered. Accuracy is based on laboratory testing of nominal pipe dimensions. Your actual accuracy will vary based on your actual pipe I.D. And other installation factors.
- There are two basic types of flow profiles; turbulent and laminar (see figure 3). Turbulent flow exists when the speed of the fluid flowing in the pipe is nearly constant across the entire width of the pipe. This is typical of low viscosity fluids; like water, flowing at high velocity. Laminar flow exists when the speed of the fluid flowing in the center of the pipe is greater than the speed of the fluid at the outer edge near the pipe wall. This is typical of high viscosity fluids flowing at low velocity. Because the F-1000 is measuring the fluid near the pipe wall only (especially in larger pipe sizes), a constant flow velocity across the flow stream is required.

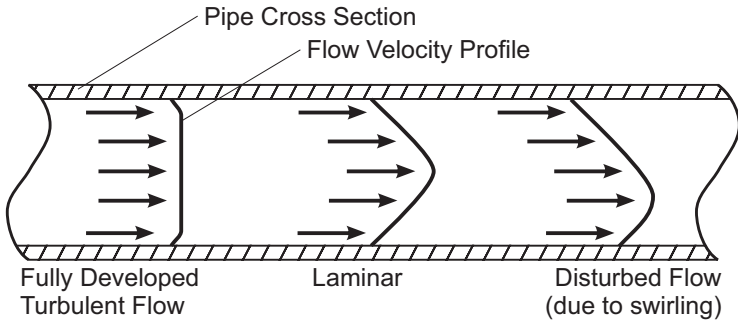

To determine which type of flow exists in your installation, the following is required:

Flow rate of the fluid in GPM - Q

Specific gravity of the fluid - G

Pipe inside diameter in inches - D

Fluid viscosity in centepoise - V

Use the following equation to determine the REYNOLDS NUMBER:

$$\text{REYNOLDS NUMBER} = \frac{3160 \times Q \times G}{D \times V}$$

Flow conditions with a Reynolds Number greater than 4000 is fully developed turbulent flow. A Reynolds Number less than 2000 is laminar flow. The F-1000 requires a Reynolds number greater than 4000 to maintain accuracy.

Vertical Mount

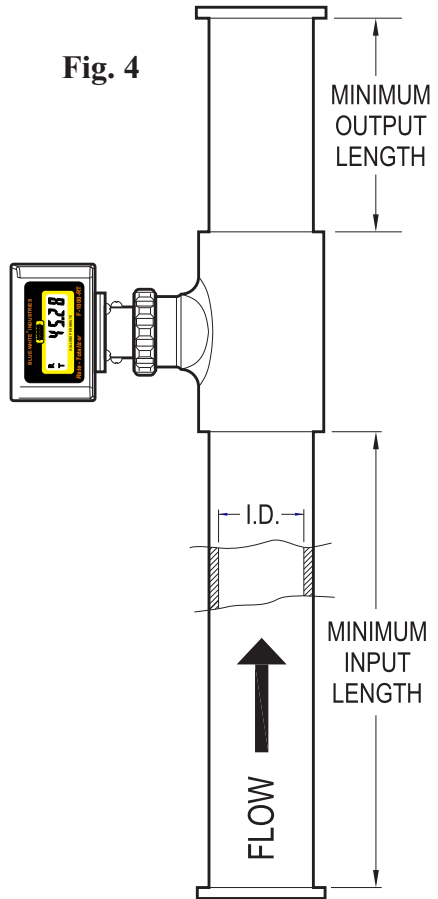

Horizontal Mount

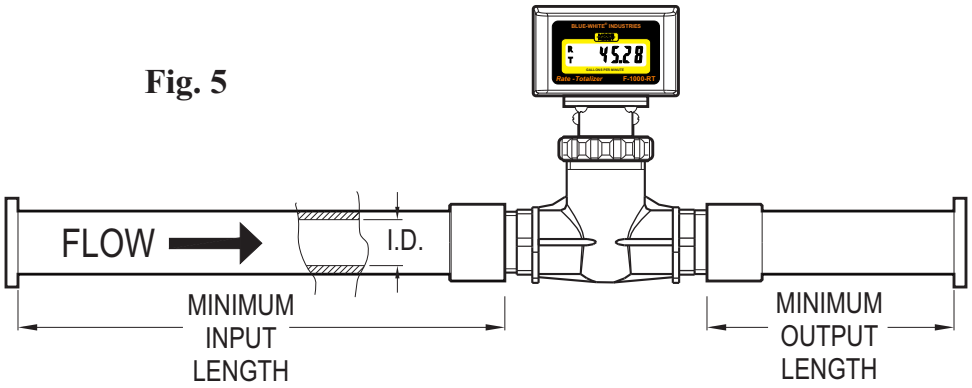

4.3 HOW TO INSTALL YOUR F-1000 SADDLE FITTING

The F-1000 saddle is designed to mount on smooth schedule 40 IPS pipe, schedule 80 IPS pipe (ASTM-D-1785) , PN10 metric pipe or PN16 metric pipe (DIN 8062). The outside of the pipe must be clean, smooth and free of surface imperfections. The outside diameter must be as specified to ensure a leak free installation. The inside diameter must be as specified to ensure meter accuracy.

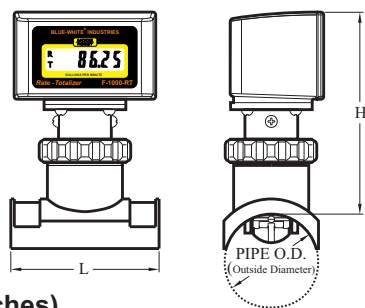

Fig. 7

I.P.S. Pipe Sizes (in inches)

(ASTM-D-1785)

Nominal Pipe Size	Length	Height	Schedule 40		Schedule 80	
			Outside Diameter	Inside Diameter	Outside Diameter	Inside Diameter
1-1/2"	3-3/16"	4-5/16"	1.900	1.610	1.900	1.500
2"	3-3/16"	4-5/16"	2.375	2.067	2.375	1.939
2.5"	3-3/16"	4-5/16"	2.500	2.469	2.500	2.323
3"	3-3/16"	4-5/16"	3.500	3.068	3.500	2.900
4"	3-3/16"	4-5/16"	4.500	4.026	4.500	3.826
6"	3-3/16"	4-1/4"	6.625	6.065	6.625	5.761
8"	3-3/16"	4-1/4"	8.625	7.981	8.625	7.625
10"	4-1/2"	4-1/4"	10.750	10.020	10.750	9.564
12"	4-1/2"	4-1/4"	12.750	11.938	12.750	11.376

Metric Pipe Sizes (in millimeters)

(DIN 8062)

Nominal Pipe Size	Length	Height	Pn10		Pn16	
			Outside Diameter	Inside Diameter	Outside Diameter	Inside Diameter
50 mm	81	110	50.0	45.2	50.0	42.6
63 mm	81	110	63.0	57.0	63.0	53.6
75 mm	81	110	75.0	67.8	75.0	63.8
90 mm	81	110	90.0	81.4	90.0	76.6
110 mm	81	110	110.0	99.4	110.0	93.6
160 mm	81	108	160.0	144.6	160.0	136.2
200 mm	81	108	200.0	180.8	200.0	170.2
250 mm	114	108	250.0	226.2	N/A	N/A
315 mm	114	108	315.0	285.0	N/A	N/A

4.3.1 DRILL THE MOUNTING HOLE

- Select an area on the pipe as outlined in section 4.1. Be sure the surface area of the pipe is clean and smooth.
- Drill a 1-1/8" diameter hole through the pipe wall. The F-1000 meter can be installed up to 45 degrees from the top of the pipe. A hole saw kit is available from the factory, order part number 20000-062.
- Clean all burrs from inside and outside the hole. Use fine sandpaper (440 grit) if necessary.

4.3.2 INSTALL THE SADDLE

- Insert the alignment tool through the top of the saddle. Proper alignment is critical! Slide the large O-ring over the bottom of the alignment tool and into the groove on the underside of the saddle.
- With the alignment tool and O-ring in place, position the saddle over the drilled hole. Insert the alignment tool into the hole seating the saddle. Be sure the O-ring is properly seated in the O-ring groove. Place the pipe clamps around the pipe and into the slots on the saddle. Tighten the clamps in an alternating method.

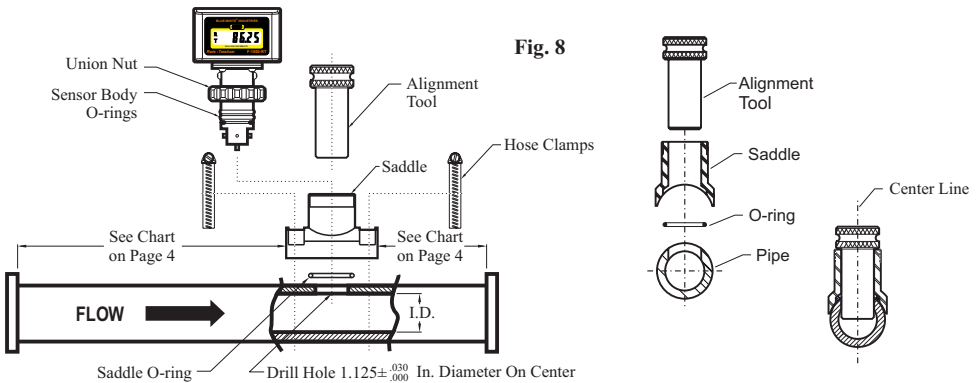

4.3.3 CHECK THE SADDLE ALIGNMENT

- Pull the alignment tool out of the saddle. (If the tool is not easily removed, slightly loosen the clamps) Inspect the hole. The saddle must be mounted directly over the hole. Adjust the saddle alignment until the alignment tool slides freely in and out of the saddle.
- Be certain the O-ring is properly seated and visible in the groove around the hole.
- Tighten the clamps.

4.3.4 INSTALL THE F-1000 SENSOR

- Be sure two O-rings are located on the sensor body. The O-rings have been lubricated at the factory with silicone oil.
- Push the sensor assembly into the saddle with a twisting motion. The notch on the sensor body must fit into the slot on the saddle. Be sure the sensor is fully inserted into the saddle.
- **HAND TIGHTEN** the union nut.

4.4 INSTALLING THE MOLDED IN-LINE FITTING (MI)

All molded in-line (MI) fittings have male American National Standard Taper Pipe Threads (MPT).

- Select an area on the pipe as outlined in section 4.1.
- Install the F-1000 as you would any other plastic pipe fitting. Be sure the inlet and outlet fittings are aligned properly. Improper alignment of the fittings will put stress on the adapter connections and may cause leaking or fitting damage. Do not over tighten the fittings. Use PTFE tape sealant only on the adapter threads.
- The F-1000 can be mounted on horizontal or vertical runs of pipe. Mounting at the twelve o'clock position on horizontal pipe is recommended. Mounting anywhere around the diameter of vertical pipe is acceptable, however, the pipe must be completely full of water at all times. See figure 4, 5 and 6.
- Be sure the inlet and outlet plumbing is properly secured. The F-1000 is not designed to support the weight of related piping. Improperly supported pipes will put stress on the adapter connections and may cause leaking or fitting damage.

Nominal Pipe Size	Body Description	Length L	Height H
3/8"	3/8" MPT-low flow	4.73"	5.29"
3/8"	3/8" MPT-std flow	4.73"	5.38"
1/2"	1/2" MPT-low flow	5.09"	5.29"
1/2"	1/2" MPT-std flow	5.09"	5.38"
3/4"	3/4" MPT-low flow	5.25"	5.38"
3/4"	3/4" MPT-std flow	5.25"	5.57"
1.0"	1.0" MPT-low flow	5.65"	5.57"
1.0"	1.0" MPT-std flow	5.65"	5.57"
1.5"	1.5" MPT-std flow	6.50"	6.13"
2.0"	2.0" MPT-std flow	6.75"	6.38"

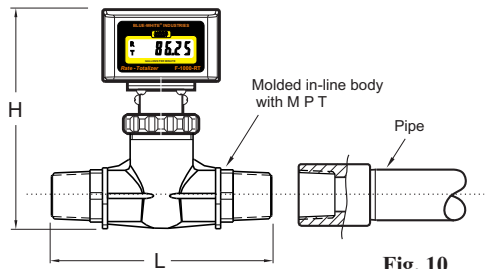

Fig. 10

4.5 HOW TO INSTALL MOLDED PVC TEE FITTINGS (TE)

- Select an area on the pipe as outlined in section 4.1.
- Remove the F-1000 sensor from the tee fitting. Do not glue the TEE while the sensor is installed.
- Install the F-1000 tee fitting as you would any other plastic pipe solvent weld (glue) fitting. Do not use too much glue. Excessive glue may create a disturbance in the flow stream which will effect the accuracy of the meter.
- The F-1000 can be mounted on horizontal or vertical runs of pipe. Mounting at the twelve o'clock position on horizontal pipe is recommended. Mounting anywhere around the diameter of vertical pipe is acceptable, however, the pipe must be completely full of water at all times. See figure 4, 5 and 6.
- Install the F-1000 sensor. Be sure two O-rings are located on the sensor body. The O-rings have been lubricated at the factory with silicone oil. Push the sensor assembly into the saddle on the saddle. The notch on the sensor body must fit into the slot on the saddle. Be sure the sensor is fully inserted into the saddle. **HAND TIGHTEN** the union nut.

Nominal Pipe Size	Length L	Height H
1"	4"	6"
1-1/2"	4-1/2"	6-5/8"
2"	4-3/4"	7-1/8"

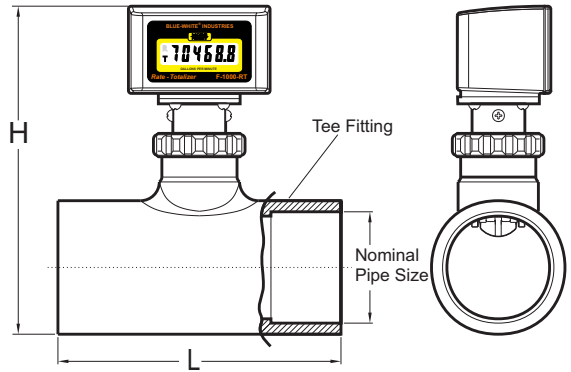
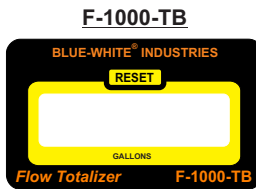
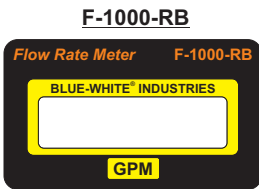

Fig. 11

5.0 HOW TO OPERATE THE F-1000

Note: The calibrated units of measure such as GPM, LPM, M3H, GALLONS, LITERS, CUBIC METERS, etc., And the decimal point location are preprogrammed at the factory to standard flow ranges (see chart). Any unit of measure can be factory programmed. Please contact the factory for details.

- The meter is shipped from the factory with 2 AAA batteries installed.
- When measuring continuous flow (i.e. 24 hours per day, 7 days per week), do not operate the meter in the upper 25% of the calibrated flow range. The paddle speed in these high flow ranges is fast. Damage to the paddle may occur if the meter is allowed to run continuously at the high flow rate, especially with corrosive or abrasive fluids.
- Model F-1000-RB:The F-1000-RB is the basic rate meter. The meter will display the rate of flow from .01 through 999999 in any engineering units. Some standard units of measure are GPM, GPH, GPD, LPM, LPH, LPD, M3H, etc.
- Model F-1000-TB:The F-1000-TB is the basic totalizer meter. The meter will display the total flow amounts from .01 through 999999 in any engineering units. Some standard units of measure are GALLONS, LITERS, CUBIC METERS. Pressing and holding the RESET button (located on the front panel) for at least 2.0 seconds resets the total to zero. This feature can be disabled -- see Fig. 12 below.
- Model F-1000-RT:The F-1000-RT is the rate and totalizer meter. The meter will display the flow rate amounts and the total flow amounts from .01 through 999999 in any engineering units. Some standard units of measure are GALLONS PER MINUTE, GALLONS PER HOUR, GALLONS PER DAY, LITERS PER MINUTE, LITERS PER HOUR, LITERS PER DAY, CUBIC METERS PER HOUR, CUBIC METERS PER DAY. Pressing the RESET button (located on the front panel) toggles the display between flow rate and total flow. Pressing and holding the RESET button for at least 2.0 seconds while the total flow value is displayed will reset the total to zero. This feature can be disabled. See Fig. 12 below.



F-1000 Circuit Board

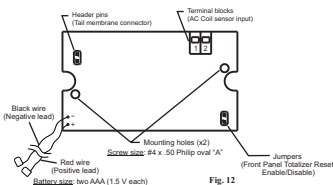

JUMPER CONFIGURATION	
Jumper Not Installed (open)	Jumper Installed
Total flow reset to zero Enable (Factory default)	Total flow reset to zero Disable

6.0 FLOW RANGES

- The F-1000 is factory calibrated to $\pm 2\%$ of full scale rate reading. When measuring total flow, accumulated error over time must be considered. Accuracy is based on laboratory testing of nominal pipe dimensions. Your actual accuracy will vary based on your actual pipe I.D. And other installation factors.
- Due to increased wear on the paddle and axle, continuous operation at the upper 25% of the flow range is not recommended.

METRIC PIPES

(Meet DIN 8062)

SADDLES - Standard Flow [Min - Max]

Pipe Size	LPM 1	LPH 1	M3H 1
50 MM - PN 10 & PN 16	70.0 - 700.0	4200 - 42000	4.20 - 42.00
63 MM - PN 10 & PN 16	110 - 1100	6600 - 66000	6.60 - 66.00
75 MM - PN 10 & PN 16	150-1500	9000 - 90000	9.00 - 90.00
90 MM - PN 10 & PN 16	230 - 2300	13800 - 138000	13.8 - 138.0
110 MM - PN 10 & PN 16	350 - 3500	21000 - 210000	21.0 - 210.0
160 MM - PN 10 & PN 16	720 - 7200	43000 - 430000	43.0 - 430.0
200 MM - PN 10 & PN 16	1150 - 11500	70000 - 700000	70.0 - 700.0
160 MM - PN 10	1700 - 17000	100000 - 1000000	100 - 1000
200 MM - PN 10	2700 - 27000	170000 - 1700000	170 - 1700

IPS PIPES (Some molded bodies are no longer sold, but are shown for reference only.)

MOLDED INLINE BODIES [Min - Max] (Meet ASTM-D-1785)

Pipe Size	RANGE#	GPM	GPH	GPD	LPM	LPH	M3H
3/8"	1	.800 - 8.000	48.0 - 480.0	1100 - 11000	3.00 - 30.00	180 - 1800	0.180 - 1.800
3/8"	2	.400 - 4.000	20.0 - 200.0	550 - 5500	1.00 - 10.00	60.0 - 600.0	0.060 - 0.600
1/2"	1	2.00 - 20.00	120 - 1200	2800 - 28000	7.00 - 70.00	420 - 4200	0.420 - 4.200
1/2"	2	.500 - 5.000	30.00 - 300.0	700 - 7000	2.00 - 20.00	120 - 1200	0.120 - 1.200
3/4"	1	3.00 - 30.00	180 - 1800	4320 - 43200	11.0 - 110.0	660 - 6600	0.660 - 6.600
3/4"	2	.800 - 8.000	48.0 - 480.0	1100 - 11000	3.00 - 30.00	180 - 1800	0.180 - 1.800
1"	1	5.00 - 50.00	300 - 3000	7200 - 72000	20.0 - 200.0	1200 - 12000	1.20 - 12.00
1"	2	2.00 - 20.00	120 - 1200	2800 - 28000	7.00 - 70.00	420 - 4200	0.420 - 4.200
1-1/2"	1	4.00 - 40.00	240 - 2400	5700 - 57000	15.0 - 150.0	900 - 9000	0.900 - 9.000
1-1/2"	2	6.00 - 60.00	360 - 3600	8600 - 86000	25.0 - 250.0	1500 - 15000	1.50 - 15.00
1-1/2"	3	10.0 - 100.0	600 - 6000	14400 - 144000	40.0 - 400.0	2400 - 24000	2.40 - 24.00
2"	1	4.00 - 40.00	240 - 2400	5700 - 57000	15.0 - 150.0	900 - 9000	0.900 - 9.000
2"	2	6.00 - 60.00	360 - 3600	8600 - 86000	25.0 - 250.0	1500 - 15000	1.50 - 15.00
2"	3	10.0 - 100.0	600 - 6000	14400 - 144000	40.0 - 400.0	2400 - 24000	2.40 - 24.00
2"	4	20.0 - 200.0	1200 - 12000	28800 - 288000	70.0 - 700.0	4200 - 42000	4.20 - 42.00

SADDLES - Standard Flow [Min - Max]

Pipe Size	GPM 1	GPH 1	GPD 1	LPM 1	LPH 1	M3H 1
1-1/2" IPS	15.0 - 150.0	900 - 9000	21500 - 215000	60.0 - 600.0	3600 - 36000	3.60 - 36.00
2.0" IPS	30.0 - 300.0	1800 - 18000	43000 - 430000	100 - 1000	6000 - 60000	6.00 - 60.00
2.5" IPS	40.0 - 400.0	2400 - 24000	57600 - 576000	150 - 1500	9000 - 90000	6.00 - 60.00
3.0" IPS	60.0 - 600.0	3600 - 36000	86500 - 865000	250 - 2500	15000 - 150000	15.0 - 150.0
4.0" IPS	100 - 1000	6000 - 60000	144000 - 999999	400 - 4000	24000 - 240000	24.0 - 240.0
6.0" IPS	250 - 2500	15000 - 150000	360000 - 999999	900 - 9000	54000 - 540000	54.0 - 540.0
8.0" IPS	400 - 4000	24000 - 240000	575000 - 999999	1500 - 15000	90000 - 900000	90.0 - 900.0
10.0" IPS	600 - 6000	36000 - 360000	865000 - 999999	2200 - 22000	132000 - 999999	132 - 1320
12.0" IPS	800 - 8000	48000 - 480000	N/A	3000 - 30000	180000 - 999999	180 - 1800

7.0 HOW TO MAINTAIN THE F-1000

The F-1000 requires very little maintenance, however, some conditions will cause increased wear on the paddle and/or possible damage to the unit. Damage caused by corrosive or abrasive fluids is not covered under warranty.

- Periodically remove the sensor assembly from the pipe fitting and inspect the meter for signs of wear and obstructions. Clean the paddle of any foreign objects. Paddle and axle wear can be caused by chemical attack and/or abrasive fluids. Replace the paddle and axle if worn. Various axle materials are available for corrosive fluids.
- Although the meter is capable of operating at the high end of the flow range, the meter should not be allowed to operate continuously at flow rates in the upper 1/4 or 25% of the calibrated flow range. The paddle and axle life is directly related to the rate of flow and the fluid being measured. Corrosive and abrasive fluids moving at high flow rates will cause increased wear requiring frequent inspection and maintenance. Ceramic, titanium or nickel axles are available for corrosive and abrasive fluids.
- Although the F-1000 is designed to withstand outdoor conditions, a cool, dry location where the unit can be easily serviced is recommended. The life of the LCD display will be severely reduced when installed in direct sunlight. Do not install the meter so that the LCD is in direct sunlight.
- O-rings should be inspected periodically. Immediately replace the o-rings at any sign of wear, swelling, cracking or discoloration.
- The meter is designed to withstand minor condensation inside the enclosure. Prolonged excessive moisture inside the enclosure, due to high humidity conditions, may damage the meter. Reduce the humidity or move the meter to a less humid location.
- Replace the two AAA batteries every 12 months. The program memory is “non-volatile” and will not erase when replacing the batteries. Processing power will be maintained for about 45 seconds, preventing the loss of totalizing data, while the batteries are being replaced. To replace the batteries, open the rear panel of the enclosure by removing the two Phillips screws. After replacing the batteries, be sure the foam insert is in place and the panel gasket seal is in good condition, before closing the rear panel.
- Test the electronics by removing the sensor assembly from the pipe fitting and spinning the paddle by hand. While spinning, the number “0” reading in the display window indicates that the battery is supplying power to the meter but a signal is not being processed by the circuitry. In this case, the circuitry must be serviced by an authorized service center.

8.0 TROUBLESHOOTING

Situation: *Leaking*

- Cause:** *Improper installation***Solution:** *Page 8, section 4.3*
Page 9, section 4.3.1 thru 4.3.4
Page 10, section 4.4, 4.5
- Worn or damaged O-rings*.....**Solution:** *Page 14, section 7.0*

Situation: *Moisture inside enclosure*

- Cause:** *Condensation***Solution:** *Page 14, section 7.0*
- Damaged panel gasket***Solution:** *Page 14, section 7.0*

Situation: *Flow rate reading is inaccurate*

- Cause:** *Improper installation*.....**Solution:** *Page 8, section 4.3*
- Improper velocity profile*.....**Solution:** *Page 5, section 4.1, 4.2*
- Improper alignment / installation*.....**Solution:** *Page 9, section 4.3.3*
- Worn paddle and/or axle*.....**Solution:** *Page 14, section 7.0*
- Accumulated reading error*.....**Solution:** *Page 13, section 6.0*

Situation: *No display*

- Cause:** *Electronics damaged*.....**Solution:** *Page 14, section 7.0*
- Dead batteries*.....**Solution:** *Page 14, section 7.0*

Situation: *Display shows zero flow*

- Cause:** *Saddle not aligned*.....**Solution:** *Page 9, section 4.3.3*
- Electronics damaged*.....**Solution:** *Page 14, section 7.0*
- Flow rate is out of range*.....**Solution:** *Page 13, section 6.0*

Paddle Removal

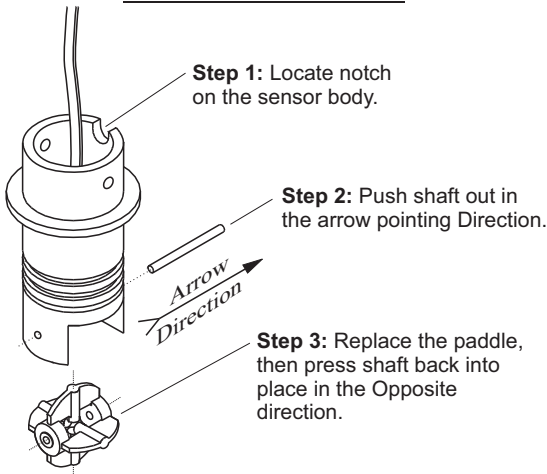
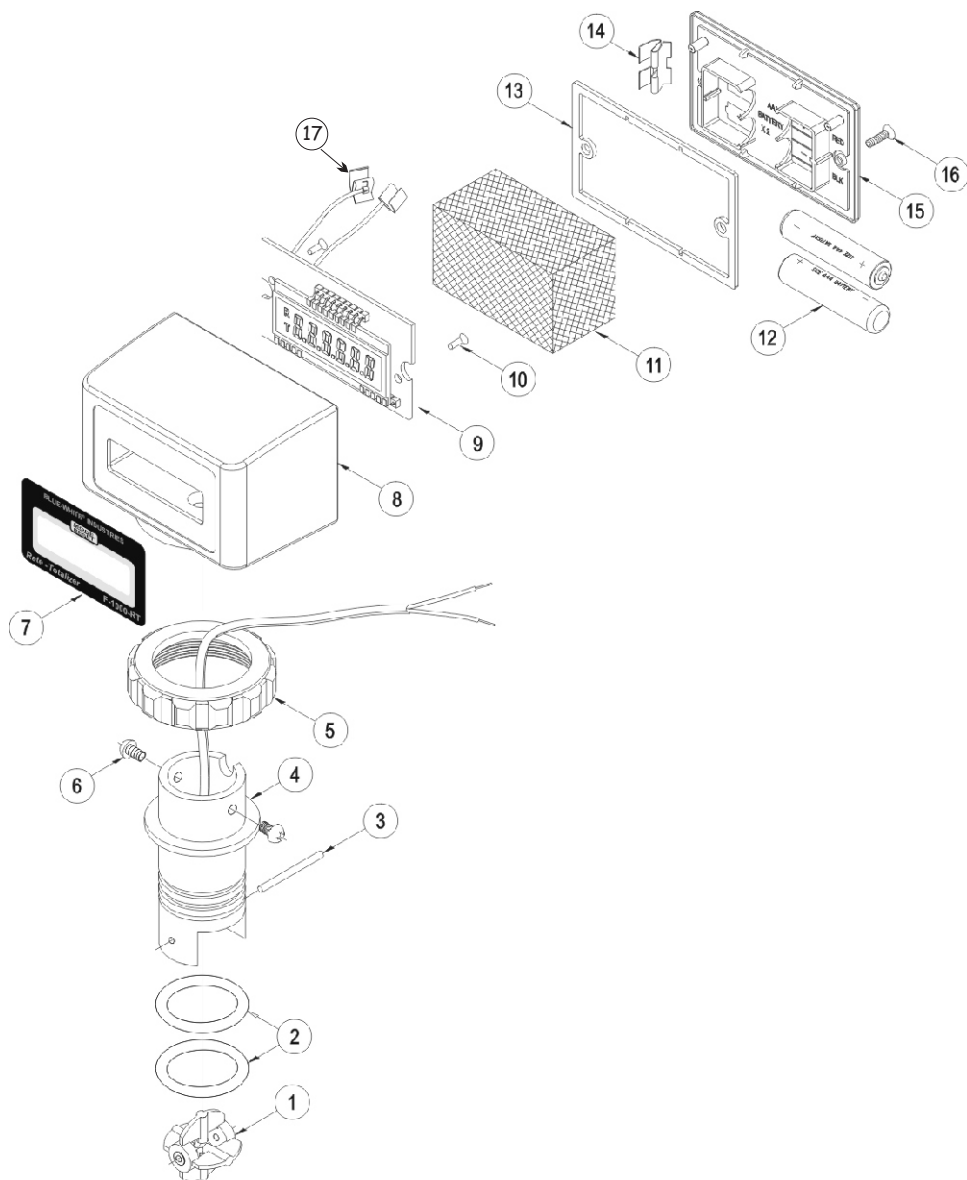

Fig. 13

9.0 F-1000 PARTS LIST



Item	Part#	Description	Qty
1	70000-783	Paddle assembly PVDF	1
2	90003-021	O-ring 022 Viton E60	2
3	90007-589	Axle PVDF	1
	90007-567	Axle Hastelly	1
4	71000-238	Sensor body assembly F-100 no paddle	1
5	91001-280	Union Nut	1
6	90011-080	Screw #6 x .37 PH Pan B 18/8	2
7	90012-198	Label F-1000-RB GPM	1
	90012-199	Label F-1000-RB GPH	1
	90012-200	Label F-1000-RB LPM	1
	90012-201	Label F-1000-RB LPH	1
	90012-202	Label F-1000-RB M ³ H	1
	90012-221	Label F-1000-TB overlay	1
	90012-222	Label F-1000-RT overlay	1
8	76001-187	Housing F-1000	1
9	RBC-pipe-units	Circuit board for model RB. Must specify pipe	1
	TBC-pipe-units	Circuit board for model TB. Must specify pipe	1
	RTC-pipe-units	Circuit board for model RT. Must specify pipe	1
10	90011-169	Screw #4 .25 Phil Pan "A"	1
11	90013-260	Foam pad 1.25 x 1.25 x 2.25	1
12	90008-318	Battery each AAA	2
13	90006-590	Gasket F-1000	1
14	90008-319	Battery clip F-1000	1
15	90002-203	Rear plate F-1000	1
16	90011-113	Screw #4 .50 Phil oval "A"	2
17	90010-241	Battery Connector	1

MOLDED IN-LINE BODY PARTS LIST

Complete Kit Ordering Numbers

Complete kits include:

- 1) Molded inline body fitting
- 1) Instruction manual

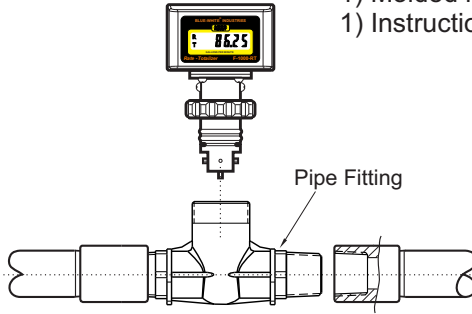

Molded In-Line Pipe Fittings

Pipe Size M/NPT	GPM Flow Range	LPM Flow Range	M ³ /HR Flow Range	OZ/Min Flow Range	Model Number	
					MNPT	MBSPT
3/8"	.8 to 8	30 - 30	0.2 - 1.8	106 - 1058	38M1	38MB1
3/8"	.4 to 4	1 - 10	0.1 - 0.6	35 - 353	38M2	38MB2
1/2"	2 to 20	7 - 70	0.4 - 4.2	247 - 2469	50M1	50MB1
3/4"	3 -30	11 - 110	0.7 - 6.6	388 - 3880	75M1	75MB1
1"	5 to 50	20 - 200	1.2 - 12	705 - 7054	10M1	10MB1
1-1/2"	6 to 60	25 - 250	1.5 - 15	885 - 8818	15M2	15MB2
2"	10 to 100	40 - 400	2.4 - 24	1411 - 14108	20M3	20MB3
2"	20 to 200	70 - 700	4.2 - 42	2469 - 24689	20M4	20MB4

TEE Pipe Fittings

Pipe Size	GPM Range	LPM Range	Model Number
			Solvent Weld PVC Tee
1"	6 to 60	25 - 250	10AT
1-1/2"	15 to 150	60 - 600	15AT
2"	30 to 300	100 - 1000	20AT
3"	60 to 600	230 - 2300	30AT

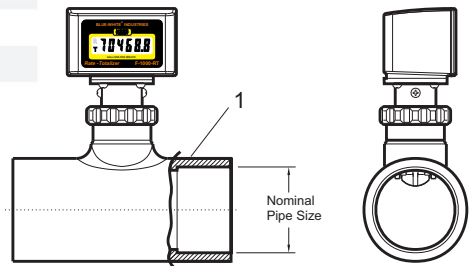

SADDLE PARTS LIST

Replacement Part Numbers

Item	Part No.	Description
1	90007-830	Alignment tool
2	91001-115	Saddle, 1-1/2" pipe (50mm)
	91001-114	Saddle, 2" pipe (63mm)
	91001-116	Saddle, 3" pipe (90mm)
	76100-087	Saddle, 4" pipe (110mm)
	76100-088	Saddle, 6" pipe (160mm)
	76100-089	Saddle, 8" pipe (200mm)
	76100-139	Saddle, 10" & 12" pipe
3	90008-010	Hose-Clamp #28 for 1-1/2" pipe
	90008-137	Hose-Clamp #40 for 2" pipe
	90008-015	Hose-Clamp #52 for 3" pipe
	90008-018	Hose-Clamp #72 for 4" pipe
	90008-019	Hose-Clamp #116 for 6" pipe
	90008-020	Hose-Clamp #152 for 8" pipe
	90008-348	Hose-Clamp #188 for 10" pipe
90008-349	Hose-Clamp #224 for 12" pipe	
4	90003-108	O-ring / Viton® for 1-1/2", 2", 3"
	90003-114	O-ring / Viton® for 4", 6", 8", 10", 12"

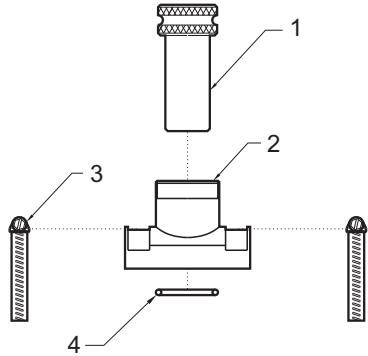

Complete Kit Ordering Numbers

U.S. (IPS) Pipe Saddle Fittings	
Kit No	Description
15K4	1-1/2" IPS pipe, schedule 40, PVDF
15K8	1-1/2" IPS pipe, schedule 80, PVDF
20K4	2" IPS pipe, schedule 40, PVDF
20K8	2" IPS pipe, schedule 80, PVDF
30K4	3" IPS pipe, schedule 40, PVDF
30K8	3" IPS pipe, schedule 80, PVDF
40A4	4" IPS pipe, schedule 40, PVC
40A8	4" IPS pipe, schedule 80, PVC
60A4	6" IPS pipe, schedule 40, PVC
60A8	6" IPS pipe, schedule 80, PVC
80A4	8" IPS pipe, schedule 40, PVC
80A8	8" IPS pipe, schedule 80, PVC
100A4	10" IPS pipe, schedule 40, PVC
100A8	10" IPS pipe, schedule 80, PVC
120A4	12" IPS pipe, schedule 40, PVC
120A8	12" IPS pipe, schedule 80, PVC

Metric (DIN 8062) Pipe Saddle Fittings	
Kit No	Description
05K0	50mm Metric pipe, Pn10, PVDF
05K6	50mm Metric pipe, Pn16, PVDF
06K0	63mm Metric pipe, Pn10, PVDF
06K6	63mm Metric pipe, Pn16, PVDF
09K0	90mm Metric pipe, Pn10, PVDF
09K6	90mm Metric pipe, Pn16, PVDF
11A0	110mm Metric pipe, Pn10, PVC
11A6	110mm Metric pipe, Pn16, PVC
16A0	160mm Metric pipe, Pn10, PVC
16A6	160mm Metric pipe, Pn16, PVC
20A0	200mm Metric pipe, Pn10, PVC

Complete kits include:

- 1) Saddle fitting
- 2) Pipe clamps
- 3) O-ring seal
- 1) Installation alignment tool
- 1) Instruction manual
- 1) Union nut

BLUE-WHITE LIMITED WARRANTY

Your Blue-White product is a quality product and is warranted for a specific time from date of purchase (proof of purchase is required). The product will be repaired or replaced at our discretion. Failure must have occurred due to defect in material or workmanship and not as a result of operation of the product other than in normal operation as defined in the product manual. Warranty status is determined by the product's serial label and the sales invoice or receipt. The serial label must be on the product and legible. The warranty status of the product will be verified by Blue-White or a factory authorized service center.

Variable Area and Digital Flow meters are warranted for 1 year from date of purchase (proof of purchase is required). The flow meter will be repaired or replaced at our discretion. The S6A ultrasonic flow meter is warranted for 2 years from date of purchase (proof of purchase is required). The flow meter will be repaired or replaced at our discretion.

WHAT IS NOT COVERED

- Freight to the factory, or service center.
- Products that have been tampered with, or in pieces.
- Damage resulting from misuse, carelessness such as chemical spills on the enclosure, abuse, lack of maintenance, or alteration which is out of our control.
- Damage by faulty wiring, power surges or acts of nature.
- Damage that occurs as a result of: meter misalignment, improper installation, over tightening, use of non-recommended chemicals, use of non-recommended adhesives or pipe dopes, excessive heat or pressure, or allowing the meter to support the weight of related piping.

BLUE-WHITE does not assume responsibility for any loss, damage, or expense directly or indirectly related to or arising out of the use of its products. Failure must have occurred due to defect in material or workmanship and not as a result of operation of the product other than in normal operation as defined in the manual.

Warranty status is determined by the product's serial label and the sales invoice or receipt. The serial label must be on the product and legible. The warranty status will be verified by Blue-White or a factory authorized service center.

PROCEDURE FOR IN WARRANTY REPAIR

Warranty service must be performed by the factory or an authorized service center. Contact the factory or local repair center to obtain a RMA (Return Material Authorization) number. It is recommended to include foot strainer and injection/check valve fitting since these devices may be clogged and part of the problem. Decantamine, dry, and carefully pack the product to be repaired. Please enclose a brief description of the problem and proof of purchase. Prepay all shipping and insurance cost. COD shipments will not be accepted. Damage caused by improper packaging is the responsibility of the sender. When In-Warranty repair is completed, the factory pays for return shipping to the dealer or customer.

PRODUCT USE WARNING

Blue-White products are manufactured to meet the highest quality standards in the industry. Each product instruction manual includes a description of the associated product warranty and provides the user with important safety information. Purchasers, installers, and operators of Blue-White products should take the time to inform themselves about the safe operation of these products. In addition, Customers are expected to do their own due diligence regarding which products and materials are best suited for their intended applications. BLUE-WHITE is pleased to assist in this effort but does not guarantee the suitability of any particular product for any specific application as Blue-White does not have the same degree of familiarity with the application that the customer/end user has. While BLUE-WHITE will honor all of its product warranties according to their terms and conditions, Blue-White shall only be obligated to repair or replace its defective parts or products in accordance with the associated product warranties.

BLUE-WHITE SHALL NOT BE LIABLE EITHER IN TORT OR IN CONTRACT FOR ANY LOSS OR DAMAGE WHETHER DIRECT, INDIRECT, INCIDENTAL, OR CONSEQUENTIAL, ARISING OUT OF OR RELATED TO THE FAILURE OF ANY OF ITS PARTS OR PRODUCTS OR OF THEIR UNSUITABILITY FOR A GIVEN PURPOSE OR APPLICATION.

CHEMICAL RESISTANCE WARNING

BLUE-WHITE offers a wide variety of wetted parts. Purchasers, installers, and operators of Blue-White products must be well informed and aware of the precautions to be taken when injecting or measuring various chemicals, especially those considered to be irritants, contaminants or hazardous. Customers are expected to do their own due diligence regarding which products and materials are best suited for their applications, particularly as it may relate to the potential effects of certain chemicals on Blue-White products and the potential for adverse chemical interactions. Blue-White tests its products with water only. The chemical resistance information included in this instruction manual was supplied to BLUE-WHITE by reputable sources, but Blue-White is not able to vouch for the accuracy or completeness thereof. While BLUE-WHITE will honor all of its product warranties according to their terms and conditions, Blue-White shall only be obligated to repair or replace its defective parts or products in accordance with the associated product warranties.

BLUE-WHITE SHALL NOT BE LIABLE EITHER IN TORT OR IN CONTRACT FOR ANY LOSS OR DAMAGE, WHETHER DIRECT, INDIRECT, INCIDENTAL, OR CONSEQUENTIAL, ARISING OUT OF OR RELATED TO THE USE OF CHEMICALS IN CONNECTION WITH ANY BLUE-WHITE PRODUCTS.

Users of electrical and electronic equipment (EEE) with the WEEE marking per Annex IV of the WEEE Directive must not dispose of end of life EEE as unsorted municipal waste, but use the collection framework available to them for the return, recycle, recovery of WEEE and minimize any potential effects of EEE on the environment and human health due to the presence of hazardous substances. The WEEE marking applies only to countries within the European Union (EU) and Norway. Appliances are labeled in accordance with European Directive 2002/96/EC. Contact your local waste recovery agency for a Designated Collection Facility in your area.



URL: www.Blue-White.com
E-mail: sales@blue-white.com
Customerservice@blue-white.com

Phone: 714-893-8529
Fax: 714-894-0149