

EchoPro LR36

Pulse Radar Solids Level Transmitter



Application

The intrinsically safe 26 GHz. pulse radar transmitter provides continuous level measurement up to 49.2' (15m) with a 4-20 mA analog and HART digital signal output, and is configured via its integral push button display module or HART communicator. The non-contact solids level sensor is intended for dry solid media including aggregates, grains, pellets, powders and building materials. Select this sensor for **easy process conditions with minimal dust** and installation with an adjustable mounting bracket or gimbal flange. Typical applications include bins, transfer stations and crushers.



Features

- Rugged 316L stainless steel antenna and process mount
- Configuration via push button display or HART communicator
- Gimbal flange for easy positioning with the angle of repose
- LCD displays level in feet or meters with percent of span bar
- Optional display mode indicates the echo signal return curve
- Fail-safe diagnostics with selectable signal fail-safe outputs
- Recognition, storage and rejection of false echo signal returns
- IP67 stainless enclosure with polycarbonate display window

Mounting Bracket

The LR97-S006 mounting bracket allows you to easily install and adjust the sensor angle for optimum placement relative to the materials angle of repose in installations without an enclosed top. Constructed of 304 stainless steel, the rugged bracket is widely used in crusher, transfer station, stockpile or open top bin applications.



LR36-5021-40-00
Shown



Push Button
Display Module

EchoPro LR36

Pulse Radar Solids Level Transmitter



Specifications

Range:	12" to 49.2' (30cm to 15m)
Frequency:	26 GHz.
Accuracy	± 10mm
Dead band:	12" (30cm)
Beam angle:	8°
Configuration:	Push button, HART 7
Memory:	Non-volatile
Display type:	LCD, dot matrix
Display units:	Feet and meters
Display bar:	Percent of span
Display graph:	Echo signal curve
Supply voltage:	21.6 to 26.4 VDC
Max. consumption:	22.5 mA
Signal output:	4-20 mA, two-wire, HART 7
Signal invert:	4-20 mA, 20-4 mA
Signal fail-safe:	3.9 mA, 20.5 mA, 22 mA
Process temp.:	F: -40° to 392° C: -40° to 200°
Temp. comp.:	Automatic
Storage temp.:	F: -40° to 176° C: -40° to 80°
Pressure:	-40: -14.5 to 580 psi (-1 to 40 bar) -44 & -45: Atmospheric
Enclosure rating:	IP67
Encl. material:	316L stainless steel w/silicone gasket
Encl. window mat.:	Polycarbonate
Conduit entrance:	(1) 1/2" NPT connector
Antenna material:	316L
Process mount:	-40: 1 1/2" NPT -44: 4" gimbale flange (ANSI)
Classification:	Intrinsically safe
Approvals:	ATEX Ⓔ IIG Ex ia II C T6...T3 Ga IEC Ex ia IIC T6...T3 Ga CSA Class I, Div 1, Groups A, B, C & D; Class II, Div 1, Groups E, F & G; (T6...T3); Class I Zone 0 AEx ia IIC (T6...T3) Ga & Zone 20 AEx ia IIC (T76°C to T146°C) Da; Ex ia IIC (T6...T3) Ga & Ex ia IIC (T76°C to T146°C) Ga
Certification:	FCC
Compliance:	CE, RoHS

Dimensions

FLANGE

P/N	-44
A	4" ANSI
B	9.0" (228.6mm)
C	0.4" (10.2mm)

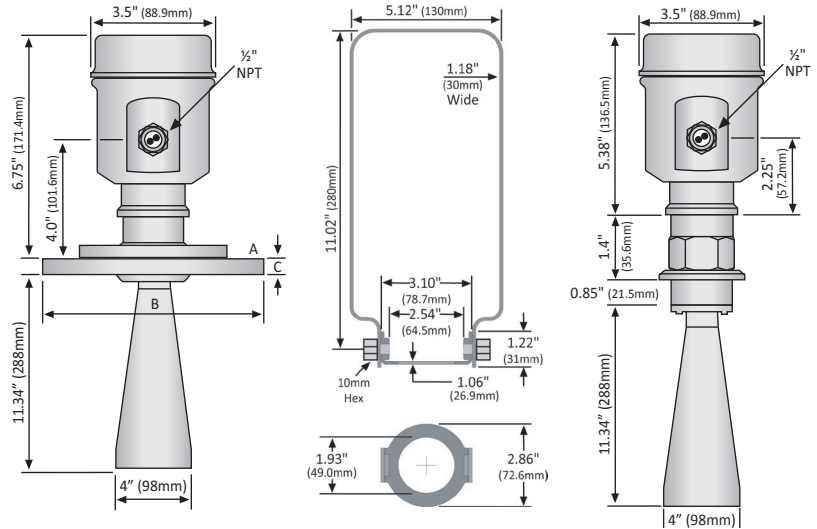

Level Indicator



LI24-1001

DATALOOP™

Intrinsically Safe Level Indicator

UL approved intrinsically safe, the loop powered level indicator displays engineering units connected in series with one 4-20 mA level transmitter. Select the LI24-1001 level indicator for hazardous applications with an intrinsically safe sensor. For field mount installation, add a single or two indicator NEMA box.

Ordering

LR36-5 21-4 -00

MOUNT TYPE (1) (2)

- 0 NPT thread
- 3 ANSI flange

MOUNT SIZE (3)

- 0 1 1/2" NPT
- 4 4" gimbale flange

NOTES

- 1) If you want help in selecting a sensor for your application, please go to our website and submit a Level Questionnaire. An engineer will review your requirements and suggest a product solution via email.
- 2) For bracket mount installations, order the 0 mount type, 0 mount size and purchase a LR97-S006 mounting bracket.
- 3) The 0 mount size is compatible with the 0 mount type. The 4 mount sizes are compatible with the 3 mount type.