



Lutz horizontal eccentric screw pumps B70H Series

For mobile and stationary application

NEW



Safety is our concern

Lutz eccentric screw pumps

B70H Series

The H stands for horizontal!

The B70H is a variation of our B70V and is designed for the horizontal use on a trolley. It can be used in situations where the B70V comes across space limits or limits of handling and thus completes our range of eccentric screw pumps with a mobile version.

Features/Benefits

- » By positioning outside of the container, it is possible to pump liquid out of the stacked containers - or containers which are not accessible from the top
- » Due to the compact construction height, emptying at limited room height is possible
- » Easy handling of heavy pumps
- » No physical strain due to lifting
- » Easy replacement of wearing parts by the new rotor/stator combination
- » On request a fluid transfer is possible in either direction of rotation
- » By replacing the rotor/stator unit, an easy change of size is possible
- » Also available in PURE and explosion-proof design
- » Mobility by a trolley

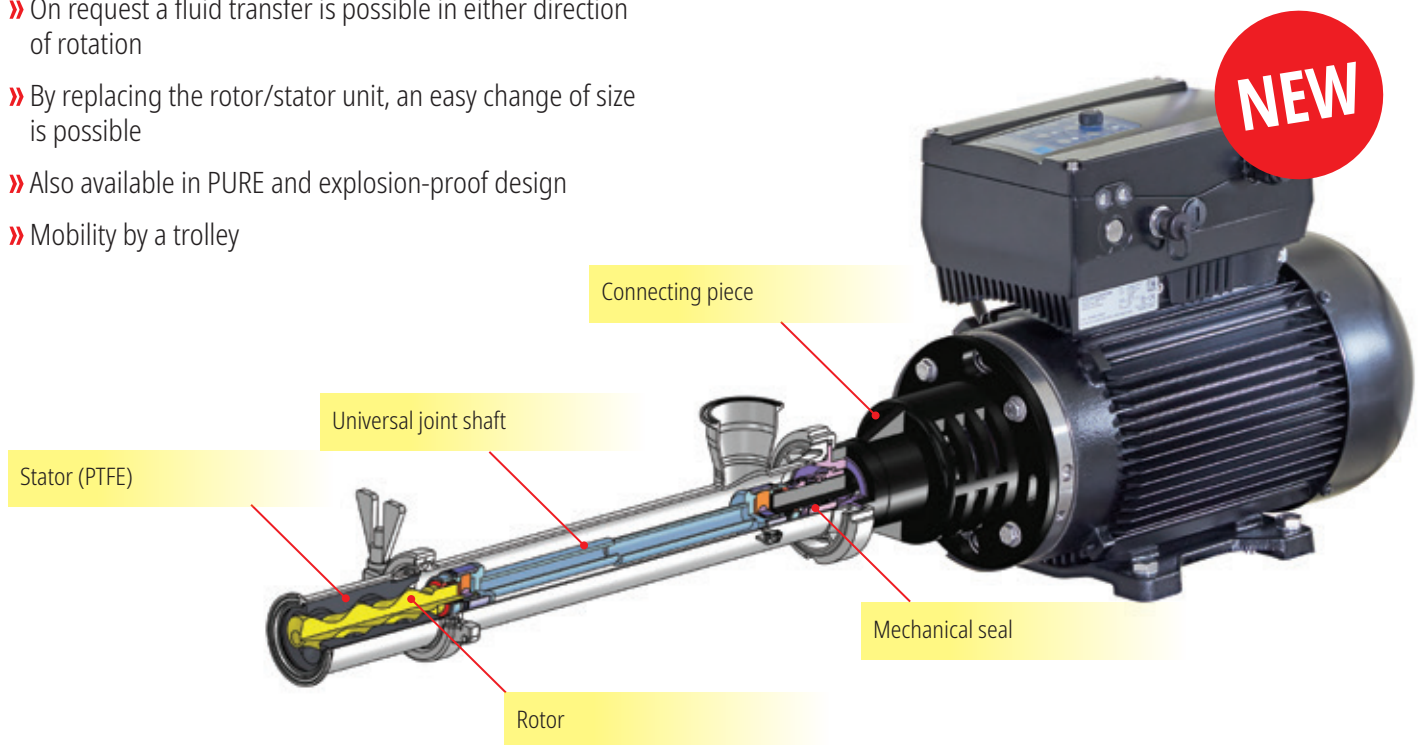

Optional with stainless steel trolley with normal or conductive wheels. In conjunction with a flow meter and operating unit, a mobile filling station is created.

Easy change of size

- Changing between different stator materials is possible with the same stator sleeve.
- A conversion from 25.1 to 75.1 is possible by replacing the stator sleeve.
- The pump tube and shaft are always the same length and compatible with each rotor/stator unit.
- By replacing stator, rotor and stator sleeve, a conversion to any rotor/stator combination is possible.

Liquid examples

Lutz horizontal eccentric screw pumps are suitable for pumping aqueous to highly viscous Newtonian and non-Newtonian media. The pumps are suitable for abrasive, solids containing and shear sensitive media, as well as for neutral, aggressive and easy flammable liquids under high delivery pressure.



Lutz eccentric screw pumps

B70H 25.1 and 75.1

Productdetail	Pump tube		B70H		
	Size		25.1	75.1	
	Seal	Mechanical seal (MS)	MS	MS	
	Drive shaft	Universal joint shaft (UJ)	UJ	UJ	
	Flow rate*	up to l/min.	25	75	
	Delivery head*	up to bar	8	8	
	Temperature of medium**	max. °C	140	140	
	Material outer tube		1.4571/1.4404	1.4571/1.4404	
	Pressure joint	Tri-Clamp	DN 50	DN 50	
	Weight	kg	5.5	6.5	
	Length	mm	400	500	
	Stator PTFE (T max. 140 °C)	Order no.	0176-401	0176-404	
	<p>* Determined with water at 20 °C, three-phase motor (900 1/min) and elastomer stator</p> <p>** With stator PTFE (for explosion-proof eccentric screw pumps B70H, the temperature of the pumped medium must not exceed 100 °C)</p> <p>● Explosion-proof eccentric screw pump approved category 2 (according to ATEX) for pumping flammable liquids of the explosion group IIA and IIB. Temperature class T4 at 40°C ambient temperature or temperature class T3 at 60°C ambient temperature. Please note: Mechanical seal which is independent from rotating direction on request</p>				
	Motor selection				
Motors with cable terminal box					
	Version	1.5 kW, 900 1/min.			
	Protection type/weight	IP 55, 32 kg			
	Order No.	0176-803			
	Motors with protection switch				
Version	1.5 kW, 900 1/min.				
Protection type/weight	IP 55, 32 kg				
Order No.	0176-806				
Motor, explosion-proof					
Version	0.95 kW, 900 1/min.				
Marking	II 2 G Ex e II T3				
Protection type/weight	IP 55, 21 kg				
Order No.	0176-805				
Motors with frequency converter					
Version	1.5 kW, 0-900 1/min.				
Protection type/weight	IP 55, 35 kg				
Order No.	0176-804				
<p>Three-phase 230/400 V, 50 Hz, energy efficiency category IE 3 in accordance with EU Regulations 640/2009 and 04/2014. Special tension, frequency, protection types as well as increased ex-protection classes on request.</p>					

B70H 25.1 and 75.1

For viscosities of 100.000 mPas

Materials (coming into contact with the pumped medium):

Version:	B70H 25.1	B70H 75.1
Housing:	Stainless steel (1.4571/1.4404)	Stainless steel (1.4571/1.4404)
Rotor:	Stainless steel (1.4571)	Stainless steel (1.4571)
Seals*:	FPM	FPM
Mechanical seal*:	Carbon/CrMo-casting, FPM	Carbon/CrMo-casting, FPM
Drive shaft:	Stainless steel (1.4571)	Stainless steel (1.4571)
Stator materials:	PTFE	PTFE

Other sealing materials on request



Pump tube with stator in PTFE is also available in PURE version. Special application in the food and cosmetics industry as well as in the pharmaceuticals.

Important info

Range of viscosity aqueous up to flowability limit.

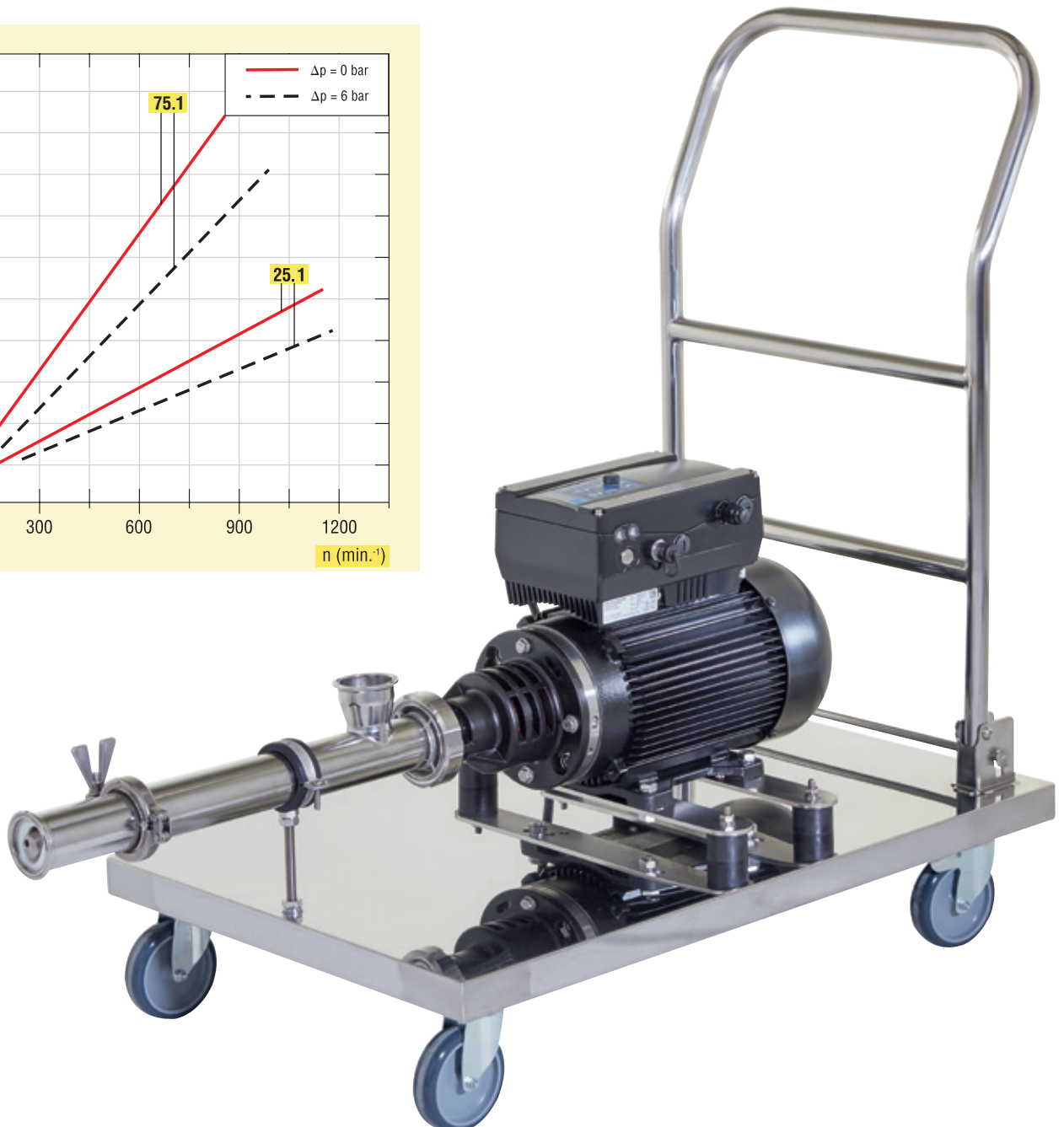
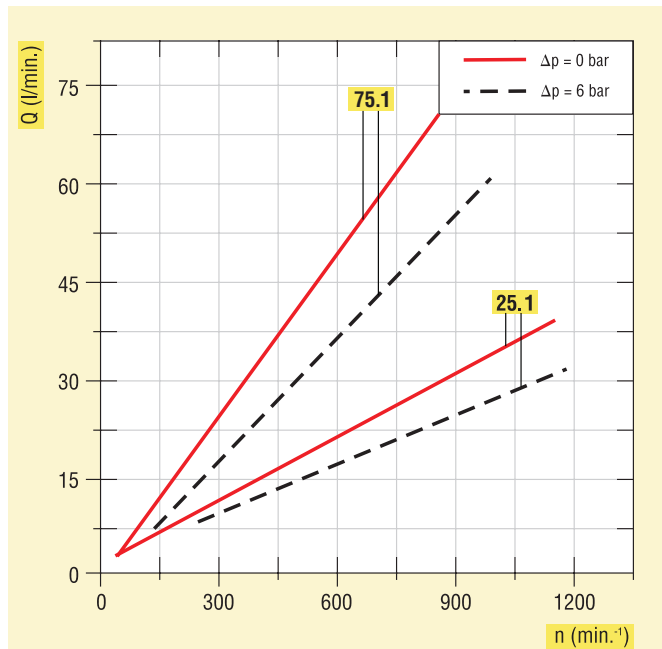

Liquid table with examples of liquids see resistance table.



Accessories

Product detail	Specification	Order No.
	<p>Trolley for horizontal eccentric screw pump B70H For mobile use of B70. With fixing material to assemble the motor.</p> <p>Material: Stainless steel (1.4571) Dimensions trolley 820 x 520 x 940 mm</p> <p>Trolley</p> <p>Trolley with electrically conductive wheels</p> <p>Additional price trolley for ex motor protection switch (Order motor protection switch separately)</p>	<p>0208-194</p> <p>0208-195 ●</p> <p>0208-198 ●</p>
	<p>Motor protective switch for motor B70H Explosion proof according to EEx de IIC T6 with thermal and electromagnetic trip, protection type IP 66.</p> <p>Ex, 2.5 - 4.0 A for B70H (Ex)</p>	<p>0335-419 ●</p>
	<p>PVC spiral hose, fabric reinforced Hose for food liquids made of PVC, with woven layer and imbedded galvanized steel helix, inside and outside smooth, complies with EU-regulations 10/2011 and 1935/2004.</p> <p>Operating pressure: max. 14 bar Temperature of liquid: -5 up to +65 °C Nominal diameter: Weight: DN 38 (1 1/2") 1.15 kg/m DN 50 (2") 1.60 kg/m</p>	<p>0374-469</p> <p>0374-470</p>
	<p>Universal chemical hose Colour coding: "blue/white/blue". Suitable for food and luxury foodstuffs, pharmaceuticals, cosmetics and hygiene products Conform to FDA and USP class VI. Complies with EU-regulations 10/2011 and 1935/2004. Internal finish: UPE light with spiraled OHM conductive stripes UPE black, smooth, non-bleeding, abrasion-resistant. Intermediate layer: EPDM conductive complies with the requirements of the recommendation XXI category 2 of the BfR and FDA standards. External finish: EPDM light grey, conductive, non-bleeding, ozone- and UV resistant, hardly flammable, (starting from DN 25 with galvanized steel helix, suitable as suction and pressure hose). Electrically conductive: Type Ω/T (<10⁶ Ohm between the fittings, <10⁹ Ohm through the hose wall) according to DIN EN 12115:2011.</p> <p>Operating pressure: max. 16 bar Temperature of liquid: -30 up to +100 °C (dependant on the liquid), can be sterilized at 130°C for 30 minutes (open system)</p> <p>Nominal diameter: Weight: DN 38 (1 1/2") 1.2 kg/m DN 50 (2") 1.9 kg/m</p>	<p>0374-478 ●</p> <p>0374-479 ●</p>

● Suitable for transferring flammable and easy flammable liquids (e.g. Ethanol, petrol) or in explosive hazard area.

Specification	Order No.	Product detail									
<p>Hose clips</p> <p>Stainless steel hose clips with threaded screw for fixing hoses of various nominal bore at the hose connection.</p> <p>Nominal diameter: DN 32 - 38 (1 1/4" - 1 1/2") DN 50 (2")</p>	<p>0302-402 0302-403</p>										
<p>Hose connection with Tri-clamp</p> <p>For connecting the hose to the eccentric screw pump B70, discharge spout or Tri-Clamp armatures (comprising a hose connection, locking clamp and seal)</p> <p>Material: Stainless steel (1.4404)</p> <table border="0"> <tr> <td>Connection:</td> <td>for hose nominal diameter:</td> <td>Seal:</td> </tr> <tr> <td>Tri-Clamp DN 50</td> <td>DN 38 (1 1/2")</td> <td>FPM</td> </tr> <tr> <td>Tri-Clamp DN 50</td> <td>DN 50 (2")</td> <td>FPM</td> </tr> </table> <p>Please note: The assembler is responsible for the professional fixing of the hose according to the current Pressure Equipment Directive.</p>	Connection:	for hose nominal diameter:	Seal:	Tri-Clamp DN 50	DN 38 (1 1/2")	FPM	Tri-Clamp DN 50	DN 50 (2")	FPM	<p>0204-878 0204-880</p>	
Connection:	for hose nominal diameter:	Seal:									
Tri-Clamp DN 50	DN 38 (1 1/2")	FPM									
Tri-Clamp DN 50	DN 50 (2")	FPM									
<p>Hose connector with Tri-clamp</p> <p>For connection of conductive hose onto the eccentric screw pump B70, discharge spout or Tri-Clamp armatures in explosive hazardous area. The hose connector ensures a highly conduction transition between conductive hose and pump/armature.</p> <p>The ohmic resistance between the armatures must be lower than 10⁶ Ohm. (Consisting of hose connector, clamp collars, locking clamp and seal)</p> <p>Material: Stainless steel (1.4404)</p> <table border="0"> <tr> <td>Connection:</td> <td>for hose Nominal diameter:</td> <td>Seal:</td> </tr> <tr> <td>Tri-Clamp DN 50</td> <td>DN 50 (2")</td> <td>FPM</td> </tr> </table>	Connection:	for hose Nominal diameter:	Seal:	Tri-Clamp DN 50	DN 50 (2")	FPM	<p>0204-869 ●</p>				
Connection:	for hose Nominal diameter:	Seal:									
Tri-Clamp DN 50	DN 50 (2")	FPM									

Further accessories can be found in our eccentric screw pump leaflet or on request.





Lutz Pumpen GmbH

Erlenstraße 5-7
D-97877 Wertheim
Phone: +49 93 42 / 8 79-0
Fax: +49 93 42 / 87 94 04
E-Mail: info@lutz-pumpen.de

www.lutz-pumpen.de